



79 Elm Street • Hartford, CT 06106-5127

www.ct.gov/deep

Affirmative Action/Equal Opportunity Employer

Date: August 18, 2021

John Henshaw, Executive Director
Connecticut Port Authority
455 Boston post Road, Suite 204
Old Saybrook, CT 06475

SUBJECT: License #201905859-SDF TW WQC
200 State Pier Road, New London

Dear Mr. Henshaw:

Please find attached a copy of your reissued subject license and relevant enclosures in response to your application. The Department of Energy & Environmental Protection has reissued the permit with today's date to include the appropriate attachments. This reissued permit replaces the permit dated August 13, 2021, because two documents that should have been attached to the August 13th permit were inadvertently omitted. In addition, the signed plans will be utilized in lieu of the unsigned plans. Your attention is directed to the conditions of the license. All work must conform to that which is specifically authorized.

Any work in regulated areas of the State which has not been authorized by a valid license is a violation of state law and subject to enforcement action by the Department of Energy & Environmental Protection and the Office of the Attorney General.

Your initiation of authorized activities will be relied upon as your agreement to comply with the terms and conditions of the license.

If you have not already done so, you should contact your local Planning and Zoning Office and the U. S. Army Corps of Engineers to determine local and federal permit requirements on your project, if any. Write the Corps' New England District, Regulatory Branch, 696 Virginia Road, Concord, MA 01742-2751; <http://www.nae.usace.army.mil/> or call 1-800-343-4789.

If you have any questions concerning your permit, please contact me at 860-424-3674 or micheal.grzywinski@ct.gov.

Sincerely,

A handwritten signature in blue ink, appearing to read "M.P. Grzywinski", followed by a horizontal line extending to the right.

Micheal Grzywinski, Environmental Analyst III
Land & Water Resources Division
Bureau of Water Protection & Land Reuse

Enc. – License #201905859 (original cover letter, License, LWRD Dredging and General Conditions, Land Record Filing, LWRD Dredging Reporting Form, Work Commencement Form, Compliance Certificate Form, Plan Set)

cc: File #201905859 (original license; copy cover letter, LWRD Dredging and General Conditions, Land Record Filing, LWRD Dredging Reporting Form, Work Commencement Form, Compliance Certificate Form, Plan Set)

Certified to: Owners of franchised oyster ground/lessee of leased oyster ground;

First Class to: Adjacent Property Owners;

E-mail to:

John Henshaw, CT Port Authority, jhenshaw@ctportauthority.com

Joe Salvatore, CT Port Authority, joseph.salvatore@ct.gov

Michael Passero, New London Mayor, mpassero@newlondonct.org

Michael Garbolski, AECOM, Michael.garbolski@aecom.com

Dennis Lowry, AECOM, Dennis.Lowry@aecom.com

Kris van Naerssen, AECOM, Kris.VanNaerssen@aecom.com

US ACOE, c/o Diane Ray, Diane.M.Ray@usace.army.mil, NAE #2018-02161

David Crocker, New London Harbormaster, crockerd64@gmail.com

Kathy Walburn, New London HMC, kwalburn@snet.com

Karen Michaels, CT DEEP LWRD, karen.michaels@ct.gov

Kevin Blacker, kjblacker@sbcglobal.net

Robert Fromer, saintrobert@comcast.net

Connecticut Department of Energy and Environmental Protection License*

Structures, Dredging & Fill and Tidal Wetlands Permit
Section 401 Water Quality Certification **

Licensee(s):	Connecticut Port Authority, c/o John Henshaw
Licensee Address(s):	455 Boston Post Road, Suite 204 Old Saybrook, CT 06475
License Number(s):	201905859-SDF TW WQC
Municipality:	City of New London
Project Description:	Conduct dredging with on site disposal, install a bulkhead, place fill and conduct other site improvements for marine industrial use.
Project Address/Location:	200 State Pier Road
Waters:	Thames River
Authorizing CT Statute(s) and/or Federal Law:	CGS Section 22a-359 to 363g; CGS Section 22a-90 to 112; Section 401 CWA (33 USC 1341); CGS Section 22a-28 to 35
Applicable Regulations of CT State Agencies:	22a-426-1 to 9, 22a-30-1 to 17
Agency Contact:	Land & Water Resources Division, Bureau of Water Protection & Land Reuse, 860-424-3019
License Expiration:	Seven (7) years from the date of issuance of this license.
Project Site Plan Set:	Thirty-five (35) Sheets of plans dated October 23, 2020, signed October 27 and October 28, 2020.
License Enclosures:	Compliance Certification Form, LWRD Dredging Report Form, Land Record Filing, LWRD Dredging and General Conditions, Site Plan Set, Work Commencement Form

*Connecticut's Uniform Administrative Procedure Act defines License to include, "the whole or part of any agency permit, certificate, approval, registration, charter or similar form of permission required by law . . ."

Authorized Activities:

The Licensee is hereby authorized to conduct the following work as described in application # 201905859-SDF TW WQC and as depicted on any site plan sheets / sets cited herein:

1. demolition of approximately 420 linear feet and approximately 84,000 square feet of the Admiral Shear State Pier (“State Pier”) to facilitate construction of the pile-supported East Face Heavy Lift Area;
2. demolition of approximately 34,000 square feet of select segments of the west face of State Pier concrete deck to facilitate fill placement;
3. demolition of approximately 1,500 square feet at the east face and approximately 1,500 square feet at the southeast corner of State Pier to facilitate mooring bollard installation identified below;
4. conduct dredging using mechanical or hydraulic dredging means approximately 55,000 cubic yards of material from an approximately 241,000 square foot area within the areas identified as the Turning Basin, including approaches to both berths to a depth of -36’ MLLW, with a 2’ allowable over-dredge;
5. conduct dredging using mechanical or hydraulic dredging means approximately 222,000 cubic yards of material from an approximately 240,000 square foot area within an area identified as the Northeast Bulkhead area to a depth of -38’ MLLW, with a 2’ allowable over-dredge for berthing layout and to -63’ MLLW with a 2’ allowable over-dredge for the seabed preparation work described below;
6. conduct dredging using mechanical or hydraulic dredging means approximately 122,000 cubic yards of material from an approximately 210,000 square foot area within an area identified as the East Berth area to a depth of -63’ MLLW, with a 2’ allowable over-dredge for berthing and seabed preparation work identified below;
7. conduct seabed preparation along the Northeast Bulkhead and East Berth rock pads, located adjacent to their respective Heavy Lift Areas for installation of crushed gravel areas to allow for berthing of vessels with jack up legs. Placement of up to 107,000 cubic yards of gravel in each dredged jack-up pocket area to a maximum thickness of 27’;
8. using either land or water-based equipment install longitudinal steel sheeting or protected slope at the Central Vermont Railroad (“CVRR”) Pier;
9. install a king pile bulkhead between the State Pier and the CVRR Pier, tying into the new longitudinal sheet pile wall/slope along the CVRR pier identified above;
10. place a total of approximately 400,000 cubic yards of fill material consisting of the dredged material identified above and upland fill material over an approximately 322,000 square foot area (approximately 7.4 acres) located between the CVRR Pier and State Pier to create the new Central Wharf with a finish grade of +9’ NAVD88;
11. install approximately 1,000 linear feet of steel sheet pile along the State Pier East Face;
12. remove or relocate existing stone riprap and place approximately 15,600 cubic yards of fill, consisting of pile structures, over an approximately 33,600 square foot area (0.77 acres) at the existing State Pier east Face;
13. install a series of approximately 3’ wide stone columns, or comparable technology, within the newly created Central Wharf and East Face Heavy Lift areas;
14. install approximately 1,115 linear feet of steel toewall at and adjacent to the base of the new State Pier East Face heavy Lift Area;
15. install upgraded energy-absorbing fender system and two (2) new mooring bollards at the State Pier;

16. install approximately 170 linear of steel sheetpile toewall along the waterward limit of an existing area of existing eelgrass bed with the height of the toewall extending approximately 1 foot above mudline;
17. install high mast lights with the limits of the new facility;
18. install cold ironing infrastructure;
19. construct a 16' wide by 16' long reinforced concrete pad immediately landward of an existing seawall and install four (4) 36" diameter pipe piles and associated gangway to support ConnDOT Chester-Hadlyme ferry overwintering at the Northwest Bulkhead area;
20. install three (3) 60' diameter and one (1) 54" diameter stormwater outfall pipes with one-way check valves discharging to the Thames River and associated bedding stone and stormwater treatment systems located on the upland; and
21. construct a living shoreline consisting of stone riprap, energy-dissipating concrete "reef balls", suitable organic sediment, and tidal wetland plantings located at the northern corner of the subject property.

Failure to comply with the terms and conditions of this license shall subject the Licensee and / or the Licensee's contractor(s) to enforcement actions and penalties as provided by law.

This license is subject to the following Terms and Conditions:

1. **License Enclosure(s) and Conditions.** The Licensee shall comply with all applicable terms and conditions as may be stipulated within the License Enclosure(s) listed above.
2. Prior to the commencement of the work authorized herein, the Licensee shall submit a copy of the FINAL Remedial Action Plan for the Commissioner's review and written approval. Upon receipt of the Commissioner's approval, the Licensee shall place the dredged sediment and upland soil between the existing State Pier and CVRR Pier in accordance with the FINAL Remedial Action Plan Connecticut State Pier, New London, Connecticut, dated June 2020 prepared for the Connecticut Department of Transportation by TRC Environmental Corporation. The Remedial Action Plan (RAP) is incorporated herein by reference.
3. The work authorized herein shall not commence until the US Army Corps of Engineers Federal Navigation Project Long Dock Branch Channel has been Congressionally deauthorized. The Licensee shall provide the Commissioner with a copy of the deauthorization.
4. Prior to the commencement of the work authorized herein, the Licensee shall file a Conditional Letter of Map Revision (CLOMR) with FEMA. Upon completion of the work authorized herein, the Licensee shall file a Letter of Map Revision (LOMR) with FEMA.
5. Prior to the commencement of the work authorized herein, the Licensee shall submit to the Commissioner for her review and written approval a Water Quality Monitoring Plan and a Turbidity Control Plan. The Licensee shall implement the measures of each plan upon receiving written approval by the Commissioner.
6. The Licensee shall assist the City of New London Port Authority in finding a suitable location for the existing commercial fishermen.
7. Within one hundred twenty (120) days following the issuance of this license, the Licensee shall sign the Escrow Agreement ("Agreement") identified in Exhibit A of this License and

- provide a signed copy of the Agreement to the Commissioner for her review and written approval.
8. Prior to the commencement of the work authorized herein, the Licensee shall demarcate the area of existing eelgrass and provide a 10' buffer around the area. The Licensee shall maintain the demarcation in optimal condition for the duration of the construction activities identified herein and shall avoid any work within this area.
 9. All unconfined in-water work shall be prohibited between June 1st through September 30th, inclusive, of any calendar year in order to protect spawning shellfish unless otherwise authorized in writing from the Commissioner.
 10. All work authorized herein shall not be conducted between April 1st through June 30th to protect Peregrine Falcons or the work shall be conducted in accordance with the DEEP NDDB Project Peregrine Falcon Protection Plan.
 11. Prior to the commencement of the work authorized herein the Licensee shall obtain all necessary local, state and federal authorizations for the work authorized by this license.
 12. The Licensee shall install and maintain floating turbidity curtains around the work area identified in **Authorized Activities** paragraphs 1. through 21., with the exception of the activities identified in paragraphs 4. through 7, above.
 13. Prior to the commencement of the work authorized herein, the Licensee shall submit to the Commissioner for her review and written approval a Living Shoreline Wetland Creation Plan. Such plan shall include a narrative description of the proposed living shoreline, methodology for construction, quantities of stone riprap for a proposed sill, volume and area of organic sediment, tidal wetland identification and plant density and associated plans. The Licensee shall implement the measures of each plan upon receiving written approval by the Commissioner.
 14. The Licensee shall conduct a minimum of a 3-year monitoring program which shall include the submission of an annual monitoring report on or before October 30th of each growing season for the Commissioner's review and comment. Such annual report shall contain at a minimum the following information: 1.) remedial actions taken during the monitoring year, such as: slope stabilization, replanting of upland vegetation, and controlling invasive plant species; 2.) visual estimates of percent cover of surviving vegetation; 3.) general health and vigor of the surviving plants; 4.) site photographs; and 5.) remedial measures recommended to achieve or maintain the slope stabilization of the restoration area. The Licensee shall immediately implement any additional remedial recommendations that may be prescribed by the Commissioner in writing. If the Commissioner determines following the 3-year monitoring program that the approved restoration plan has not been successful, the Licensee shall submit for review and written approval of the Commissioner a revised plan to achieve restoration at this site.
 15. The Licensee shall install and maintain water quality improvement measures on the upland and the one-way check valves on the outfall pipes authorized herein and shall maintain these improvements and valves in optimal condition for the life of the structures.
 16. All waste material generated by the performance of the work authorized herein shall be disposed of by the Licensee at an upland site approved for the disposal of such waste materials, as applicable. The Licensee shall ensure that no waste material enters the Thames River and must immediately remove any debris that enters the water.

17. On or before ninety (90) days after completion of the work authorized herein, the Licensee shall submit to the Commissioner an “as-dredged” survey of the work area showing contours, bathymetries, tidal datums, including any proposed elevation views and cross sections included in the license. Such plans or survey shall be the originals and be signed and sealed by an engineer, surveyor or architect, as applicable, who is licensed in the State of Connecticut.

Issued under the authority of the Commissioner of Energy and Environmental Protection on:

August 18, 2021

Date

Betsey Wingfield
Deputy Commissioner
Department of Energy & Environmental Protection

**The Department is reissuing the permit effective today to correct a clerical error, which resulted in the omission of certain documents that should have been attached to the permit dated August 13, 2021, namely the Fisheries Management/Mitigation Plan Escrow Agreement, the Peregrine Falcon Protection Plan, and a signed copy of the State Pier Infrastructure Improvement Plans in lieu of the unsigned plans.

LWRD Dredging and General Conditions

1. **Time-of-Year Restriction.** Unless otherwise noted in the License, unconfined in-water excavation, dredging, filling or removal of debris or other material is prohibited, inclusive, in any year from June 1 through September 30 in order to protect spawning shellfish in the area unless otherwise authorized in writing by the Commissioner.
2. **Dredging Report.** Not later than two (2) weeks subsequent to the completion of any dredging activity authorized herein, the Licensee shall submit to the Commissioner a completed Dredging Report. A separate form shall be submitted by the Licensee for each distinct dredging activity conducted pursuant to this license.
3. **Bottom Disturbance.** Dragging the bottom with a spoil barge, scow, vessel, beam or similar equipment outside of any authorized area is prohibited.
4. **Material Handling.** Sidecasting or in-water rehandling of dredged or excavated material is prohibited.
5. **Barge Control.** Spoil scows or barges shall be loaded and navigated in a manner which prevents uncontrollable motion or spillage and washout of dredged or excavated materials.
6. **Sale of Sediment.** Sediment dredged pursuant to the license shall not be sold nor shall any fee for its use be charged without the express prior written authorization of the Commissioner and payment of a \$4.00 per yard royalty to the state of Connecticut Department of Energy & Environmental Protection, pursuant to CGS section 22a-361(e).
7. **Sediment Disposal.** The Licensee shall dispose of aquatic sediments in accordance with the terms and conditions of the license.
8. **Submission of As-Dredged Plans.** On or before ninety (90) days after completion of the work authorized herein, the Licensee shall submit to the Commissioner an “as-dredged” survey of the work area showing contours, bathymetries, tidal datums and structures, as applicable. Such survey shall be the original one and be signed and sealed by an engineer, surveyor or architect, as applicable, who is licensed in the State of Connecticut.

Open Water Disposal, if authorized in Project Description

1. **Material Disposal.** The Licensee shall dispose of dredged or excavated material in accordance with the requirements of the United States Army Corps of Engineers-New England District, except that if the authorized disposal site is modified, the Licensee shall submit a request for modification of the location to the Commissioner and shall not dispose of the material until such location modification has been approved in writing by the Commissioner.

2. **Disposal Site / Use Modification.** The Commissioner may modify the authorized disposal site and direct dredged sediment to an alternate site for use as cap material, provided that no modification will take effect if such modification imposes uncompensated additional costs solely attributable to such modification on the Licensee.
3. **Disposal Monitoring.** The Licensee shall not dispose of dredged or excavated material unless said disposal is supervised and witnessed by an on-board inspector or documented by an automated disposal monitoring program approved by the United States Army Corps of Engineers-New England District.
4. **Barge Navigation.** Spoil scows or barges used by the Licensee for disposal of dredged or excavated material shall travel to and from the authorized disposal site utilizing sea lanes defined by the United States Army Corps of Engineers-New England District.
5. **Point Dumping.** The Licensee shall point-dump dredged or excavated materials at a specified buoy or set of coordinates identified by United States Army Corps of Engineers-New England District within the authorized disposal site.

LWRD General Conditions

1. **Land Record Filing.** The Licensee shall file the Land Record Filing on the land records of the municipality in which the subject property is located not later than thirty (30) days after license issuance pursuant to Connecticut General Statutes (CGS) Section 22a-363g. A copy of the Notice with a stamp or other such proof of filing with the municipality shall be submitted to the Commissioner no later than sixty (60) days after license issuance. If a Land Record Filing form is not enclosed and the work site is not associated with an upland property, no filing is required.
2. **Contractor Notification.** The Licensee shall give a copy of the license and its attachments to the contractor(s) who will be carrying out the authorized activities prior to the start of construction and shall receive a written receipt for such copy, signed and dated by such contractor(s). The Licensee's contractor(s) shall conduct all operations at the site in full compliance with the license and, to the extent provided by law, may be held liable for any violation of the terms and conditions of the license. At the work site, the contractor(s) shall, whenever work is being performed, have on site and make available for inspection a copy of the license and the authorized plans.
3. **Work Commencement.** Not later than two (2) weeks prior to the commencement of any work authorized herein, the Licensee shall submit to the Commissioner, on the Work Commencement Form attached hereto, the name(s) and address(es) of all contractor(s) employed to conduct such work and the expected date for commencement and completion of such work, if any.
 - For water diversion activities authorized pursuant to 22a-377(c)-1 of the Regulations of Connecticut State Agencies, the Licensee shall also notify the Commissioner in writing two weeks prior to initiating the authorized diversion.
 - For emergency activities authorized pursuant Connecticut General Statutes Section

22a-6k, the Licensee shall notify the Commissioner, in writing, of activity commencement at least one (1) day prior to construction and of activity completion no later than five (5) days after conclusion.

4. **License Notice.** The Licensee shall post the first page of the License in a conspicuous place at the work area while the work authorized therein is undertaken.
5. **Unauthorized Activities.** Except as specifically authorized, no equipment or material, including but not limited to, fill, construction materials, excavated material or debris, shall be deposited, placed or stored in any wetland or watercourse on or off-site. The Licensee may not conduct work within wetlands or watercourses other than as specifically authorized, unless otherwise authorized in writing by the Commissioner. Tidal wetlands means “wetland” as defined by section 22a-29 and “freshwater wetlands and watercourses” means “wetlands” and “watercourses” as defined by section 22a-38.
6. **Excavated Materials.** Unless otherwise authorized, all excavated material shall be staged and managed in a manner which prevents additional impacts to wetlands and watercourses.
7. **Best Management Practices.** The Licensee shall not cause or allow pollution of any wetlands or watercourses, including pollution resulting from sedimentation and erosion. In constructing or maintaining any authorized structure or facility or conducting any authorized activity, or in removing any such structure or facility, the Licensee shall employ best management practices to control storm water discharges, to prevent erosion and sedimentation, and to otherwise prevent pollution of wetlands and other waters of the State. For purposes of the license, “pollution” means “pollution” as that term is defined by CGS section 22a-423. Best Management Practices include, but are not limited, to practices identified in the *Connecticut Guidelines for Soil Erosion and Sediment Control* as revised, *2004 Connecticut Stormwater Quality Manual*, Department of Transportation’s *ConnDOT Drainage Manual* as revised, and the Department of Transportation Standard Specifications as revised.
8. **Work Site Restoration.** Upon completion of any authorized work, the Licensee shall restore all areas impacted by construction, or used as a staging area or accessway in connection with such work, to their condition prior to the commencement of such work.
9. **Inspection.** The Licensee shall allow any representative of the Commissioner to inspect the project location at reasonable times to ensure that work is being or has been conducted in accordance with the terms and conditions of this license.
10. **Change of Use. (Applies only if a use is specified within the License “Project Description”)**
 - a. The work specified in the license is authorized solely for the purpose set forth in the license. No change in purpose or use of the authorized work or facilities as set forth in the license may occur without the prior written approval of the Commissioner. The Licensee shall, prior to undertaking or allowing any change in use or purpose from that which is authorized by this license, request permission from the Commissioner for such change. Said request shall be in writing and shall describe the proposed change and the reason for the change.

b. A change in the form of ownership of any structure authorized herein from a rental/lease commercial marina to a wholly-owned common interest community or dockominium may constitute a change in purpose as specified in paragraph (a) above.

11. De Minimis Alteration. The Licensee shall not deviate from the authorized activity without prior written approval from the Commissioner. The Licensee may request a de minimis change to any authorized structure, facility, or activity. A de minimis alteration means a change in the authorized design, construction or operation that individually and cumulatively has minimal additional environmental impact and does not substantively alter the project as authorized.

- For diversion activities authorized pursuant to 22a-377(c)-2 of the Regulations of Connecticut State Agencies, a de minimis alteration means an alteration which does not significantly increase the quantity of water diverted or significantly change the capacity to divert water.

12. Extension Request. The Licensee may request an extension of the license expiration date. Such request shall be in writing and shall be submitted to the Commissioner at least thirty (30) days prior to the license expiration. Such request shall describe the work done to date, what work still needs to be completed, and the reason for such extension. It shall be the Commissioner's sole discretion to grant or deny such request.

13. No Work After License Expiration. Work conducted after the license expiration date is a violation of the license and may subject the licensee to enforcement action, including penalties, as provided by law.

14. License Transfer. The license is not transferable without prior written authorization of the Commissioner. A request to transfer a license shall be submitted in writing and shall describe the proposed transfer and the reason for such transfer. The Licensee's obligations under the license shall not be affected by the passage of title to the license site to any other person or municipality until such time as a transfer is approved by the Commissioner.

15. Document Submission. Any document required to be submitted to the Commissioner under the license or any contact required to be made with the Commissioner shall, unless otherwise specified in writing by the Commissioner, be directed to:

Regulatory Section
Land & Water Resources Division
Department of Energy and Environmental Protection
79 Elm Street
Hartford, Connecticut 06106-5127
860-424-3019

16. Date of Document Submission. The date of submission to the Commissioner of any document required by the license shall be the date such document is received by the Commissioner. The date of any notice by the Commissioner under the license, including but not limited to notice of approval or disapproval of any document or other action, shall be the date such notice is personally delivered or the date three (3) days after it is mailed by the

Commissioner, whichever is earlier. Except as otherwise specified in the license, the word “day” as used in the license means calendar day. Any document or action which is required by the license to be submitted or performed by a date which falls on a Saturday, Sunday or a Connecticut or federal holiday shall be submitted or performed on or before the next day which is not a Saturday, Sunday, or a Connecticut or federal holiday.

- 17. Certification of Documents.** Any document, including but not limited to any notice, which is required to be submitted to the Commissioner under the license shall be signed by the Licensee and by the individual or individuals responsible for actually preparing such document, each of whom shall certify in writing as follows: “I have personally examined and am familiar with the information submitted in this document and all attachments and certify that based on reasonable investigation, including my inquiry of those individuals responsible for obtaining the information, the submitted information is true, accurate and complete to the best of my knowledge and belief, and I understand that any false statement made in this document or its attachments may be punishable as a criminal offense.”
- 18. Accuracy of Documentation.** In evaluating the application for the license, the Commissioner has relied on information and data provided by the Licensee and on the Licensee’s representations concerning site conditions, design specifications and the proposed work, including but not limited to representations concerning the commercial, public or private nature of the work or structures, the water-dependency of said work or structures, its availability for access by the general public, and the ownership of regulated structures or filled areas. If such information proves to be false, deceptive, incomplete or inaccurate, the license may be modified, suspended or revoked, and any unauthorized activities may be subject to enforcement action.
- 19. Limits of Liability.** In granting the license, the Commissioner has relied on all representations of the Licensee, including information and data provided in support of the Licensee’s application. Neither the Licensee’s representations nor the issuance of the license shall constitute an assurance by the Commissioner as to the structural integrity, the engineering feasibility or the efficacy of such design.
- 20. Reporting of Violations.** In the event that the Licensee becomes aware that they did not or may not comply, or did not or may not comply on time, with any provision of this license or of any document incorporated into the license, the Licensee shall immediately notify the agency contact specified within the license and shall take all reasonable steps to ensure that any noncompliance or delay is avoided or, if unavoidable, is minimized to the greatest extent possible. In so notifying the agency contact, the Licensee shall provide, for the agency’s review and written approval, a report including the following information:
 - a. the provision(s) of the license that has been violated;
 - b. the date and time the violation(s) was first observed and by whom;
 - c. the cause of the violation(s), if known;
 - d. if the violation(s) has ceased, the duration of the violation(s) and the exact date(s) and times(s) it was corrected;

- e. if the violation(s) has not ceased, the anticipated date when it will be corrected;
- f. steps taken and steps planned to prevent a reoccurrence of the violation(s) and the date(s) such steps were implemented or will be implemented; and
- g. the signatures of the Licensee and of the individual(s) responsible for actually preparing such report.

If the violation occurs outside of normal business hours, the Licensee shall contact the Department of Energy and Environmental Protection Emergency Dispatch at 860-424-3333. The Licensee shall comply with any dates which may be approved in writing by the Commissioner.

- 21. Revocation/Suspension/Modification.** The license may be revoked, suspended, or modified in accordance with applicable law.
- 22. Other Required Approvals.** License issuance does not relieve the Licensee of their obligations to obtain any other approvals required by applicable federal, state and local law.
- 23. Rights.** The license is subject to and does not derogate any present or future property rights or powers of the State of Connecticut, and conveys no property rights in real estate or material nor any exclusive privileges, and is further subject to any and all public and private rights and to any federal, state or local laws or regulations pertinent to the property or activity affected hereby.
- 24. Condition Conflicts.** In the case where a project specific special condition listed on the license differs from, or conflicts with, one of the general conditions listed herein, the project specific special condition language shall prevail. It is the licensee's responsibility to contact the agency contact person listed on the license for clarification if needed prior to conducting any further regulated activities.



Land Record Filing*

To: City of New London Clerk

Signature and

NOTE: Due to the electronic delivery of this license and the legal requirement to have a live signature on this document, the “Land Record Filing” as detailed in General Condition #1 will be sent to you via U.S. Mail.

Date:

Subject: State Pier, 200 State Pier Road, New London
License #201905859-SDF TW WQC

If you have any questions pertaining to this matter, please contact the Land & Water Resources Division at 860-424-3019.

Return to:

Land & Water Resources Division
State of Connecticut
Department of Energy & Environmental Protection
79 Elm Street
Hartford, CT 06106-5127

*The Licensee shall file the Land Record Filing on the land records of the municipality in which the subject property is located not later than thirty (30) days after license issuance pursuant to Connecticut General Statutes (CGS) Section 22a-363g. A copy of the Notice with a stamp or other such proof of filing with the municipality shall be submitted to the Commissioner no later than sixty (60) days after license issuance.



Work Commencement Form

To: Regulatory Section
Department of Energy and Environmental Protection
Land & Water Resources Division
79 Elm Street
Hartford, CT 06106-5127

Licensee Name: _____

Municipality in which the project is occurring: _____

DEEP License No(s): _____

CONTRACTOR(s):

1 Name: _____
Address: _____
Telephone: _____
E-mail: _____

2 Name: _____
Address: _____
Telephone: _____
E-mail: _____

3 Name: _____
Address: _____
Telephone: _____
E-mail: _____

Date Contractor(s) received a copy
of the license and approved plans: _____

EXPECTED DATE OF COMMENCEMENT OF WORK: _____

EXPECTED DATE OF COMPLETION OF WORK: _____

LICENSEE: _____
(Signature)

(Date)



DREDGING REPORT
(To be completed by Licensee)

License No(s): _____
Licensee Name: _____
Address of Dredging Activity: _____

Dredging Contractor Information:

Name: _____
Mailing Address: _____
Business Phone: _____
Contact Person: _____
E-mail: _____

Dates Dredged: _____
Total Volume Dredged during this period: _____
Disposal Volume(s) and Location(s): _____

**If any portion of the dredged materials was used in a beneficial manner, please identify the beneficial use type (i.e. beach nourishment, habitat restoration, landfill cap, construction materials...), volume of dredged material utilized and the location of beneficial usage.

Document Certification:

“I have personally examined and am familiar with the information submitted in this document and all attachments and certify that based on reasonable investigation, including my inquiry of those individuals responsible for obtaining the information, the submitted information is true, accurate and complete to the best of my knowledge and belief, and I understand that any false statement made in this document or its attachments may be punishable as a criminal offense.”

Signature of Licensee Date _____

If you have any questions pertaining to this form, please contact the Land & Water Resources Division at 860-424-3034.

Return to:
Land & Water Resources Division
State of Connecticut Department of Energy & Environmental Protection
79 Elm Street
Hartford, CT 06106-5127

Fisheries Management/Mitigation Plan Escrow Agreement

This Fisheries Management/Mitigation Plan Escrow Agreement (“Agreement”) is made and entered into as of the _____ day of _____, 20__, by and among the Connecticut Port Authority (“CPA”) and **Selected Financial Institution** (“AGENT”). CPA and the AGENT are sometimes referred to herein individually as a “Party” and collectively as the “Parties.”

RECITALS

WHEREAS, CPA received a Structures, Dredge and Fill and Tidal Wetlands Permit and a Section 401 Water Quality Certification from the State of Connecticut Department of Energy & Environmental Protection (“DEEP”) to construct certain improvements at the State Pier facility in New London, Connecticut (License # 201905859-SDF TW WQC dated _____ [“License”]), and as a condition of such License and as mitigation for resource impacts, agreed to fund fish habitat restoration projects acceptable to DEEP in accordance with the terms of the License;

WHEREAS, DEEP has advised CPA that the projects described in this Agreement to restore the passage of alewife, blueback herring, and other fish species to habitat currently unavailable to said species due to the presence of dams or other obstructions is acceptable to DEEP and will satisfy all conditions in the License relating to mitigation of resource impacts through fish habitat restoration;

WHEREAS, DEEP has entered into agreements with sponsors of fish habitat restoration projects (such agreements referred to individually as a “Project Sponsor Commitment”) to sponsor the fish habitat restoration projects described below; and,

WHEREAS, the AGENT agrees to act as AGENT and hold the funds deposited by CPA and distribute them in accordance with the terms of this Agreement;

NOW THEREFORE, in consideration of the mutual promises, undertaking, and covenants hereinafter contained, and other good and valuable consideration, the receipt and sufficiency of which is hereby acknowledged, the Parties hereto intending to be legally bound agree as follows:

I. Identification of Fish Habitat Restoration Projects

- A. DEEP has identified fish habitat restoration projects (each referred to individually as the “Project”, and collectively as the “Projects”) that would provide adequate mitigation for resource impacts by reconnecting areas of fish habitat that are currently inaccessible and, therefore, not productive. DEEP has also established the maximum amount of funding each Project would receive from the CPA funding. The Projects have been categorized as Tier I, which are currently in active development and would be ready for implementation with approximately twelve (12) months from the date of this Agreement, and Tier II, which have been identified in the event that a Tier I Project cannot be implemented due to unresolvable issues, including, but not limited to, land ownership, design obstructions, time of year restrictions, and/or the failure to obtain all necessary regulatory permits.

B. Tier I Projects.

Project Name	Stream	Town	Project Sponsor ¹	Maximum Contribution to Project ²
Post Office- R	Beaver Brook	Sprague	Town of Sprague	\$150,000
Harrington Apt- R	Beaver Brook	Sprague	Town of Sprague	
Highland Pond- R	Sawmill Brook	Middletown	Middlesex Land Trust	\$200,000
Shewville- F	Indiantown Brook	Ledyard	ECCD	\$200,000
Bulkley Pond- R	Sasco Brook	Westport/Fairfield	TBD	\$100,000
Long Pond- F	Whitford Brook	Ledyard	STS	\$200,000
Bristol Brass- R	Pequabuck River	Bristol	TBD	\$500,000
Winchell-Smith- F	Farmington River	Farmington	Conn. River Salmon Assoc.	\$500,000
Upper Millpond- F	Indian River	Clinton	Town of Clinton	\$500,000
Griswold #4- R	Pattaconk Brook	Chestser	Conn. River Conservancy	\$425,000
Grannis Pond- F	Eightmile River	Southington	Save the Sound	\$300,000
Roaring Brook- F	Roaring Brook	Lyme	Conn. River Salmon Assoc.	\$200,000
R= removal F= fishway				

C. Tier II Projects.

Project Name	Stream	Town	Project Sponsor ¹	Maximum Contribution to Project ²
Wards Mill	Branford River	Branford	TBD	TBD
Parke Pond	Shunnock River	Stonington	TBD	TBD
Merwin Meadows	Norwalk River	Wilton	Save the Sound	TBD
Roses Mill Pond	Indian River	Milford	Save the Sound	TBD
Indian Lake	Indian River	Milford	Save the Sound	TBD
Schwartz Pond	Stony Brook	Suffield	Connecticut River Salmon Assoc.	TBD
Starr Mill Dam	Coginchaug River	Middletown	Connecticut River Salmon Assoc.	TBD
Johnsonville	Moodus River	East Haddam	Connecticut River Salmon Assoc.	TBD
Witch Hazel	West River	Guilford	TBD	TBD
Deer Lake	Chatfield Hollow Br	Madison	TBD	TBD
Largo Drive	Noroton River	Stamford	Save the Sound	TBD
Nickson	Quinnipiac River	Plainville	Save the Sound	TBD
Chasmar	Fivemile River	Darien/Norwalk	Save the Sound	TBD
Haleys Brook dams	Haley's Brook	Groton	Save the Sound	TBD
Stillman Pond	Yellow Mill Channel	Bridgeport	Save the Sound	TBD
Mill River Tide Gates	Mill River	New Haven	Save the Sound	TBD
Millers Pond	Hunts Brook	Waterford	TBD	TBD
Tingue Dam Fishway	Naugatuck River	Seymour	Town of Seymour	TBD
(continued next page)				

¹ Hereinafter, referred to individually as a "Project Sponsor," and collectively as "Project Sponsors," which includes sponsors of both Tier I and Tier II Projects. Project Sponsors may also be more specifically referred to as "Tier I Project Sponsors" or "Tier II Project Sponsors," or in the singular as a "Tier I Project Sponsor" or "Tier II Project Sponsor."

² Hereinafter, the amount identified in this column, or (if this column does not provide an amount) the amount later determined by DEEP as part of its review of a Project proposal to be the Maximum Contribution to Project, is referred to as the "Maximum Contribution to Project."

Project Name	Stream	Town	Project Sponsor ¹	Maximum Contribution to Project ²
Tier II Projects (Continued)				
Last Pond	Pine Brook	North Haven	TBD	TBD
Bladen Brook	Bladen Brook	Seymour	TBD	TBD
Papermill Pond	Little River	Sprague	Town of Sprague	TBD
Whitford Pond	Whitford Brook	Ledyard	TBD	TBD

II. Effective Date

This Agreement shall be effective as of the date CPA deposits the sum of **XXX,XXX** Thousand Dollars (**\$XXX,000.00**) (the “Funds”) with the AGENT by delivering a certified check in that amount to: **[insert instructions from Selected Financial Institution]**

III. Obligations of CPA

- A. CPA agrees to pay for the services of AGENT in accordance with Schedule A hereto.
- B. CPA shall indemnify and hold harmless AGENT and each director, officer, employee and affiliate of AGENT (each, an “Indemnified Party”) upon demand against any and all claims, actions and proceedings (whether asserted or commenced by CPA or any other person or entity and whether or not valid), losses, damages, liabilities, penalties, costs and expenses of any kind or nature (including without limitation reasonable attorneys’ fees, costs and expenses (collectively, “Losses”) arising from this Agreement or AGENT’s performance of duties or enforcement of rights hereunder, except to the extent such Losses are finally determined by a court of competent jurisdiction, which determination is not subject to appeal, to have been directly caused solely by the gross negligence or willful misconduct of such Indemnified Party in connection with AGENT’s material breach of this Agreement. CPA’s obligations under this Section III.B shall survive any termination of this Agreement and the resignation or removal of AGENT.

IV. Obligations of AGENT

- A. Hold Funds. The AGENT shall hold the Funds deposited by CPA pursuant to Section II, above, un-invested and separately from other monies held by AGENT. Funds shall be invested by the AGENT in the investment identified in Schedule B.
- B. Disburse Funds. The AGENT shall only disburse the Funds to a Project Sponsor that has signed and submitted a Project Sponsor Commitment as confirmed by DEEP to the AGENT in writing. Promptly after receipt of such DEEP confirmation, the AGENT shall disburse to each of the Tier I Project Sponsors the applicable Maximum Contribution to Project amount identified in Section I.B, above.
- C. Accounting of Funds. The AGENT will provide DEEP and CPA an annual report on the status of the Funds until such Funds are fully expended or transferred pursuant to Section VI.C, below, the escrow account is closed, and this Agreement is terminated pursuant to Section XI, below. Such annual report will list each payment from the Funds, and disclose the recipient of the Funds, the Project to which the Funds were disbursed, the amount disbursed, and the date disbursed. The AGENT will also provide to DEEP and CPA the report required by Section VI.B, below, when so requested by DEEP. DEEP and CPA may

also request that the AGENT provide a status report regarding the Funds at any time, containing the same information as the annual report, and the AGENT will have thirty (30) days to provide such a report.

- D. Final Report. After all Funds are fully expended or transferred pursuant to Section VI.C, below, the escrow account is closed, and this Agreement is terminated pursuant to Section XI, below, the AGENT will provide DEEP and CPA a final report on the disbursement of the Funds. Such report will list each payment from the Funds, and disclose the recipient of the Funds, the Project to which the Funds were disbursed, the amount disbursed, and the date disbursed.

V. Replacement of Sponsor

If the original Project Sponsor is unable to complete a Project to which Funds have been disbursed, DEEP may attempt to recruit another organization to manage the same Project using the disbursed Funds. If a replacement Project Sponsor is not selected and the AGENT does not receive a Project Sponsor Commitment as confirmed by DEEP in writing within six (6) months, the Project will be deemed terminated and Section VI, below, shall apply to any Funds returned by a Project Sponsor to the AGENT.

VI. Disposition of Unspent Funds

- A. Transfer of Unspent Funds from a Tier I Project. If a Tier I Project Sponsor does not spend the Maximum Contribution to Project Amount, for any reason, including termination of the Project or completion of the Project for less than the Maximum Contribution to Project Amount, the Tier I Project Sponsor shall return the unspent portion of the Maximum Contribution to Project Amount to the AGENT and such Funds, to the extent so returned and notwithstanding the provision in Section IV.B, above, that Project Sponsor shall only receive the Maximum Contribution to Project Amount, shall be available to be transferred to another Tier I Project pursuant to direction in writing from DEEP to the AGENT.
- B. Transfer of Unspent Funds to Tier II Project. Within thirty (30) days of being notified by DEEP that the Tier I projects have been completed or otherwise terminated, the AGENT shall submit an accounting of the Funds to DEEP. If all Funds have been disbursed, this accounting shall be the Final Report required by Section IV.D, above. If there are unspent Funds returned to AGENT pursuant to Section VI.A remaining in the account, DEEP shall thereafter identify Tier II Projects to which the Funds may be applied and alert the sponsors of such projects of the availability of the unspent Funds. Tier II Project Sponsors must submit a Project Sponsor Commitment as approved by DEEP in writing in order to receive any portion of the unspent Funds pursuant to direction in writing from DEEP to the AGENT. This process shall be repeated until all of the Funds are expended or transferred pursuant to Section VI.C, below.
- C. Transfer of Unspent Funds from Escrow Account. If no new Project Sponsor commits to use the unspent Funds for a period of five (5) years after the last payment by the AGENT to a Project Sponsor, the unspent Funds shall be disbursed by AGENT, pursuant to DEEP's written direction, to a private tax-exempt entity selected by DEEP, in its sole discretion and judgment, whose purpose is environmental conservation and restoration.

VII. AGENT's Standard of Care

The AGENT may act in reliance upon any writing or instrument or signature which it in good faith believes to be genuine, may assume the validity and accuracy of any statement or assertion contained in such a writing or instrument, and may assume that any person purporting to give any writing, notice, advice or instructions in connection with the provisions hereof has been duly authorized to do so. The AGENT shall not be liable in any manner for the sufficiency or correctness as to form, manner and execution, or validity of any instrument deposited in this escrow account, nor as to the identity, authority, or right of any person executing the same. AGENT undertakes to perform only such duties as are expressly set forth herein and no duties will be implied. AGENT has no fiduciary or discretionary duties of any kind. AGENT's permissive rights will not be construed as duties. AGENT has no liability under and no duty to inquire as to the provisions of the License, any Project Sponsor Commitment, or any document other than this Agreement, including without limitation any other agreement between any or all of the parties hereto or any other persons even though reference thereto may be made herein and whether or not a copy of such document has been provided to AGENT. AGENT will not be liable for any action taken or omitted by it in good faith except to the extent that a court of competent jurisdiction determines, which determination is not subject to appeal, that AGENT's gross negligence of willful misconduct in connection with its material breach of this Agreement was the sole cause of any loss to CPA. In no event will AGENT be liable for (i) acting in accordance with or conclusively relying upon any instruction, notice, demand, certificate or document believed by AGENT to have been created by or on behalf of CPA or DEEP, (ii) incidental, indirect, special, consequential or punitive damages or penalties of any kind (including, but not limited to lost profits), even if AGENT has been advised of the likelihood of such damages or penalty and regardless of the form of action AGENT may consult, at CPA's cost, legal counsel selected by it in the event of any dispute or question as to the construction of any of the provisions hereof or of any other agreement or of its duties hereunder, or relating to any dispute involving this Agreement, and will incur no liability and must be fully indemnified by CPA from any liability whatsoever in acting in accordance with the advice of such counsel. AGENT will not be obligated to take any legal action in connection with the Funds, this Agreement or any other agreement or to appear in, prosecute or defend any such legal action or to take any other action that in AGENT's sole judgment may expose it to potential expense or liability.

VIII. Resignation of AGENT

The AGENT may at any time resign upon thirty (30) days written notice to CPA and DEEP and CPA may remove AGENT as AGENT under this Agreement upon thirty (30) days notice to AGENT. CPA shall appoint a successor AGENT, with the advice and consent of DEEP, which consent shall not be unreasonably withheld, within this thirty (30) day period.

IX. Representations and Warranties

Each of the Parties represents and warrants to each other that such Party has full power and authority to enter into and perform its obligations under this Agreement, and all action necessary to authorize the execution and delivery of this Agreement and the performance by such Party of its obligations hereunder has been taken. This Agreement has been duly executed by such Party and constitutes the legal, valid, binding and enforceable obligation of such Party, enforceable against such Party in accordance with its terms subject to bankruptcy laws affecting creditors' rights generally.

X. Submission of Materials

All notices, reports, consents, approvals and requests or permitted hereunder shall be in writing, and shall be either hand delivered or sent, by (a) certified or registered U.S. Mail, Return Receipt Requested, first class postage prepaid, or (b) expedited prepaid delivery service, either commercial (e.g., Federal Express or comparable national courier) or U.S. Postal Service, with proof of attempted delivery. All notices shall be addressed to the following:

If to CPA:

Connecticut Port Authority
Attn: Joseph Salvatore
455 Boston Post Rd
Old Saybrook, CT 06475

If to DEEP:

Dept. of Energy and Environmental Protection
Land & Water Resources Division
Attn: Micheal Grzywinski
79 Elm Street
Hartford, CT 06106

and

Dept. of Energy and Environmental Protection
Attn: Peter Aarrestad
Director, Fisheries Division
79 Elm Street
Hartford, CT 06106

If to AGENT:

Selected Financial Institution

Attn: _____
Street
City, State, Zip

The Parties and DEEP may change the recipient of its notices at any time by sending notice of the change pursuant to this Section.

XI. Termination of Agreement

- A. This Agreement shall terminate upon the occurrence of any of the following events:
 - (1) The payment of all Funds by the AGENT to Project Sponsors.
 - (2) The transfer of any unspent Funds pursuant to Section VI.C, above.
- B. Upon termination of this Agreement, the AGENT will close the escrow account and submit the Final Report required by Section IV.D, above.

XII. General Provisions

- A. Entire Agreement. This Agreement constitutes the entire agreement between the Parties pertaining to its subject matter, and it supersedes any and all written or oral agreements previously existing between the Parties with respect to such subject matter.
- B. Amendment. No amendment of any provision of this Agreement shall be valid unless the same shall be in writing and signed by each of the Parties.
- C. No Agency or Partnership. Nothing contained in this Agreement shall constitute CPA as a joint venture, partner or agent of the Project Sponsors or any recipient of the Funds, or render CPA liable for any interests, obligations, acts, omissions, representations or contracts of the Project Sponsors or any recipient of the Funds.
- D. Waiver. Any Party's failure to insist on strict performance of this Agreement shall not be deemed a waiver of any of its rights or remedies, nor shall it relieve any other Party from performing any subsequent obligation strictly in accordance with the terms of this Agreement. No waiver shall be effective unless it is in writing and signed by the Party against whom enforcement is sought. Such waiver shall be limited to provisions of this Agreement specifically referred to therein and shall not be deemed a waiver of any other provision. No waiver shall constitute a continuing waiver unless the writing states otherwise.
- E. Assignment; Successors and Assigns. This Agreement shall be binding upon and inure to the benefit of the Parties named herein and their respective successors and permitted assigns. No Party may assign either this Agreement or any of its rights, interests, or obligations hereunder without the prior written approval of the other Parties.
- F. Miscellaneous. The Section headings of this Agreement are for convenience of reference only and do not form a part hereof and do not in any way modify, interpret, or construe the intentions of the Parties. This Agreement may be executed in two or more counterparts and all such counterparts shall constitute one and the same instrument. Delivery of an executed signature page to this Agreement by facsimile transmission shall be as effective as delivery of a manually signed counterpart of this Agreement. The term "including" is by way of example and not limitation.
- G. Governing Law. This Agreement shall be governed by and construed in accordance with the laws of the State of Connecticut, without giving effect to the conflict of laws principles thereof.
- H. Severability. If any term or provision of this Agreement shall be held to be invalid or unenforceable for any reason by a court of competent jurisdiction, such term or provision shall be ineffective to the extent of such invalidity or unenforceability without invalidating the remaining

terms and provisions hereof, and this Agreement shall be construed as if such invalid or unenforceable term or provisions had not been contained herein.

- I. Parties in Interest. Except as specifically contemplated hereby, nothing in this Agreement is intended to confer any rights or remedies on any persons other than the Parties. For the avoidance of doubt, this Agreement confers no rights or remedies to any Project Sponsor or DEEP. This Agreement shall not be construed to relieve or discharge any obligations or liabilities of third persons, nor shall it be construed to give third persons any right of subrogation or action over or against any Party.
- J. Identifying Information. To help the government fight the funding of terrorism and money laundering activities, federal law requires all financial institutions to obtain, verify and record information that identifies each person who opens an account. For a non-individual person such as a business entity, a charity, a trust or other legal entity, AGENT requires documentation to verify its formation and existence as a legal entity. AGENT may require financial statements, licenses or identification and authorization documents from individuals claiming authority to represent the entity or other relevant documentation. CPA agrees to provide all information requested by AGENT in connection with any legislation or regulation to which AGENT is subject, in a timely manner.

Connecticut Port Authority

By: _____

Its _____

Duly Authorized

Selected Financial Institution

By: _____

Its _____

Duly Authorized

Approved

The State of Connecticut Department of Energy and Environmental Protection

By: _____

Its _____

Duly Authorized

DRAFT

SCHEDULE A

Selected Financial Institution

Schedule of Fees for Services

DRAFT

SAMPLE SCHEDULE B

Selected Financial Institution
Investment Authorization Form

Selected Financial Institution MONEY MARKET DEPOSIT ACCOUNT

Description and Terms

The **Selected Financial Institution** Money Market Deposit Account is a **Selected Financial Institution** ("XXXX") interest-bearing money market deposit account designed to meet the needs of **Selected Financial Institution Corporate Trust Services Escrow Group** and other corporate trust customers of **Selected Financial Institution**. Selection of this investment includes authorization to place funds on deposit and invest with **Selected Financial Institution**.

Selected Financial Institution uses the daily balance method to calculate interest on this account (actual/365 or 366). This method applies a daily periodic rate to the principal balance in the account each day. Interest is accrued daily and credited monthly to the account. Interest rates are determined at **Selected Financial Institution** discretion and may be tiered by customer deposit amount.

The owner of the account is **Selected Financial Institution** as agent for its corporate trust customers. **Selected Financial Institution** Corporate Trust Services Escrow Group performs all account deposits and withdrawals. Deposits accounts are FDIC insured per depositor, as determined under FDIC Regulations, up to applicable FDIC limits.

Selected Financial Institution IS NOT REQUIRED TO REGISTER AS A MUNICIPAL ADVISOR WITH THE SECURITIES AND EXCHANGE COMMISSION FOR PURPOSES OF COMPLYING WITH THE DODD-FRANK WALL STREET REFORM & CONSUMER PROTECTION ACT. INVESTMENT ADVICE, IF NEEDED, SHOULD BE OBTAINED FROM YOUR FINANCIAL ADVISOR.

Automatic Authorization

In the absence of specific written direction to the contrary to the extent and as authorized in the applicable escrow agreement, **Selected Financial Institution** is hereby directed to invest and reinvest proceeds and other available moneys in the **Selected Financial Institution** Money Market Deposit Account. The customer(s) confirm that the **Selected Financial Institution** Money Market Deposit Account is a permitted investment under the operative documents and this authorization is the permanent direction or investment of the moneys until notified in writing of permissible alternate instructions.



Connecticut Department of
**ENERGY &
ENVIRONMENTAL
PROTECTION**

July 22, 2019

Richard E. Couch
Martinez Couch & Associates, LLC
1084 Cromwell Avenue
Rocky Hill, CT 06067
couchre@martinezcouch.com

Project: Proposed Demolition of Various Upland Buildings, Installation of New Structures Including Storm Water Retention & Treatment System, Addition of Administrative Offices with Parking and Maintenance Dredging at the State Pier at 200 State Pier Road in New London, Connecticut
NDDB Determination No.: 201901490 (REVISED)

Dear Richard Couch,

I have reviewed Natural Diversity Data Base maps and files regarding the area delineated on the map provided for the Proposed Demolition of Various Upland Buildings, Installation of New Structures Including Storm Water Retention & Treatment System, Addition of Administrative Offices with Parking and Maintenance Dredging at the State Pier at 200 State Pier Road in New London, Connecticut. We have known extant records for State Threatened *Falco Peregrinus* (peregrine falcon) and State Special Concern blueback herring that occur in close proximity to your project boundaries.

Please be advised that a DEEP Fisheries Biologist will review the permit applications you may submit to DEEP regulatory programs to determine if your project could adversely affect blueback herring. DEEP Fisheries Biologists are routinely involved in pre-application consultations with regulatory staff and applicants in order to identify potential fisheries issues and work with applicants to mitigate negative effects, including to endangered species. If you have not already talked with a Fisheries Biologist about your project, you may contact the Permit Analyst assigned to process your application for further information, including the contact information for the Fisheries Biologist assigned to review your application

Peregrine Falcon (*Falco peregrinus*) Protection Status: Threatened Species

The peregrine falcon is a state threatened species which has adapted to life in urban settings. The peregrine falcon is associated with bridges for nesting and brood rearing purposes. Peregrines will actively and aggressively defend the nest, whether a nest box or natural nest, up to and sometimes past 75 yards. The peregrine will attack anyone or anything that comes within the area of its nest. Peregrine falcons are Connecticut's largest falcon and can measure up to 20 inches. Adults are slate gray above and pale underneath with fine bars and spots of black; they have long pointed wings with a narrow tail. Young falcons have the same composite but are darker underneath and browner all over. The peregrine falcon nesting season occurs between the months of April and June. For this reason, special conditions regarding the timing of work on the structure must be applied. In order to protect this species, the proposed construction activities should be completed during non-nesting season months (July – March). No construction activities should occur between April 1st and June 30th.

Protection Recommendation:

In order to protect this species, the proposed construction activities should be completed during non-nesting season months (July – March). No construction activities should occur between April 1st and June 30th. If work needs to be conducted during the breeding season (April 1st to June 30th) then I recommend hiring an ornithologist (bird expert) to evaluate and prepare a protection plan for the birds. All work on this project must maintain a minimum buffer of 300' from the nest. If a nest is identified by workers all work should stop immediately and this information should be reported to our program for further assistance and guidance to complete the work safely. I concur with the Peregrine Falcon Protection Plan that was submitted to our program on July 2, 2019 by Timothy O'Sullivan of

AECOM. If the Peregrine Falcon Protection Plan is followed it will minimize adverse impacts on the Peregrine Falcon.

Please re-submit an NDDB Request for Review if the scope of work changes or if work has not begun on this project by July 22, 2021.

Natural Diversity Data Base information includes all information regarding critical biological resources available to us at the time of the request. This information is a compilation of data collected over the years by the Department of Energy and Environmental Protection's Natural History Survey and cooperating units of DEEP, private conservation groups and the scientific community. This information is not necessarily the result of comprehensive or site-specific field investigations. Consultations with the Data Base should not be substitutes for on-site surveys required for environmental assessments. Current research projects and new contributors continue to identify additional populations of species and locations of habitats of concern, as well as, enhance existing data. Such new information is incorporated into the Data Base as it becomes available. The result of this review does not preclude the possibility that listed species may be encountered on site and that additional action may be necessary to remain in compliance with certain state permits.

Please contact me if you have further questions at (860) 424-3592, or dawn.mckay@ct.gov . Thank you for consulting the Natural Diversity Data Base.

Sincerely,

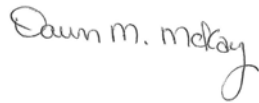
A handwritten signature in cursive script that reads "Dawn M. McKay".

Dawn M. McKay
Environmental Analyst 3



Peregrine Falcon Protection Plan

State Pier Infrastructure Improvements
New London, Connecticut

July 2, 2019

Quality information

<u>Prepared by</u>	<u>Checked by</u>	<u>Verified by</u>	<u>Approved by</u>
Timothy O'Sullivan Wetland and Wildlife Biologist	Patrick Fellion Environmental Scientist		

Revision History

<u>Revision</u>	<u>Revision date</u>	<u>Details</u>	<u>Authorized</u>	<u>Name</u>	<u>Position</u>

Distribution List

<u># Hard Copies</u>	<u>PDF Required</u>	<u>Association / Company Name</u>

Prepared for:

Connecticut Port Authority
State Pier Facility
New London, Connecticut

Prepared by:

Timothy O'Sullivan
Wetland and Wildlife Biologist
T: 978-621-6756
E: tim.osullivan@aecom.com

AECOM
500 Enterprise Drive
Rocky Hill, CT 06067
aecom.com

Copyright © 2019 by AECOM

All rights reserved. No part of this copyrighted work may be reproduced, distributed, or transmitted in any form or by any means without the prior written permission of AECOM.

Photos by NYS Thruway Authority

Table of Contents

1.0	Introduction and Project Description	1
2.0	Peregrine Falcon Physical Description and Habitat	3
2.1	Life History.....	3
3.0	Peregrine Falcon Protection Provisions	4
3.1	Construction Phase Contractor Awareness Program.....	4
3.2	Construction Phase Survey and Monitoring Plan.....	4
3.3	Coordination with CT DEEP.....	5
3.4	Reporting Requirements.....	5

Attachment A State Pier Facility, Site Locus

Attachment B CT DEEP/NDDB March 19, 2019 Response Letter

Attachment C Peregrine Falcon Fact Sheet

Attachment D Peregrine Falcon Monitoring Report, Hudson River Crossing Project

Attachment E Construction Monitoring Report Form

1.0 Introduction and Project Description

The existing State Pier Facility in New London Connecticut (Attachment A) encompasses nearly 30 acres and has three general operational areas: the piers (State Pier and Central Vermont Railroad), near dock shoreline areas, and offsite areas. The offsite areas comprise about one-fourth of the overall acreage and are situated north of and separated from the main port facility by State Pier Road and Amtrak's rail corridor embankment. The property generally consists of unpaved, gravel surfaces that are uneven or contain small depressions that pond water during storm events. The offsite areas are segmented by the rail siding to State Pier and bisected by the bridge piers for I-95's Gold Star Memorial Bridge. The property is bounded to the west by the New England Central Railroad (NECR) tracks and to the east by the Thames River.

The near-dock shoreline areas are south of State Pier Road and accommodate most of the port's cargo intermodal activity. This area contains two heavy load warehouse buildings totaling 102,000 square feet with railcar and truck loading docks, two 3,200-square-foot equipment/forklift maintenance buildings and an administration building. The area located at the head of the two piers is largely paved to facilitate forklift and tractor trailer movements. The shore edge consists of a combination of sheet piling, pile-supported docks, and stone block quay walls. The western portion of the site adjoining the NECR siding yard is largely unpaved areas, with irregular topography.

The work currently proposed by the Connecticut Port Authority (CPA), known as the State Pier Infrastructure Improvements (SPII or the Project), is anticipated to occur in two phases. Phase One "Upland Area" will occur primarily within upland portions of the site and will include the following actions:

- Demolition of various buildings and roads and rails,
- Site grading and installation of stormwater collection and treatment systems,
- Installation of potable and fire suppression water systems,
- Installation of perimeter fencing and associated lighting and security systems,
- Installation of electrical infrastructure to meet site requirements,
- Installation of dense graded aggregate top surface,
- Demolition of existing pile supported platform at western end of Northeast Bulkhead (NE BH),
- Installation of anchored combination wall bulkhead directly outshore of existing NE BH,
- Installation of energy absorbing fenders and bollards at NE BH,
- Demolition of four existing mooring dolphins in Thames River, and
- Installation of steel sheet pile wall directly outshore of existing Northwest Bulkhead granite block retaining wall.

Phase Two, "Waterfront Works" will consist of water based work, accomplished either from onshore or from barges, depending on the location and requirements of the task. This work will occur outshore of the upland NE BH, bulkheads on the State and CVRR Piers and the area between these two piers and will consist of the following actions:

- Dredging at NE BH to accommodate import and installation vessels,
- Selective demolition of SW corner of State Pier and SE corner of CVRR pier to accommodate the king pile wall,

- Installation of anchored king pile combination bulkhead between State and CVRR Piers,
- Placement of seven acres of fill between the CVRR and State Piers to match elevation of State Pier,
- Raising elevation of remaining horizontal surface of the CVRR Pier to match that of the State Pier,
- Installation of dense graded aggregate top surface,
- Installation of energy absorbing fenders and bollards,
- Dredging to south of king pile wall between State and CVRR Piers for jack-up installation vessel, and
- Seabed preparation for jack-up installation vessel.

Upland Area construction is anticipated to start in November 2019, and Waterfront Works construction is anticipated to start in October 2020. The entire project is expected to be completed over a 3 year period and construction is anticipated to be finished by April 2022.

A request for a Natural Diversity Database (NDDDB) state-listed species review was initiated for the Project in January 2019. In a response dated March 19, 2019 (Attachment B), NDDDB indicated the Connecticut Department of Energy and Environmental Protection (CT DEEP) had records for the state-threatened Peregrine Falcon [*Falco peregrinus*] or (falcon)] nesting on the Gold Star Memorial Bridge. To protect nesting falcons, the CT DEEP recommended construction be completed outside of the nesting season from July 1 through March 31 and that no construction activities should occur during the nesting season between April 1 and June 30. In this same letter, CT DEEP indicated that if construction needs to be completed during the stated nesting period of April 1 through June 30, CPA should hire an ornithologist to evaluate proposed activities and prepare a Peregrine Falcon Protection Plan. CT DEEP has further directed that all work associated with the Project maintain a minimum buffer of 600' from an active falcon nest site and that should a falcon nest be observed proximal to active Project construction work, all work should cease and the nest site should be reported to CT DEEP/NDDDB for further assistance and guidance.

2.0 Peregrine Falcon Physical Description and Habitat

Weighing up to 3.5 pounds, measuring up to 20 inches in length and with a wingspan of up to 43 inches, the Peregrine Falcon is Connecticut's largest falcon species. Adults are slate blue/gray above and pale underneath with barred underparts and a dark head with thick sideburns. As with all falcons, peregrines exhibit long pointed wings and a long, rounded tail with narrow, black bands ending with a broad, dark band tipped with white narrow fringe. The feet are yellow.

Peregrine Falcons will utilize a wide variety of habitats, from open country, such as coastal lowlands, as well as along rivers, to highly developed urban locations. In Connecticut, this species has adapted to life in urban settings and often nests on manmade structures such as high rise buildings and bridges. Such structures provide protection from land-based predators and a vantage point from which to hunt for prey such as pigeons, waterfowl and other small to medium sized birds, while expending minimal energy.

2.1 Life History

Nest sites, known as eyries, are a hollow, unlined scrape on a cliff, ledge, or rocky outcrop. Abandoned raven or hawk nests in suitable locations are also occasionally used. The most publicized nesting areas have been on roofs and ledges of city buildings, as well as bridges. Pairs mate for life and may use the same nest site for many years. Male peregrines arrive at the nest site first (as early as February/March) to reestablish territories and to attract the females to the site utilizing aerial displays.

According to the CT DEEP, typically three to four cream or buff-colored eggs, covered with red-brown markings, are laid in late April and into May at intervals of two to three days. Incubation, primarily done by the female but with some help from the male, begins with the second or third egg and lasts 28 to 29 days for each egg. The hatchlings are closely brooded by the female for the first 14 days. The male typically brings food for all to the nest and the female feeds the young. The young begin to fledge at 35 to 42 days but remain dependent on the adults for another two months. For additional information on the species, please refer to the Peregrine Falcon Fact Sheet located in Attachment C.

3.0 Peregrine Falcon Protection Provisions

During the construction period for the Project, the following measures are proposed:

- Construction Phase Contractor Awareness Program;
- Construction Phase Survey and Monitoring Plan;
- Coordination with CT DEEP; and,
- Reporting.

The measures are described separately below.

3.1 Construction Phase Contractor Awareness Program

A contractor awareness program will be implemented to ensure all personnel working on the Project are aware of the potential presence of an active Peregrine Falcon nest site on or proximal to the site. As part of site specific training, all personnel will be given a copy of the Peregrine Falcon fact sheet, produced by the CT DEEP (Attachment C of this document) and will be directed to stop work if activity is occurring within 600 feet of any suspected falcon nest site. Construction personnel would be further instructed to notify CPA's on-site environmental personnel of the suspected observation. Work would not resume until a determination has been made by a qualified wildlife biologist/ornithologist regarding the reported observation.

3.2 Construction Phase Survey and Monitoring Plan

In all years with active construction scheduled to occur within the identified nesting period (April 1 through June 30), CPA will make reasonable efforts, through on-site surveys by a qualified wildlife biologist/ornithologist and in coordination with CT DEEP, to determine if falcons are nesting on or proximal to the site and/or within 600 feet of planned and/or active construction. For the purposes of this plan, "pass through" construction vehicle traffic shall not be considered active construction.

Peregrine Falcons nesting in urban settings and/or areas with significant human presence/activities have become habituated and acclimated to these disturbances. The exposure and habituation of the falcons nesting on the Gold Star Bridge to high levels of baseline noise consisting of I-95 vehicular traffic, periodic maintenance activities on the bridge, high noise levels associated with wind passing through and around the bridge, passage of trains on the adjacent active railroad track and vessel traffic on the Thames River below has likely resulted in a high disturbance threshold for the individuals nesting on the bridge. Additionally, the difference in elevation between a potential bridge nest site and the elevation of the work itself is significant, further reducing the potential impact of construction related noise disturbance.

Peregrine Falcon studies conducted for the Hudson River Crossing Project have determined that bridge nesting Peregrine Falcons have a very high tolerance of human disturbance and are not easily impacted by human activity, including construction activity associated with heavy equipment in a maritime environment (Attachment D). Behavioral observations of the resident Peregrine Falcons on the Tappan Zee Bridge crossing of the Hudson River, carried out before and during implementation of a Pile Installation Demonstration Program, determined there was no observable difference in falcon behavior as a result of construction activity and anecdotally, there was no evidence to suggest the breeding pair was in any way disturbed.

Therefore, in the event an active falcon nest is confirmed proximal to active construction, under the full time supervision of a qualified wildlife biologist/ornithologist, CPA proposes to allow construction activities to proceed to within 300 feet of any active Peregrine Falcon nest site. If it is determined by the biologist,

through observation of falcon behavior, that construction activity may be negatively impacting the birds in any way, the full 600 feet of buffer will automatically go into effect, with the previously noted exception of “pass through” construction vehicle traffic.

3.3 Coordination with CT DEEP

In the event that an active peregrine falcon nest site is discovered proximal to the Project, CPA will immediately contact the CT DEEP NDDDB Program. The NDDDB will be provided with relevant nest site details such as location, distance to active and/or proposed construction, observed falcon behavior/activity, and photographic evidence, if possible. CPA will coordinate closely with the CT DEEP in order to seek guidance to perform the work safely and specify monitoring requirements.

3.4 Reporting Requirements

Immediately after conducting daily falcon monitoring, the monitor shall complete a Daily Construction Monitoring Report (Attachment E). After completion, the report shall be placed in a designated area. All Daily Construction Monitoring Reports shall be compiled and included in a final Peregrine Falcon Monitoring Report and submitted to the CT DEEP/NDDDB before the end of the calendar year. Since CPA does not anticipate the need to handle falcons at any time, no Scientific Collection Permit is anticipated for the monitoring work.

Attachment A

State Pier Facility, Site Locus

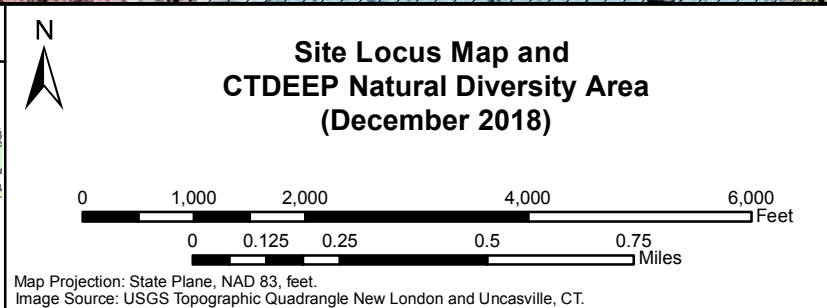
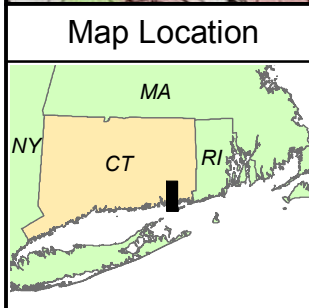
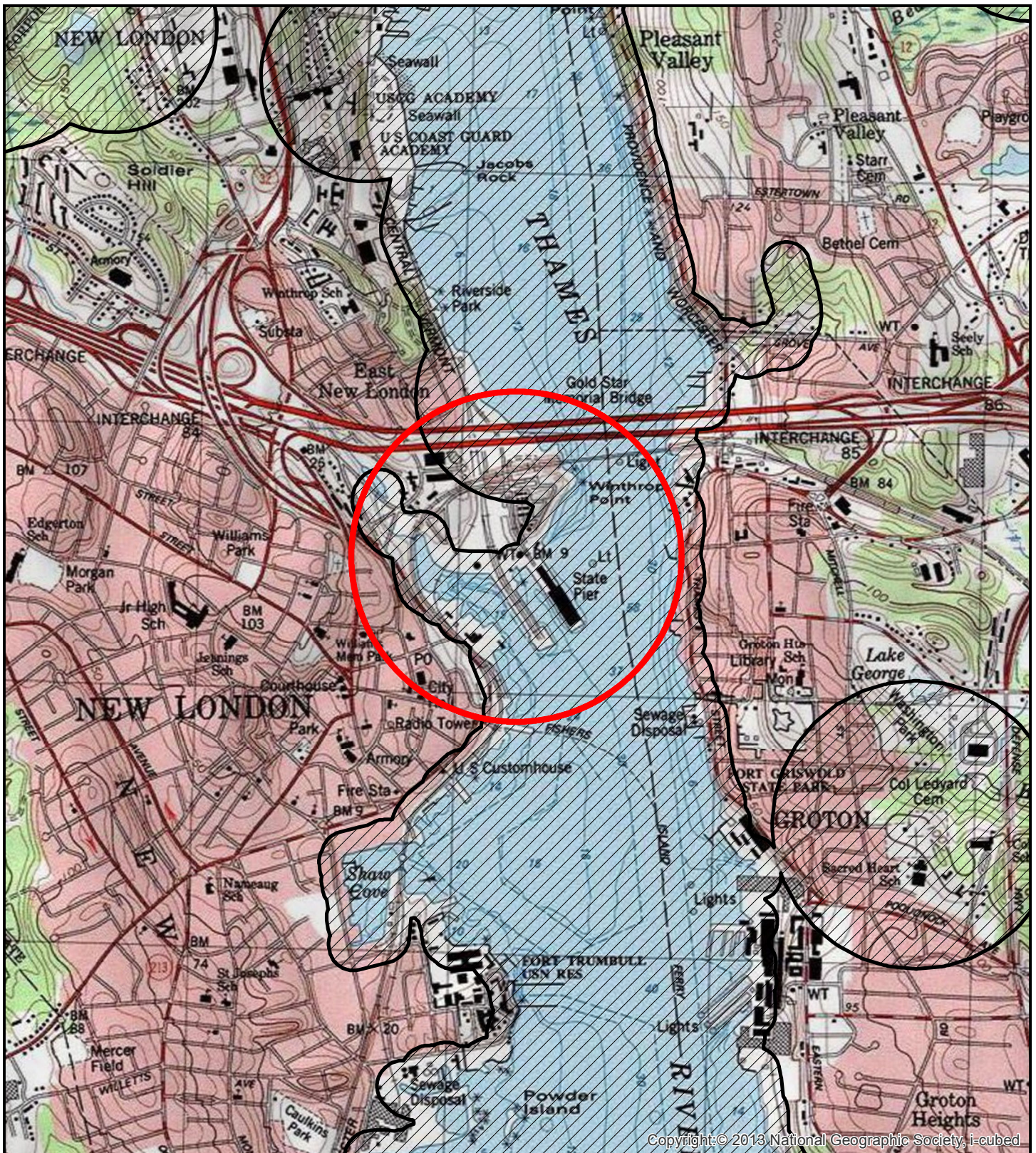

AECOM

Figure 1-1

3/6/2019

Proj. #: 60548556.3.3

Attachment B

CT DEEP/NDDDB March 19, 2019 Response Letter



Connecticut Department of
**ENERGY &
ENVIRONMENTAL
PROTECTION**

March 19, 2019

Richard E. Couch
Martinez Couch & Associates, LLC
1084 Cromwell Avenue
Rocky Hill, CT 06067
couchre@martinezcouch.com

Project: Proposed Demolition of Various Upland Buildings, Installation of New Structures Including Storm Water Retention & Treatment System, Addition of Administrative Offices with Parking and Maintenance Dredging at the State Pier at 200 State Pier Road in New London, Connecticut
NDDDB Determination No.: 201901490

Dear Richard Couch,

I have reviewed Natural Diversity Data Base maps and files regarding the area delineated on the map provided for the Proposed Demolition of Various Upland Buildings, Installation of New Structures Including Storm Water Retention & Treatment System, Addition of Administrative Offices with Parking and Maintenance Dredging at the State Pier at 200 State Pier Road in New London, Connecticut. We have known extant records for State Threatened *Falco Peregrinus* (peregrine falcon) and State Special Concern blueback herring that occur in close proximity to your project boundaries.

Please be advised that a DEEP Fisheries Biologist will review the permit applications you may submit to DEEP regulatory programs to determine if your project could adversely affect blueback herring. DEEP Fisheries Biologists are routinely involved in pre-application consultations with regulatory staff and applicants in order to identify potential fisheries issues and work with applicants to mitigate negative effects, including to endangered species. If you have not already talked with a Fisheries Biologist about your project, you may contact the Permit Analyst assigned to process your application for further information, including the contact information for the Fisheries Biologist assigned to review your application

Peregrine Falcon (*Falco peregrinus*) Protection Status: Threatened Species

The peregrine falcon is a state threatened species which has adapted to life in urban settings. The peregrine falcon is associated with bridges for nesting and brood rearing purposes. Peregrines will actively and aggressively defend the nest, whether a nest box or natural nest, up to and sometimes past 75 yards. The peregrine will attack anyone or anything that comes within the area of its nest. Peregrine falcons are Connecticut's largest falcon and can measure up to 20 inches. Adults are slate gray above and pale underneath with fine bars and spots of black; they

have long pointed wings with a narrow tail. Young falcons have the same composite but are darker underneath and browner all over. The peregrine falcon nesting season occurs between the months of April and June. For this reason, special conditions regarding the timing of work on the structure must be applied. In order to protect this species, the proposed construction activities should be completed during non-nesting season months (July – March). No construction activities should occur between April 1st and June 30th.

Protection Recommendation:

In order to protect this species, the proposed construction activities should be completed during non-nesting season months (July – March). No construction activities should occur between April 1st and June 30th. If work needs to be conducted during the breeding season (April 1st to June 30th) then I recommend hiring an ornithologist (bird expert) to evaluate and prepare a protection plan for the birds. All work on this project must maintain a minimum buffer of 600' from the nest. If a nest is identified by workers all work should stop immediately and this information should be reported to our program for further assistance and guidance to complete the work safely.

Please re-submit an NDDDB Request for Review if the scope of work changes or if work has not begun on this project by March 19, 2021.

Natural Diversity Data Base information includes all information regarding critical biological resources available to us at the time of the request. This information is a compilation of data collected over the years by the Department of Energy and Environmental Protection's Natural History Survey and cooperating units of DEEP, private conservation groups and the scientific community. This information is not necessarily the result of comprehensive or site-specific field investigations. Consultations with the Data Base should not be substitutes for on-site surveys required for environmental assessments. Current research projects and new contributors continue to identify additional populations of species and locations of habitats of concern, as well as, enhance existing data. Such new information is incorporated into the Data Base as it becomes available. The result of this review does not preclude the possibility that listed species may be encountered on site and that additional action may be necessary to remain in compliance with certain state permits.

Please contact me if you have further questions at (860) 424-3592, or dawn.mckay@ct.gov . Thank you for consulting the Natural Diversity Data Base.

Sincerely,

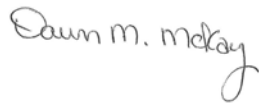

Dawn M. McKay
Environmental Analyst 3

Attachment C

Peregrine Falcon Fact Sheet

Connecticut Department of Energy & Environmental Protection

Peregrine Falcon

Falco peregrinus

State Threatened Species



Background: The peregrine falcon was a regular nester in Connecticut from the 1860s through the early 1900s. Prior to the Migratory Bird Treaty Act of 1918 and the strengthening of collection regulations, hundreds of peregrine eggs and many adult specimens were collected in Connecticut and Massachusetts. Some live birds and eggs were collected for use in falconry. Many more eggs and specimens were added to private collections as part of a popular late 19th century hobby. Peregrine nesting activity in Connecticut declined through the 1920s and 1930s, and the last documented nesting occurred on the Travelers Tower in Hartford in the late 1940s. Peregrines remained absent from Connecticut until 1997 when a pair successfully nested once again on the Travelers Tower. The peregrine falcon was listed in 1992 as an endangered species on Connecticut's Endangered Species List. It was reclassified as a threatened species in 2010.

Peregrine falcon populations declined rapidly between 1950 and 1965 throughout the United States and parts of Europe. By 1975, the entire population of peregrines in the eastern United States was considered to be extirpated (disappeared from that region). This decline is directly attributed to the effect of organochlorine pesticides, such as DDT, on breeding populations. The speed and global scale of this species' decline makes it one of the most remarkable events in recent environmental history.



Due to the population crash, the peregrine falcon was declared a federally endangered species, and extensive efforts were made to reestablish birds in the eastern United States. Successful reintroduction programs, using captive-bred birds, helped restore

small breeding populations along the East Coast. The Peregrine Fund, a non-profit organization dedicated to restoring peregrine populations, conducted the large captive breeding program. The reestablishment effort, coupled with restrictions placed on the use of organochlorine pesticides in the United States (DDT was banned in 1972), resulted in the recovery of the peregrine falcon population. The peregrine was removed from the federal endangered species list in 1999.

While Connecticut did not participate in any reintroduction programs, the state benefited from our neighboring states' efforts. In 1997, a peregrine pair successfully produced 3 chicks on the Travelers Tower. Leg bands revealed that the female of the pair had come from a 1994 reintroduction project in Greece, New York, sponsored by Rochester Gas & Electric, in cooperation with the New York Department of Environmental Conservation. In the years since peregrine falcons began nesting again in Connecticut, additional pairs have successfully produced young at locations in several towns. Every year, a number of dedicated volunteers and Wildlife Division staff monitor the nests throughout the nesting and fledging seasons. Division biologists also attempt to visit the nests (if they are accessible) to place identifying leg bands on the young before they fledge. This is an important management tool for monitoring this state threatened species.

Description: The peregrine falcon is a long-winged, medium-sized bird of prey. Adults have long, pointed wings and a long, rounded tail with narrow, black bands ending with a broad, dark band tipped with white. The barred upper parts are blue-gray, while the underparts are white to light buff and cross-banded with brown. The black crown and nape extend to the cheeks, forming a distinct black helmet. The feet are yellow.

Immature peregrines are similar, but the back and underparts are brown and the throat is heavily streaked with brown. Both adult and immature peregrines have a bold, dark, vertical whisker-like mark (mustache mark) on the sides of the head.

Range: The peregrine falcon is one of the most widespread birds in the world. It is found on all continents except Antarctica, and on many oceanic islands. Although widely distributed, the peregrine is common in only a few places.

Habitat and Diet: A wide variety of habitats are used by peregrine falcons. The birds are found in open country, such as coastal lowlands, as well as along rivers and in urban locations.

Pigeons, waterfowl, crows, jays, starlings, shorebirds, and other medium to small birds are the main prey items of the peregrine. In urban areas, pigeons and starlings comprise most of the diet. Beetles, dragonflies, and migrating monarch butterflies are eaten occasionally.

Life History: Nest sites, known as eyries, are located above an open area so the falcons can launch their aerodynamic hunts. The nest is a hollow, unlined scrape on a cliff, ledge, or rocky outcrop. Abandoned raven or hawk nests in similarly high locations are occasionally used. The most publicized nesting areas have been on roofs and ledges of city buildings. Pairs may use the same nest site for many years. Male peregrines arrive at the nest site first and go through a series



of aerial displays to attract the females to the site. Territories are usually reestablished by late March.

Three to 4 cream or buff-colored eggs, covered with red-brown markings, are laid in late April and May at intervals of 2 to 3 days. Incubation, primarily done by the female, begins with the second or third egg and lasts 28 to 29 days for each egg. The hatchlings are closely brooded by the female for the first 14 days. The male typically brings food for all to the nest and the female feeds the young. The young begin flying at 35 to 42 days but remain dependent on the adults for another 2 months.

Peregrine falcons reach sexual maturity at age 3, and they may reach 17-20 years of age.

Interesting Facts: The peregrine falcon is probably best known for its spectacular method of capturing prey in mid-air. It flies faster than most other birds and, when hunting, it increases its speed by making aerial dives with the wings partially or fully pulled in. The peregrine plunges at speeds up to 175 miles per hour (mph) to attack its prey, which is killed instantly. This hunting dive is called a "stoop." Normal flight speed can range between 28 to 60 mph.

Because of its habit of preying on waterfowl, the peregrine falcon has historically been referred to as the duck hawk.

Peregrines can be preyed upon by great horned owls, gyrfalcons, and other peregrines.

Peregrine falcons have adapted to living in cities. Cities offer tall buildings with ledges for nesting, water sources, large populations of pigeons and starlings for food, and have few natural predators.

The scientific name comes from the Latin words *falco*, meaning "hook-shaped," possibly referring to the beak or claws, and *peregrinus*, meaning "to wander."

As part of the reintroduction effort, The Peregrine Fund released more than 4,000 captive-reared peregrines in 28 states over a 25-year period.

What You Can Do: Respect locations of peregrine nest sites and do not disturb nesting birds.

North American peregrine falcon populations continue to be threatened by the use of DDT in the tropics where some spend the winter. Support for the advancement of alternative methods of pest control in developing nations will help not only the peregrine, but ospreys and countless species of songbirds that nest in the United States and Canada and winter in Central and South America.



The production of this Endangered and Threatened Species Fact Sheet Series is made possible by donations to the [Endangered Species/Wildlife Income Tax Checkoff Fund](#).

Content last updated on March 27, 2012.

Attachment D

Peregrine Falcon Monitoring Report, Hudson River Crossing Project

Tappan Zee Hudson River Crossing Project Peregrine Falcon Monitoring Report

JUNE 2012

1-1 EXECUTIVE SUMMARY

A monitoring plan approved by the New York State Department of Environmental Conservation (NYSDEC) was implemented to document any disturbance from the Pile Installation and Demonstration Program (PIDP) to the resident pair of peregrine falcons on the Tappan Zee Hudson River Crossing. Scan sampling was used to measure and compare peregrine falcon time budgets before and during a range of PIDP activities that were categorized by their expected potential to cause disturbance. Low disturbance activities included preliminary set-up work, such as towing cranes and other heavy equipment to the test pile locations, assembling vibration and impact hammers, installing bubble curtains, and similar in-water actions leading up to the driving of test piles. Activities of moderate disturbance potential included the construction of falsework and framing (temporary wooden or metal framework built to support a structure under construction) and the vibration of lower pile segments. Impact hammering, which was the loudest PIDP activity, was categorized as having high potential for disturbance. A total of 45 hours of observation on 15 separate days provided no indication that the birds' behavior was altered by the PIDP activities occurring at the time. The falcons were most often observed perched, and usually in the same distinct locations, independent of the PIDP work simultaneously occurring in the river below. There was no observation of any PIDP activity, including impact hammering, causing the birds to flush or otherwise respond. The birds were observed engaging in typical behaviors such as sharing food, provisioning young, and preening, which also suggests the birds were not in duress. The exposure and habituation of the peregrine falcons to extensive baseline levels of noise and other activity on the bridge under normal conditions has likely led to a high disturbance threshold in these individuals, possibly explaining why they did not appear to have any negative reaction to the PIDP. Further, the high noise levels on the bridge from traffic, maintenance operations, and wind likely masked much of the noise produced by PIDP work in the river below, including impact hammering. Impact hammering could not be heard by the peregrine falcon monitors from the observation point on the main span, and it is possible the impact hammering was inaudible to the birds as well. Bridge-nesting peregrine falcons inherently have a high tolerance of human disturbances, and on the basis of the monitoring summarized in this report, the resident pair on the Tappan Zee Hudson River Crossing does not appear to be sensitive to in-water construction activities such as those undertaken for the PIDP.

1-2 INTRODUCTION

Behavioral observations of the Tappan Zee Hudson River Crossing's resident pair of peregrine falcons were made before and during the Pile Installation Demonstration Program (PIDP) to investigate potential disturbance caused by the in-water construction

activity. The methodology and schedule for the peregrine falcon monitoring were reviewed and approved by NYSDEC in advance. The PIDP took place at four locations within the river, referred to as PLT1-PLT4, during the spring of 2012. A total of seven test piles were driven among these four locations (two piles in each of three locations and one pile in the fourth location). PLT1 and PLT2 were located within the Rockland County side of the project area, well west of the peregrine falcon nest box on the existing bridge's main span, whereas PLT3 and PLT4 were in closer proximity to the nest box location on the Westchester County side of the project area (**Figure 1**).

Initial site preparation included activities such as towing cranes and other heavy equipment to the test pile locations, assembling vibration and impact hammers, installing bubble curtains, and similar in-water actions leading up to the driving of test piles. Subsequent work included the installation of falsework piles (ancillary piles to support load frames) and framing (temporary wooden or metal framework built to support a structure under construction). Next, a low-noise, vibratory hammer was used to install the lower segment of each test pile. The upper segment was welded to the bottom segment, and then driven deeper into the riverbed by hydraulic impact hammering. Peregrine falcon monitoring spanned the range of these different PIDP activities, and included pre-PIDP observations as well as observations after all test piles had been installed. This report quantifies and compares the peregrine falcon behaviors observed during these periods.

1-3 METHODS

Observations were made from a closed lane on the bridge's main span road deck, which offered the best accessible vantage point. Lane closure schedules, however, greatly constrained the dates and times during which monitoring could occur. Generally, peregrine falcon monitoring was limited to weekdays, between approximately 9:30am and 12:00pm. For this reason, the peregrine falcons could not be comprehensively monitored throughout the full range of PIDP activities. However, dates and times of peregrine falcon monitoring were able to coincide with pile driving and other significant PIDP activities on at least one occasion. Observation dates and times, and the corresponding PIDP activities, are shown in **Table 1**.

Behavioral data were collected using an instantaneous scan sampling method (Gaibani and Csermely 2007), whereby the location and behavior of the birds were recorded at five minute intervals during the observation period and coded according to the ethogram in **Table 2** (adapted from Walter 1983). The sex of the birds could not be directly determined because peregrine falcons are not sexually dimorphic, aside from subtle differences in body size. Birds were seldom in close enough proximity to each other for size differences to be apparent. Instead, sex was presumed on the basis of the birds' behavior and all behavioral data are herein analyzed as such. For example, one bird often remained perched in front of the nest while the other bird flew long distances up- or down-river, or was otherwise out of view for extended periods of time. The bird that remained near the nest box was presumed to be female and the bird that would be absent for long periods was presumed to be male. Similarly, one bird often remained in (or near) the nest box while the other was perched on the top of the main span's north tower. The former was presumed to be female and the latter was presumed to be male. Even though male peregrine falcons contribute to incubation and nest attendance, the female performs these duties the majority of the time (White et al. 2002).

Often the birds (particularly the male) were not observable due to the limited range of visibility from the road deck. The male frequently perched somewhere out of view on or below the bridge, and often flew long distances down-river from the bridge until it could no longer be seen. Consequently, bird behaviors often had to be recorded as “unknown” during scan sampling. Also, the inside of the nest box could not be seen from the observation point, and a bird was only recorded as being inside the nest box if it had been seen entering or exiting the box at some point during the observation period.

Table #1
Peregrine Falcon Monitoring Schedule

Date	Monitoring time (EST)	Major PIDP activity	Location	Estimated breeding stage
5-Mar	10:00-11:40	None	N/A	Courtship
7-Mar	9:45-11:55	None	N/A	Courtship
8-Mar	10:10-12:10	None	N/A	Courtship
13-Mar	9:55-13:55	Equipment set-up	N/A	Courtship
19-Mar	9:50-11:50	Falsework / framing	PLT2	Courtship
2-Apr*	9:30-11:00	Falsework / framing	PLT3	Incubation
24-Apr	9:40-11:40	Equipment set-up	PLT4	Incubation
25-Apr	10:35-12:35	Equipment set-up	PLT3	Incubation
26-Apr	9:50-13:50	Equipment set-up	PLT3	Incubation
7-May	9:30-14:30	None- postponed	N/A	Chick rearing
8-May	9:35-12:45	Impact	PLT3	Chick rearing
14-May	10:00-13:00	Impact	PLT4	Chick rearing
16-May*	11:05-13:25	Impact*	PLT2	Chick rearing
18-May	9:40-13:20	Vibration & impact**	PLT3	Chick rearing
30-May	9:30-11:30	None***	N/A	Chick rearing

Notes:

*No birds were seen during Apr 2 and May 16 monitoring.

**Impact hammering occurred after the monitoring period ended.

***Re-driving of piles 2A and 2B occurred over a span of approximately 8 minutes at 9:00; otherwise no major PIDP activity with potential to disturb the peregrine falcons occurred. The May 30 monitoring period is therefore considered a post-impact-hammering follow-up visit.

Table #2		
Peregrine Falcon Ethogram¹		
Behavioral Classification	Identification	Defining Action
Physical Status	P1	perched
	P2	in flight, but not in pursuit of prey or sexual display
	P3	lying down
	P4	hopping, walking
	P5	other
Feeding and Body Care	F1	feeding self
	F2	drinking
	F3	asleep
	F4	panting
	F5	preening, cleaning
	F6	scratching
	F7	shaking feathers, sunning
	F8	pellet extraction/defecating
	F9	other
Hunting	H1	prey chase, pursuit , stoop flight
	H2	prey capture, in possession of prey
	H3	prey transport
	H4	other
Agnostic Behavior and Human Impact	A1	physically harassing, attacking bird or other animal
	A2	physically harassing, attacking human
	A3	threat display towards animal (e.g., gaping, wings open)
	A4	threat display towards human
	A5	fleeing from human disturbance
	A6	other
Sexual Behavior	S1	display from perch (e.g., bowing)
	S2	aerial display
	S3	allopreening, billing, other contact
	S4	offering food
	S5	receiving food
	S6	copulation
	S7	other
Nest-Related Behavior	N1	inside nest box
	N2	feeding young
Vocalization	V1	vocalizing directed at mate
	V2	vocalizing at other conspecific
	V3	undirected vocalization
	V4	other
	-	(threat vocalization under a3 and a4)
Notes: ¹ a descriptive list of the known behaviors of a given species that is used to study animal behavior.		

The behavioral data collected from instantaneous scan sampling were used to calculate time budgets of the birds (i.e., proportion of the observation time that birds were

engaged in a given behavior). Time budgets were then compared among different phases of the PIDP that were categorized by their expected potential to cause disturbance to peregrine falcons (**Figure 2**). “No disturbance” periods include the pre-PIDP monitoring conducted on March 5, 7, and 8, and monitoring conducted on May 7 when equipment failure caused a suspension of the scheduled work. “Low disturbance potential” events include heavy equipment mobilization, set-up, and assembly at test pile locations during monitoring periods on March 13, April 24, 25, 26, and May 16. “Moderate disturbance potential” periods include the falsework and framing work performed on March 19 and the vibration hammering on May 18. “High disturbance potential” includes impact hammering on May 8 (at PLT3, the closest test location to the falcons’ nest site). On May 14, impact hammering (at PLT4) began prior to the morning lane closure and was completed approximately 0.5 hr after peregrine falcon monitoring was able to begin. Observation data collected during the 0.5 hr overlap of impact hammering at PLT4 and peregrine falcon monitoring were included in the analysis of “high disturbance potential” data. Observation data from the hour after impact hammering on May 14 had ended were also included to capture the birds’ behavior following the potential disturbance of impact hammering. All other impact hammering occurred on dates and at times when no lane was closed on the bridge and peregrine falcon monitoring was not feasible.

No birds were seen during the peregrine falcon monitoring conducted on April 2, and on May 16, only one bird was observed briefly (flying east from the bridge). On March 5 and May 18, only the female was seen. Overall, the male was not seen nearly as often as the female, and as such, sample sizes of behavioral data for the male are small.

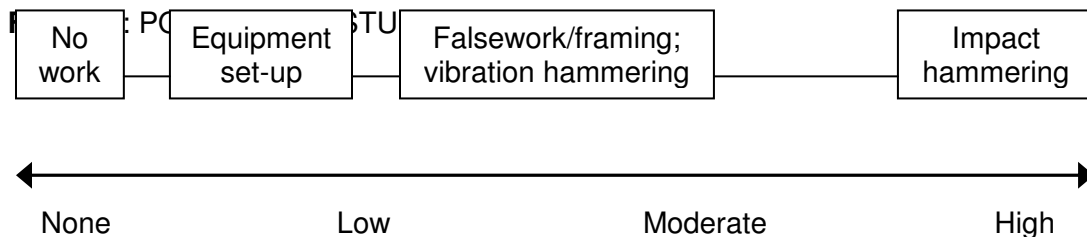

PIDP work activities were categorized by their expected potential to cause disturbance to peregrine falcons. “Equipment set-up” included activities such as towing cranes and other heavy equipment to the test pile locations, assembling vibration and impact hammers, installing bubble curtains, and similar in-water actions leading up to the driving of test piles that were considered to have low potential to cause disturbance. Constructing falsework and framing, and vibrating lower pile segments were considered to have moderate potential to disturb peregrine falcons. Impact hammering was the loudest PIDP activity and considered to have the highest potential to cause disturbance.

1-4 RESULTS

Peregrine falcon monitoring was conducted for a total of approximately 45 hours over 15 different days. Behaviors of the female that were recorded by scan sampling included perching, nest attendance, receiving food, and feeding young (i.e., entering the next box with food at a time when the nest was expected to contain nestlings). Male

behaviors included perching, nest attendance, flying, offering food, and preening (**Table 3**).

In March and April, prior to egg laying, one bird (presumably female) would often be seen for the majority of the monitoring period, usually near the nest box, whereas the other bird (presumably male) would only be seen intermittently and would be absent for extended periods of time. Later in the season, when the pair was expected to have eggs, the presumed female was often in the nest box while the presumed male was often either perched on the top of the main span's north tower or was out of view for long periods of time.

As discussed above, monitoring effort differed among different phases of the PIDP and often could not be conducted during primary PIDP activities because of lane closure schedules, construction delays, and other logistical constraints. Further, birds were often unseen during the monitoring periods and their behavior could not be recorded. Sample sizes of behavioral data were particularly small for the male. Because of these disparities, the unevenness of the monitoring effort across PIDP phases, and the small sample sizes, data were not analyzed statistically. Qualitatively, there were no noticeable trends in the birds' behaviors during phases of the PIDP with different expected levels of potential disturbance (**Table 3**). Time budgets in the days preceding initiation of the PIDP were similar to those measured during the PIDP, including periods of impact hammering. Anecdotally, there was also no evidence to suggest that the peregrine falcons were in any way disturbed by the PIDP.

Table #3								
Time budgets (expressed as percentages) of peregrine falcons on the Tappan Zee Hudson River Crossing before and during PIDP stages categorized by their potential to cause disturbance								
Expected Disturbance Level	Number*	Behavior (% of scan samples)						
		Perched	In Nest Box	In Flight	Offering Food	Receiving Food	Feeding Young	Preening
Female								
None	108	19	79				2	
Low	124	20	78			2		
Medium	38	97	3					
High	47	11	87			2		
Follow-up**	24	100						
Male								
None	22	86	9	5				
Low	19	68	5	16				11
Medium	17	94		6				
High	3	1 of 3		1 of 3	1 of 3			
Follow-up**	14	86						14
Notes: See Table 1 and Figure 1 for corresponding dates and PIDP activities.								
*Number of scan samples during which the bird was seen and behavior could be determined.								
**Follow-up monitoring on May 30 after driving of all test piles had concluded.								

1-5 DISCUSSION

In New York City and many other metropolitan areas, peregrine falcons nest on bridges, high-rise buildings, and other tall artificial structures amidst the high levels of noise and human activity associated with an urban environment, thus demonstrating a high tolerance of disturbance and an ability to exploit resources in human-dominated landscapes (Cade et al. 1996, White et al. 2002). Peregrine falcons began nesting on the Tappan Zee Bridge in the 1980's (Mildner 1988, Frank 1994) and continue to do so to this day.

Existing conditions for peregrine falcons nesting on the Tappan Zee Bridge are characterized by consistent and extensive levels of human activity. Vehicular traffic and strong winds create a remarkably noisy environment. The resident pair of peregrine falcons' selection of the nest site inherently indicates a tolerance of these conditions, and based on the direct observations of the birds throughout the monitoring program, it is apparent that the birds are indifferent to the human activity around them. In addition to the high traffic volume passing below their nest site, painters and other bridge maintenance/repair crews were highly active in close proximity to the nest location throughout the monitoring period. At no point did the birds appear to react to the crews or work vehicles operating below them.

A comparison of the peregrine falcons' time budgets before and during PIDP activities indicates that the birds' behavior was unaffected. Birds were most often observed perched, and usually in the same distinct locations, independent of the concomitant PIDP work occurring in the river below. The presumed female was almost always inside the nest box or perched on the supporting cross beam within approximately 20 feet of the nest. The male most commonly perched on the top of the main span's north tower, over the southbound traffic lanes. For both sexes, the proportion of time perched was comparable between the periods with no in-water work and the PIDP activities that ranged from low to high disturbance potential. There was no indication that any PIDP activity, including impact hammering, caused the birds to flush or otherwise respond. The birds engaged in other typical behaviors during the PIDP as well, including sharing food, provisioning young, and preening, which also suggests the birds were not in duress. On May 8, the female remained inside the nest box throughout the impact hammering of test pile 3A (the closest test pile location to the nest) that occurred from 10:05am to 11:30am. Birds usually flush from their nest when approached or otherwise disturbed. At no point did the female peregrine falcon appear to flush from the nest box or otherwise flee the area in panic flight.

The exposure and habituation of the peregrine falcons to the extensive baseline levels of noise and other activity on the bridge has likely led to a high disturbance threshold in these individuals and likely explains why they did not appear to have any negative reaction to the PIDP. Further, the high noise levels on the bridge from traffic, maintenance operations, and wind likely masked the majority of the noise produced by the PIDP work in the river below, including impact hammering. Neither of the two peregrine falcon monitors that were on the bridge on May 8 and 14 heard the impact hammering of test piles 3A and 4A that took place during the monitoring period. Both monitors were unaware that the impact hammering had occurred until they were later informed by the engineer in charge. The impact hammering (and other PIDP activities) may have been inaudible to the peregrine falcons above the high ambient noise levels around their nest site and other areas of frequent occurrence on the bridge.

In conclusion, 45 hours of observations provided no evidence that peregrine falcons nesting on the Tappan Zee Hudson River Crossing were affected by the PIDP, including the impact hammering of test piles in close proximity to the nest site. No signs of disturbance or altered behavior, such as avoidance of the nest site, repeated displacement from typical areas of occurrence, threat displays (erect feathers on head, back, and/or breast), or open-mouth breathing, were observed. The birds, particularly the female, continued to engage in typical behaviors throughout the various stages of in-water activity. Nest attendance did not appear to be altered in any way. As impact hammering of test pile 4A was in progress relatively close to the nest, the male was observed delivering prey to the female at the nest, which suggests both birds were indifferent to any noise or visual disturbance generated by the pile driving. These overall findings are consistent with observations of peregrine falcons successfully nesting on the San Francisco-Oakland Bay Bridge during the bridge's earthquake retrofitting project in the early 2000's and the current, ongoing construction of its replacement bridge (Stewart 2011). Bridge-nesting peregrine falcons inherently have a high tolerance of human disturbances, and on the basis of the monitoring summarized in this report, the resident pair on the Tappan Zee Hudson River Crossing is not sensitive to in-water construction activities such as those undertaken for the PIDP. Similarly, future construction of a replacement bridge is not expected to cause nest-site abandonment or otherwise negatively impact peregrine falcons nesting on the existing bridge.

1-6 REFERENCES

- Cade, T.J, M. Martell, P. Redig, G. Septon, and H. Tordoff. 1996. Peregrine falcons in urban North America. In: D.M. Bird, D. Varland, and J. Negro (eds.) Raptors in human landscapes: adaptations to built and cultivated environments. Academic Press, San Diego, CA.
- Frank, S. 1994. City peregrines: a ten-year saga of New York City falcons. Hancock House, Blaine, WA.
- Gaibani, G. and D. Csermely. 2007. Behavioral studies. In: D.M. Bird, K.L. Bildstein, D.R. Barber, and A. Zimmerman (eds.). Raptor research and management techniques. Hancock House, Surrey, B.C., Canada.
- Mildner, D. 1988. An active peregrine eyrie along the Hudson. *Kingbird* 38: 246-247.
- Stewart, G.R. 2011. Personal communication between Glenn R. Stewart, Santa Cruz Predatory Bird Research Group and Chad L. Seewagen, AKRF Inc., November 18 and 21, 2011.
- Walter, H. 1983. The raptor actigram: a general alphanumeric notation for raptor field data. *Raptor Research* 17:1-8.
- White, C.M., N.J. Clum, T.J. Cade, and W.G. Hunt. 2002. Peregrine Falcon (*Falco peregrinus*). In: A. Poole and F. Gill (eds.) *The Birds of North America*, No. 660. The Birds of North America, Inc., Philadelphia, PA.

Attachment E

Construction Monitoring Report Form

DAILY CONSTRUCTION MONITORING REPORT

**State Pier Infrastructure Improvements
New London, CT**

Project Number: _____

Project Manager:

Date:

On-Site personnel:

WEATHER CONDITIONS:

WORK COMPLETED:

OBSERVATIONS / RECOMMENDATIONS:

SAFETY ISSUES:

OTHER COMMENTS:

STATE PIER INFRASTRUCTURE IMPROVEMENTS

STATE PIER FACILITY

NEW LONDON, CONNECTICUT

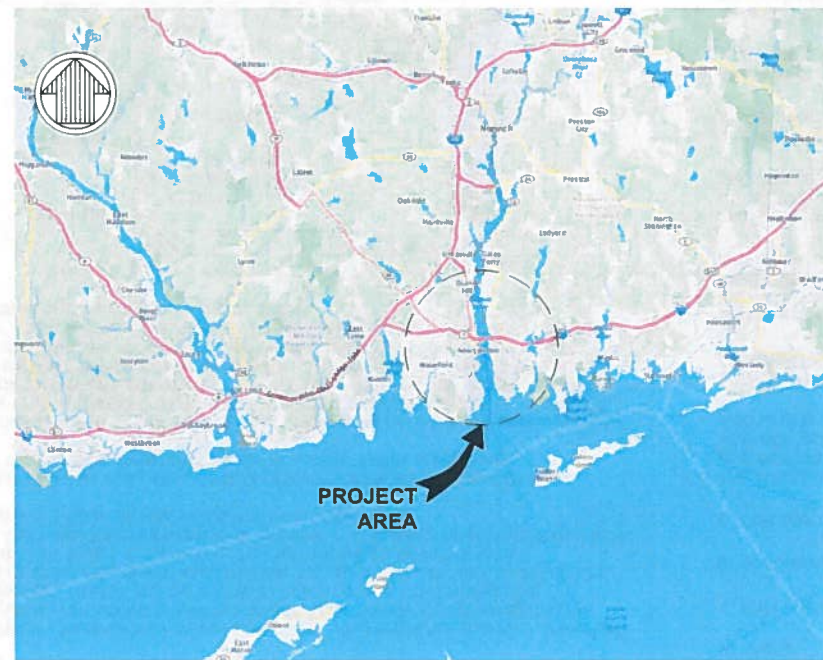

AREA MAP



LOCATION MAP

DRAWING INDEX	
SHEET NUMBER	SHEET TITLE
1	COVER SHEET
2	NOTES - 1 OF 2
3	NOTES - 2 OF 2
4	EROSION AND SEDIMENT CONTROL NOTES - 1 OF 3
5	EROSION AND SEDIMENT CONTROL NOTES - 2 OF 3
6	EROSION AND SEDIMENT CONTROL NOTES - 3 OF 3
7	EROSION AND SEDIMENT CONTROL PLAN
8	EXISTING TOPOGRAPHIC AND HYDROGRAPHIC PLAN
9	EXISTING CONDITIONS PLAN
10	DEMOLITION AND REMOVAL PLAN
11	EXISTING STATE PIER PILE SUPPORTED PLATFORM
12	PROPOSED PLAN
13	PROPOSED DREDGING PLAN
14	GRADING AND DRAINAGE PLAN
15	PHASING PLAN
16	WORK COVERED UNDER CERTIFICATE OF PERMISSION AND CT GP PERMITS
17	OFFICE AND PARKING PLAN
18	FACILITY USE AND LOGISTICS PLAN
19	FEDERAL CHANNEL MAP PLAN
20	INSTALL VESSEL NAVIGATION PLAN (INBOUND)
21	INSTALL VESSEL NAVIGATION PLAN (OUTBOUND)
22	NORTHEAST BULKHEAD SECTIONS
23	PROPOSED EAST STATE PIER PILE SUPPORTED PLATFORM
24	KING PILE WALL CLOSURE BETWEEN CVRR AND STATE PIER
25	CVRR BULKHEAD SECTIONS
26	MOORING PLATFORM SECTION
27	BUOY ANCHORAGE AND MOORING DOLPHIN DETAILS
28	DRAINAGE STRUCTURE DETAILS - 1 OF 2
29	DRAINAGE STRUCTURE DETAILS - 2 OF 2
30	OUTFALL DETAILS
31	DUCTBANK DETAILS
32	PROPOSED DREDGE ALIGNMENT PLAN
33	NORTHEAST BERTH DREDGE SECTIONS
34	EAST BERTH DREDGE SECTIONS
35	DREDGE SECTIONS FOR INSTALL VESSEL JACK-UP LEGS

DWG INFO: C:\BOS\Projects\1630\Detail Design\State pier\500 CAD\DWG\PermitSet\1630-01.dwg; May 4, 2020 - 8:04 PM; CMOYANGLASIAS; C:\MOFFATT AND NICHOL



PERMITTING SET
ISSUED: 10/23/2020
NOT TO BE USED FOR CONSTRUCTION



Digitally signed by
Eric D Smith
DN: c=US,
o=Unaffiliated,
ou=A01410C000001
71CC9B22C1000099
D6, cn=Eric D Smith
Date: 2020.10.27
09:15:40 -04'00'

GENERAL NOTES

1. ALL FEDERAL, STATE, AND LOCAL SAFETY REGULATIONS ARE TO BE STRICTLY FOLLOWED.
2. THE CONTRACTOR SHALL ABIDE BY ALL APPLICABLE FEDERAL, STATE, AND LOCAL ENVIRONMENTAL PROTECTION STANDARDS, LAWS AND REGULATIONS.
3. THE CONTRACTOR SHALL BE RESPONSIBLE FOR THE MAINTENANCE OF THE CONSTRUCTION SITE AND THE AREAS OF WORK WHILE PERFORMING THE WORK OF THIS CONTRACT. CONSTRUCTION DEBRIS SHALL BE REMOVED FROM THE CONSTRUCTION SITE ON A DAILY BASIS. NO BURNING OF DEBRIS SHALL BE PERMITTED.
4. DURING ALL PHASES OF THE WORK ALL PRECAUTIONS SHALL BE TAKEN AS NECESSARY OR AS REQUIRED TO PERMANENTLY PREVENT CONTAMINATED WATER, VEHICLE FLUIDS, CONSTRUCTION DEBRIS, AND ANY OTHER CONTAMINANT FROM ENTERING THE WATERWAY.
5. CONTRACTOR SHALL INSTALL A FLOATING BOOM SYSTEM THAT FULLY ENCLOSES THE WORK AREA. THIS BOOM SHALL BE ANCHORED IN PLACE OR ATTACHED TO A FIXED STRUCTURE. THIS BOOM SHALL BE CAPABLE OF COLLECTING ANY FLOATING DEBRIS GENERATED DURING CONSTRUCTION ACTIVITIES. DEBRIS SHALL BE COLLECTED AND DISPOSED OF FROM THIS BOOM ON A DAILY BASIS.

TURBIDITY CURTAIN:

1. A FLOATING TURBIDITY BARRIER MAY BE DEPLOYED AROUND AND/OR IMMEDIATELY ADJACENT TO THE WORK AREA AS SHOWN ON SHEET 11 DURING EACH CONSTRUCTION PHASE THAT IS EXPECTED TO PRODUCE DEBRIS AND/OR SEDIMENT IN 600 FOOT (MAX) LENGTHS. THE CONTRACTOR IS RESPONSIBLE FOR STAYING UNDER THE TURBIDITY LIMIT SET BY THE STATE. DURING ALL PHASES OF WORK, THE CONTRACTOR MAY PROPOSE AN ALTERNATIVE METHODOLOGY AND SUBMIT TO THE STATE FOR APPROVAL. ALTERNATIVE METHODOLOGY MUST BE SUBMITTED 45 DAYS PRIOR TO FILL PLACEMENT BETWEEN PIERS.
2. TURBIDITY CURTAIN WILL BE AVAILABLE ON-SITE FOR USE AS WARRANTED BASED ON MONITORING OF TURBIDITY TO MAINTAIN COMPLIANCE WITH PERMIT CONDITIONS.
3. TO SERVE AS A BARRIER FOR OPERATIONS DURING PLACEMENT BETWEEN THE PIERS, A HEAVY DUTY TYPE III OR TYPE IV TURBIDITY CURTAIN WITH A BOTTOM ANCHOR SHALL BE INSTALLED. THE CONTRACTOR MAY UTILIZE EQUIPMENT TO LEVEL THE RIVER BOTTOM TO IMPROVE THE FUNCTIONALITY OF THE TURBIDITY CURTAIN AND MAY UTILIZE PILES OR OTHER ANCHORS TO KEEP THE TURBIDITY CURTAIN IN PLACE DURING OPERATIONS. THE CONTRACTOR SHALL PERFORM DAILY VISUAL INSPECTIONS, WITH A PHYSICAL CHECK ON THE TURBIDITY CURTAIN WITHIN 24 HOURS OF ANY MAJOR STORM OR ICE EVENT.

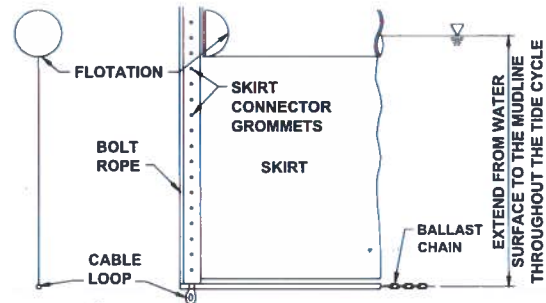

NOTES:

1. FIGURE IS FOR REFERENCE ONLY. TURBIDITY CURTAIN SHALL BE SUBMITTED BY THE CONTRACTOR FOR APPROVAL.
2. CURTAIN ANCHORAGE TO STRUCTURE AND MUDLINE SHALL BE SUBMITTED BY THE CONTRACTOR.

TURBIDITY CURTAIN

EROSION AND SEDIMENT CONTROL NOTES

GENERAL EROSION CONTROL NOTES

1. SOIL EROSION AND SEDIMENTATION CONTROL MEASURES SHALL BE IN CONFORMANCE WITH THE CONNECTICUT DEPARTMENT OF ENERGY AND ENVIRONMENTAL PROTECTION (CT DEEP) "2002 CONNECTICUT GUIDELINES FOR SOIL EROSION AND SEDIMENTATION CONTROL" DEEP BULLETIN NO. 34, LATEST REVISION, AND THE CONNECTICUT DEPARTMENT OF TRANSPORTATION (CTDOT) "2004 CONNECTICUT STORM WATER QUALITY MANUAL", LATEST REVISION, AND THE CTDOT FORM 817.
2. INSTALL ALL EROSION CONTROL MEASURES SHOWN, SPECIFIED OR REQUIRED BY THE ENGINEER PRIOR TO ANY CONSTRUCTION MEASURES UNTIL FINAL SURFACE TREATMENTS ARE IN PLACE AND/OR UNTIL ALL PERMANENT VEGETATION IS ESTABLISHED.
3. MARK WORK LIMIT LINE(S) PRIOR TO STARTING WORK. DO NOT DISTURB VEGETATION OR TOPSOIL BEYOND THE PROPOSED LIMIT LINE. COORDINATE WITH THE ENGINEER FOR THE LOCATIONS FOR THE TEMPORARY STOCKPILING OF TOPSOIL DURING CONSTRUCTION.

4. FINE GRADE AND IMMEDIATELY SEED ALL SIDE SLOPES, SHOULDER AREAS, AND DISTURBED VEGETATED AREAS. ALL GRADING TO BE A MAXIMUM SLOPE OF 2:1, COMPACTED, AND STABILIZED. SLOPES GREATER THAN 2:1 TO RECEIVE EROSION CONTROL BLANKET.
5. REMOVE ALL SEDIMENT TRACKED ON PUBLIC RIGHT-OF-WAYS AT THE END OF EACH DAY.
6. LAND DISTURBANCE SHALL BE KEPT TO A MINIMUM NECESSARY FOR CONSTRUCTION.
7. ALL CATCH BASINS SHALL BE PROTECTED WITH SILT SACKS, HAY BALE RINGS, OR SILT FENCE THROUGHOUT THE CONSTRUCTION PERIOD AND UNTIL ALL DISTURBED AREAS ARE THOROUGHLY STABILIZED.
8. WHENEVER POSSIBLE, EROSION AND SEDIMENTATION CONTROL MEASURES SHALL BE INSTALLED PRIOR TO CONSTRUCTION, ADDITIONAL CONTROL MEASURES SHALL BE INSTALLED DURING CONSTRUCTION.
9. THE CONTRACTOR SHALL USE APPROVED METHODS/MATERIALS FOR PREVENTING THE BLOWING AND MOVEMENT OF DUST FROM EXPOSED SOIL SURFACES ONTO ADJACENT PROPERTIES AND SITE AREAS.
10. AFTER CONSTRUCTION, EROSION AND SEDIMENTATION WITHIN PROJECT LIMITS WILL BE MANAGED BY FINISHED TERMINAL SURFACE.
11. MINIMIZING WIND EROSION AND CONTROLLING DUST WILL BE ACCOMPLISHED BY ONE OR MORE OF THE FOLLOWING METHODS:
 - A. COVERING 30% OR MORE OF THE SOIL SURFACE WITH NON-ERODIBLE MATERIAL.
 - B. ROUGHENING THE SOIL TO PRODUCE RIDGES PERPENDICULAR TO THE PREVAILING WIND.
 - C. FREQUENT WATERING OF EXCAVATION AND FILL AREAS.
12. THE CONSTRUCTION ENTRANCE SHALL BE MAINTAINED IN A CONDITION WHICH WILL PREVENT TRACK OR FLOW OF MUD ONTO PUBLIC RIGHT-OF-WAY. THIS MAY REQUIRE PERIODIC TOP DRESSING WITH 1-3" OF STONE, AS CONDITIONS DEMAND. ALL MATERIALS SPILLED, DROPPED, WASHED, OR TRACKED FROM VEHICLE ONTO PUBLIC ROADWAY OR INTO STORM DRAIN MUST BE REMOVED IMMEDIATELY.
13. CONTRACTOR SHALL INSPECT CONTROL MEASURES AT THE END OF EACH WORKING DAY TO ENSURE MEASURES ARE FUNCTIONING PROPERLY.
14. EROSION CONTROL MEASURES WILL BE MAINTAINED AT ALL TIMES. IF FULL IMPLEMENTATION OF THE APPROVED PLAN DOES NOT PROVIDE FOR EFFECTIVE EROSION CONTROL, ADDITIONAL EROSION AND SEDIMENT CONTROL MEASURES SHALL BE IMPLEMENTED TO CONTROL OR TREAT THE SEDIMENT SOURCE AS DIRECTED BY THE ON SITE INSPECTOR OR THE CIVIL ENGINEER.
15. FAILURE TO INSTALL, OPERATE, OR MAINTAIN ALL EROSION CONTROL MEASURES WILL RESULT IN ALL CONSTRUCTION BEING STOPPED ON THE JOB UNTIL SUCH MEASURES ARE CORRECTED BACK TO THE APPROVED EROSION CONTROL PLANS.
16. THE SITE CONTRACTOR WILL BE RESPONSIBLE FOR MAINTENANCE OF ALL EROSION CONTROL MEASURES INCLUDING REPLACING OR REPAIRING ANY DAMAGED DEVICES DUE TO ANY CONSTRUCTION ACTIVITY BY OTHERS.
17. EROSION CONTROL MEASURES SHALL BE INSTALLED PRIOR TO ANY OTHER CONSTRUCTION ACTIVITY AND MAINTAINED UNTIL PERMANENT GROUND COVER IS ESTABLISHED.
18. SEDIMENT AND EROSION CONTROL MEASURES SHOULD BE CHECKED AFTER EACH RAIN EVENT. EACH DEVICE IS TO BE MAINTAINED OR REPLACED IF SEDIMENT ACCUMULATION HAS REACHED ONE HALF THE CAPACITY OF THE DEVICE. ADDITIONAL DEVICES MUST BE INSTALLED IF NEW CHANNELS HAVE DEVELOPED.

INITIAL PHASE EROSION CONTROL NOTES

1. PRIOR TO THE LAND DISTURBING CONSTRUCTION, THE CONTRACTOR SHALL SCHEDULE A PRE-CONSTRUCTION MEETING WITH THE OWNER.
2. THE CONTRACTOR SHALL REVIEW THE PROJECT SEQUENCE SHOWN ON THE PLANS. THE CONTRACTOR SHALL MAINTAIN CAREFUL SCHEDULING AND PERFORMANCE TO ENSURE THAT LAND STRIPPED OF ITS NATURAL COVER IS EXPOSED ONLY IN SMALL QUANTITIES.
3. A COPY OF THE APPROVED LAND DISTURBANCE PLAN SHALL BE PRESENT ON THE SITE AT ALL TIMES.
4. THE ESCAPE OF SEDIMENT FROM THE SITE SHALL BE PREVENTED BY THE INSTALLATION OF EROSION AND SEDIMENT CONTROL MEASURES AND PRACTICES PRIOR TO, OR CONCURRENT WITH, LAND-DISTURBING ACTIVITIES.
5. PRIOR TO COMMENCING LAND DISTURBANCE ACTIVITY, THE LIMITS OF LAND DISTURBANCE SHALL BE CLEARLY AND ACCURATELY DEMARCATED WITH STAKES, RIBBONS, OR OTHER APPROPRIATE MEANS. THE LOCATION AND EXTENT OF ALL AUTHORIZED LAND DISTURBANCE ACTIVITY SHALL BE DEMARCATED FOR THE DURATION OF THE CONSTRUCTION ACTIVITY. NO LAND DISTURBANCE SHALL OCCUR OUTSIDE THE APPROVED LIMITS INDICATED ON THE APPROVED PLANS.
6. PRIOR TO ANY OTHER CONSTRUCTION, A CONSTRUCTION ENTRANCE SHALL BE CONSTRUCTED AT EACH POINT OF ENTRY TO OR EXIT FROM THE SITE OR ONTO ANY PUBLIC ROADWAY.

7. THE FOLLOWING INITIAL EROSION CONTROL MEASURES SHALL BE IMPLEMENTED PRIOR TO ANY OTHER CONSTRUCTION ACTIVITY.
 - A. THE CONSTRUCTION ENTRANCE, CONSISTING OF A MINIMUM PAD SIZE OF 12 FT BY 50 FT WITH A MINIMUM OF 6" THICK STONE. THE STONE SIZE SHOULD CONSIST OF COURSE AGGREGATE BETWEEN 1-1/2" & 3-1/2" IN DIAMETER AND OVERLAIN ON A GEOTEXTILE UNDERLINER. THE GEOTEXTILE UNDERLINER SHALL MEET THE REQUIREMENTS OF AASHTO M288-96, SECTION 7.3 SEPARATION REQUIREMENTS. (ROCK INSTALLATION TO COINCIDE WITH DEMOLITION)
 - B. IMMEDIATELY AFTER THE ESTABLISHMENT OF CONSTRUCTION ENTRANCE, ALL PERIMETER EROSION CONTROL AND STORM WATER MANAGEMENT DEVICES SHALL BE INSTALLED AS SHOWN ON THE INITIAL EROSION CONTROL PLAN.
 - C. GEOTEXTILE SILT FENCE SHOULD BE INSTALLED AT THE PERIMETER OF THE DISTURBED AREA IF CONDITIONS WARRANT INSTALLATION OR SHOWN ON THE PLANS. THE GEOTEXTILE SILT FENCE SHOULD BE PLACED IN ACCORDANCE WITH THE CONNECTICUT EROSION & SEDIMENTATION CONTROL GUIDELINES. THE GEOTEXTILE SILT FENCE SHOULD BE KEPT ERECT AT ALL TIMES AND REPAIRED WHEN REQUESTED BY THE SITE INSPECTOR OR THE PROJECT DESIGN PROFESSIONAL OF RECORD. SILT SHOULD BE REMOVED WHEN ACCUMULATION REACHES 1/2 HEIGHT OF THE BARRIER. THE PERIMETER SILT FENCE SHOULD BE INSPECTED DAILY FOR ANY FAILURES. ANY FAILURES OF SAID FENCING SHOULD BE REPAIRED IMMEDIATELY.
 - D. INLET SEDIMENT PROTECTION MEASURES SHALL BE INSTALLED ON ALL EXISTING STORM STRUCTURES AS SHOWN ON THE PLAN, SEE SEPARATE DETAILS FOR SPECIFICS ON TYPE OF INLET PROTECTION SPECIFIED.
8. AFTER INSTALLATION OF INITIAL EROSION CONTROL MEASURES THE SITE CONTRACTOR SHALL SCHEDULE AN INSPECTION BY THE PROJECT RESIDENT ENGINEER. NO OTHER CONSTRUCTION ACTIVITIES SHALL OCCUR UNTIL THE PROJECT RESIDENT ENGINEER APPROVES THE INSTALLATION OF SAID EROSION CONTROL MEASURES. IF UNFORESEEN CONDITIONS EXIST IN THE FIELD THAT WARRANT ADDITIONAL EROSION CONTROL MEASURES, THE CONTRACTOR MUST CONSTRUCT ANY ADDITIONAL EROSION CONTROL DEVICES DEEMED NECESSARY BY THE SITE INSPECTION.
9. AFTER APPROVAL OF THE INITIAL EROSION CONTROL INSTALLATION, THE CONTRACTOR MAY PROCEED WITH CONSTRUCTION, CLEARING AND GRUBBING ACTIVITIES.
10. NO BURN OR BURY PITS SHALL BE PERMITTED ON THE CONSTRUCTION SITE.

GRADING AND FINAL PHASE EROSION CONTROL NOTES

1. DURING CONSTRUCTION, THE CONTRACTOR SHALL MAINTAIN CAREFUL SCHEDULING AND PERFORMANCE TO ENSURE THAT LAND STRIPPED OF ITS NATURAL GROUND COVER IS EXPOSED ONLY IN SMALL QUANTITIES AND THEREFORE LIMITED DURATIONS, BEFORE PERMANENT EROSION PROTECTION IS ESTABLISHED.
2. SEDIMENT SHALL NOT BE WASHED INTO INLETS. IT SHALL BE REMOVED FROM THE SEDIMENT TRAPS AND DISPOSED OF AND STABILIZED SO THAT IT WILL NOT ENTER THE INLETS AGAIN.
3. EROSION CONTROL DEVICES SHALL BE INSTALLED IMMEDIATELY AFTER GROUND DISTURBANCE OCCURS. THE LOCATION OF SOME OF THE EROSION CONTROL DEVICES MAY HAVE TO BE ALTERED FROM THAT SHOWN ON THE APPROVED PLANS IF DRAINAGE PATTERNS DURING CONSTRUCTION ARE DIFFERENT FROM THE PROPOSED DRAINAGE PATTERNS. IT IS THE CONTRACTOR'S RESPONSIBILITY TO ACCOMPLISH EROSION CONTROL FOR ALL DRAINAGE PATTERNS CREATED AT VARIOUS STAGES DURING CONSTRUCTION. ANY DIFFICULTY IN CONTROLLING EROSION DURING ANY PHASE OF CONSTRUCTION SHALL BE REPORTED TO THE DESIGN PROFESSIONAL IMMEDIATELY.
4. CUT AND FILL SLOPES ARE TO BE AS SHOWN ON PLAN BUT SHALL NOT EXCEED "2H:1V"
5. THE FOLLOWING EROSION CONTROL MEASURES SHALL BE IMPLEMENTED DURING THE PRELIMINARY GRADING PHASE OF CONSTRUCTION.
 - A. GEOTEXTILE SILT FENCE SHALL BE PLACED AS SHOWN ON THE PLANS AND PER THE DETAIL SHOWN ON SHEET 6.
 - B. INLET SEDIMENT PROTECTION MEASURES SHALL BE INSTALLED ON ALL STORM STRUCTURES AS THEY ARE CONSTRUCTED/MODIFIED. SEE PLAN VIEW FOR SPECIFIC TYPE AND SEPARATE DETAILS FOR ADDITIONAL INFORMATION ON TYPE OF INLET PROTECTION SPECIFIED.
 - C. ALL DRAINAGE SWALES SHALL BE APPLIED WITH VEGETATIVE COVER AS SOON AS FINAL GRADE IS ACHIEVED.
 - D. ALL GRADED AREAS SHALL BE APPLIED WITH VEGETATIVE COVER AS SOON AS FINAL GRADE IS ACHIEVED.
6. THE FOLLOWING EROSION CONTROL MEASURES SHALL BE IMPLEMENTED DURING THE FINAL EROSION CONTROL PHASE OF CONSTRUCTION.
 - A. ALL GEOTEXTILE SILT FENCE SHALL BE REMOVED AT PROJECT COMPLETION.
 - B. INLET SEDIMENT PROTECTION MEASURES SHALL BE REMOVED.
 - C. ALL PERMANENT VEGETATIVE COVER WILL BE FULLY ESTABLISHED.
 - D. CONSTRUCTION ENTRANCE WILL BE REMOVED AT PROJECT COMPLETION.
7. UPON COMPLETION OF THE PROJECT AND RECEIPT OF CERTIFICATE OF OCCUPANCY, THE CONTRACTOR SHALL REMOVE ALL TEMPORARY EROSION CONTROL MEASURES AND DISPOSE OF THEM UNLESS NOTED ON PLANS.

DWG INFO: C:\BOS\Projects\10630\Detail Design\State\per10630\CADD\Permit\10630-02.dwg, October 20, 2020, 2:31 PM, CADYANGLESAS, (C) MOFFATT AND NICHOL



PERMITTING SET
ISSUED: 10/23/2020
NOT TO BE USED FOR CONSTRUCTION



NOTES - 1 OF 2
STATE PIER INFRASTRUCTURE IMPROVEMENTS
STATE PIER FACILITY - NEW LONDON, CT



Digitally signed by
Eric D Smith
DN: c=US,
o=Unaffiliated,
ou=A01410C000001
71CC9B22C1000095
D6, cn=Eric D Smith
Date: 2020.10.27
09:18:26 -0400'

DWG INFO: 0190359-Project\190359-Detail Design\State\per500-CADD_Active\PermitSet\106300-00.dwg; April 28, 2020 - 2:25 PM; CMOY\NGLESAS; (C) MOFFATT AND NICHOL

EROSION, SEDIMENTATION, AND POLLUTION CONTROL PLAN (ESPC)

EROSION AND SEDIMENT CONTROLS

1. ALL PERIMETER GEOTEXTILE SILT FENCES AND CONSTRUCTION EXITS SHALL BE IN PLACE PRIOR TO ANY LAND DISTURBING ACTIVITIES.
2. WHEN CONSTRUCTION ACTIVITIES HAVE CEASED IN AN AREA, THAT AREA SHALL BE STABILIZED WITHIN 14 DAYS.

OTHER CONTROLS

1. NO WASTE WILL BE DISPOSED OF INTO STORMWATER INLETS OR WATERS OF THE STATE.

WASTE MATERIALS

1. ALL WASTE MATERIALS WILL BE COLLECTED AND STORED IN A SECURELY LIDDED METAL DUMPSTER. THE DUMPSTER WILL MEET ALL SOLID WASTE MANAGEMENT REGULATIONS. ALL TRASH AND CONSTRUCTION DEBRIS FROM THE SITE WILL BE DEPOSITED IN THE DUMPSTER. THE DUMPSTER WILL BE EMPTIED A MINIMUM OF ONCE PER WEEK OR MORE OFTEN IF NECESSARY AND TRASH WILL BE HAULED AS REQUIRED BY LOCAL REGULATIONS. NO CONSTRUCTION WASTE WILL BE BURIED ON-SITE.
2. ALL PERSONNEL WILL BE INSTRUCTED ON PROPER PROCEDURES FOR WASTE DISPOSAL. A NOTICE STATING THESE PRACTICES WILL BE POSTED AT THE JOBSITE AND THE CONTRACTOR WILL BE RESPONSIBLE FOR SEEING THAT THESE PROCEDURES ARE FOLLOWED.

HAZARDOUS WASTE

1. ALL HAZARDOUS WASTE MATERIALS WILL BE DISPOSED OF IN THE MANNER SPECIFIED BY LOCAL STATE, AND/OR FEDERAL REGULATIONS AND BY THE MANUFACTURER OF SUCH PRODUCTS. THE JOB SITE SUPERINTENDENT, WHO WILL ALSO BE RESPONSIBLE FOR SEEING THAT THESE PRACTICES ARE FOLLOWED, WILL INSTRUCT SITE PERSONNEL IN THESE PRACTICES. MATERIAL SAFETY DATA SHEETS (MSDS'S) FOR EACH SUBSTANCE WITH HAZARDOUS PROPERTIES THAT IS USED ON THE JOB SITE WILL BE OBTAINED AND USED FOR THE PROPER MANAGEMENT OF POTENTIAL WASTES THAT MAY RESULT FROM THESE PRODUCTS. AN MSDS WILL BE POSTED IN THE IMMEDIATE AREA WHERE SUCH PRODUCT IS STORED AND/OR USED AND ANOTHER COPY OF EACH MSDS WILL BE MAINTAINED IN THE ESPCP FILE AT THE JOB SITE CONSTRUCTION TRAILER OFFICE. EACH EMPLOYEE WHO MUST HANDLE A SUBSTANCE WITH HAZARDOUS PROPERTIES WILL BE INSTRUCTED ON THE USE OF MSDS SHEETS AND THE SPECIFIC INFORMATION IN THE APPLICABLE MSDS FOR THE PRODUCT HE/SHE IS USING, PARTICULARLY REGARDING SPILL CONTROL TECHNIQUES.
2. THE CONTRACTOR WILL IMPLEMENT THE SPILL PREVENTION CONTROL AND COUNTERMEASURES (SPCC) PLAN FOUND WITHIN THE ESPCP AND WILL TRAIN ALL PERSONNEL IN THE PROPER CLEANUP AND HANDLING OF SPILLED MATERIALS. NO SPILLED HAZARDOUS MATERIALS OR HAZARDOUS WASTES WILL BE ALLOWED TO COME IN CONTACT WITH STORMWATER DISCHARGES. IF SUCH CONTACT OCCURS, THE STORMWATER DISCHARGE WILL BE CONTAINED ON SITE UNTIL APPROPRIATE MEASURES IN COMPLIANCE WITH STATE AND FEDERAL REGULATIONS ARE TAKEN TO DISPOSE OF SUCH CONTAMINATED STORMWATER. IT SHALL BE THE RESPONSIBILITY OF THE JOB SITE SUPERINTENDENT TO PROPERLY TRAIN ALL PERSONNEL IN THE USE OF THE SPCC PLAN.

SANITARY WASTES

1. A MINIMUM OF ONE PORTABLE SANITARY UNIT WILL BE PROVIDED FOR EVERY TEN (10) WORKERS ON THE SITE. ALL SANITARY WASTE WILL BE COLLECTED FROM THE PORTABLE SANITARY UNITS A MINIMUM OF ONE TIME PER WEEK BY A LICENSED PORTABLE FACILITY PROVIDER IN COMPLETE COMPLIANCE WITH LOCAL AND STATE REGULATIONS.
2. ALL SANITARY WASTE UNITS WILL BE LOCATED IN AN AREA WHERE THE LIKELIHOOD OF THE UNIT CONTRIBUTING TO STORMWATER DISCHARGE IS NEGLIGIBLE. ADDITIONAL CONTAINMENT BMP'S MUST BE IMPLEMENTED, SUCH AS GRAVEL BAGS OR SPECIALLY DESIGNED PLASTIC SKID CONTAINERS AROUND THE BASE, TO PREVENT WASTES FROM CONTRIBUTING TO STORMWATER DISCHARGES. THE LOCATION OF THE SANITARY WASTES UNITS MUST BE IDENTIFIED ON THE EROSION CONTROL PLAN GRADING PHASE BY THE CONTRACTOR ONCE THE LOCATIONS HAVE BEEN DETERMINED.

OFFSITE VEHICLE TRACKING

1. A STABILIZED CONSTRUCTION ENTRANCE IS TO BE PROVIDED TO HELP REDUCE VEHICLE TRACKING OF SEDIMENT. SEE SHEET 4 FOR CONSTRUCTION ENTRANCE DETAILS. THE PAVED STREET ADJACENT TO THE SITE EXIT WILL BE INSPECTED DAILY FOR TRACKING OF MUD, DIRT OR ROCK. DUMP TRUCKS HAULING MATERIAL FROM THE CONSTRUCTION SITE WILL BE COVERED WITH A TARPAULIN.

INVENTORY FOR POLLUTION PREVENTION PLAN

1. THE FOLLOWING MATERIALS ARE EXPECTED ON-SITE DURING CONSTRUCTION: CONCRETE PRODUCTS, ASPHALT, PETROLEUM BASED FUELS AND LUBRICANTS FOR EQUIPMENT, TAR, METAL REINFORCING, PAINTS/FINISHES, PAINT SOLVENTS, LUMBER, CRUSHED STONE, PLASTIC, METAL, AND CONCRETE PIPES.

SPILL PREVENTION

1. PRACTICES SUCH AS GOOD HOUSEKEEPING, PROPER HANDLING OF HAZARDOUS PRODUCTS AND PROPER SPILL CONTROL PRACTICES WILL BE FOLLOWED TO REDUCE THE RISK OF SPILLS AND SPILLS FROM DISCHARGING INTO STORMWATER RUNOFF.

GOOD HOUSEKEEPING

1. QUANTITIES OF PRODUCTS STORED ON-SITE WILL BE LIMITED TO THE AMOUNT NEEDED FOR THE JOB.
2. PRODUCTS AND MATERIALS WILL BE STORED IN A NEAT, ORDERLY MANNER IN APPROPRIATE CONTAINERS PROTECTED FROM RAINFALL, WHERE POSSIBLE.
3. PRODUCTS WILL BE KEPT IN THEIR ORIGINAL CONTAINERS WITH MANUFACTURER LABELS LEGIBLE AND VISIBLE.
4. PRODUCTS MIXING, DISPOSAL AND DISPOSAL OF PRODUCT CONTAINERS WILL BE ACCORDING TO THE MANUFACTURER'S RECOMMENDATIONS.
5. THE CONTRACTOR WILL INSPECT SUCH MATERIALS TO ENSURE PROPER USE, STORAGE AND DISPOSAL.

PRODUCT SPECIFIC PRACTICES

1. PETROLEUM BASED PRODUCTS - CONTAINERS FOR PRODUCTS SUCH AS FUELS, LUBRICANTS AND TARS WILL BE INSPECTED DAILY FOR LEAKS AND SPILLS. THIS INCLUDES ON-SITE VEHICLE AND MACHINERY DAILY INSPECTION AND REGULAR PREVENTIVE MAINTENANCE OF SUCH EQUIPMENT. EQUIPMENT MAINTENANCE AREAS WILL BE LOCATED AWAY FROM STATE WATER, NATURAL DRAINS AND STORMWATER DRAINAGE INLETS. IN ADDITION, TEMPORARY FUELING TANKS SHALL HAVE A SECONDARY CONTAINMENT LINER TO PREVENT/MINIMIZE SITE CONTAMINATION. DISCHARGE OF OILS, FUELS AND LUBRICANTS IS PROHIBITED. PROPER DISPOSAL METHODS WILL INCLUDE COLLECTION IN A SUITABLE CONTAINER AND DISPOSAL AS REQUIRED BY LOCAL AND STATE REGULATIONS.
2. PAINTS/FINISHES/SOLVENTS - ALL PRODUCTS WILL BE STORED IN TIGHTLY SEALED ORIGINAL CONTAINERS WHEN NOT IN USE. EXCESS PRODUCT WILL NOT BE DISCHARGED TO THE STORMWATER COLLECTION SYSTEM. EXCESS PRODUCT, MATERIALS USED WITH THESE PRODUCTS AND PRODUCT CONTAINERS WILL BE DISPOSED OF ACCORDING TO MANUFACTURER'S SPECIFICATIONS AND RECOMMENDATIONS.
3. CONCRETE TRUCK WASHING - NO CONCRETE TRUCKS WILL BE ALLOWED TO WASH OUT OR DISCHARGE SURPLUS CONCRETE OR DRUM WASH WATER ON THE OWNER'S PROPERTY.
4. FERTILIZER/HERBICIDES - THESE PRODUCTS WILL BE APPLIED AT RATES THAT DO NOT EXCEED THAT MANUFACTURER'S SPECIFICATIONS OR ABOVE THE GUIDELINES SET FORTH IN THE CROP .
5. BUILDING MATERIALS/FORMWORK - NO BUILDING OR CONSTRUCTION MATERIALS WILL BE BURIED OR DISPOSED OF ON-SITE. ALL SUCH MATERIAL WILL BE DISPOSED OF IN PROPER WASTE DISPOSAL PROCEDURES.

SPILL CLEANUP AND CONTROL PRACTICES

1. LOCAL, STATE AND MANUFACTURER'S RECOMMENDED METHODS FOR SPILL CLEANUP WILL BE CLEARLY POSTED AND PROCEDURES WILL BE MADE AVAILABLE TO SITE PERSONNEL.
2. MATERIAL AND EQUIPMENT NECESSARY FOR SPILL CLEANUP WILL BE KEPT IN THE MATERIAL STORAGE AREAS. TYPICAL MATERIALS AND EQUIPMENT INCLUDES, BUT IS NOT LIMITED TO, BROOMS, DUSTPANS, MOPS, RAGS, GLOVES, GOGGLES, CAT LITTER, SAND, SAWDUST AND PROPERLY LABELED PLASTIC AND METAL WASTE CONTAINERS.
3. SPILL PREVENTION PRACTICES AND PROCEDURES WILL BE REVIEWED AFTER A SPILL AND ADJUSTED AS NECESSARY TO PREVENT FUTURE SPILLS.
4. ALL SPILLS WILL BE CLEANED UP IMMEDIATELY UPON DISCOVERY. ALL SPILLS WILL BE REPORTS AS REQUIRED BY LOCAL, STAT, AND FEDERAL REGULATIONS.
5. FOR SPILLS THAT IMPACT SURFACE WATER (LEAVE A SHEEN ON SURFACE WATER), THE NATIONAL RESPONSE CENTER (NRC) WILL BE CONTACTED WITHIN 24 HOURS AT 1-800-426-2675.
6. FOR SPILLS OF UNKNOWN AMOUNT, THE NATIONAL RESPONSE CENTER (NRC) WILL BE CONTACTED WITHIN 24 HOURS AT 1-800-426-2675.
7. FOR SPILLS GREATER THAN 25 GALLONS AND NO SURFACE WATER IMPACTS, THE SPILL WILL BE CLEANED UP AND LOCAL AGENCIES WILL BE CONTACTED AS REQUIRED.

HANDLING OF SOIL MATERIALS

1. EXCAVATED SOIL MATERIALS, EXCEPT FOR EXCAVATED ASPHALT AND CONCRETE, SHALL BE USED FOR BACKFILLING AND FILLING PROVIDED IT MEETS THE FOLLOWING REQUIREMENTS:
 - A. THE MATERIAL DOES NOT CONTAIN DELETERIOUS AMOUNTS OF:
 - a. ORGANIC CLAYS, SILTS, OR PEATS
 - b. MISCELLANEOUS DEBRIS, SUCH AS BUT NOT LIMITED TO, TIMBER, METAL, PLASTICS, GLASS, OR REFUSE
 - c. STONES OR CONCRETE PIECES LARGER THAN THREE (3) INCHES IN SIZE.
 - B. THE MATERIAL IS NOT FROZEN AND DOES NOT CONTAIN ICE.
 - C. THE MATERIAL IS NOT OIL STAINED AND DOES NOT HAVE A NOTICEABLE "OIL ODOR".
 - D. THE MATERIAL IS COMPACTABLE AS DETERMINED BY THE OWNER'S REPRESENTATIVE.
2. ALL EXCAVATED SOIL THAT EXHIBITS EVIDENCE OF CONTAMINATION INCLUDING, BUT NOT LIMITED TO, SHEENS, STAINING, AND ODORS SHALL BE SEGREGATED FROM SOIL NOT EXHIBITING SUCH EVIDENCE. SOIL WITH INDICATORS OF CONTAMINATION SHALL NOT BE USED AS BACKFILL.

3. TRANSPORT ALL EXCAVATED SOIL EXHIBITING EVIDENCE OF CONTAMINATION TO THE STOCKPILE AREA AS DIRECTED BY THE OWNER'S REPRESENTATIVE.
4. SUBMIT TO THE OWNER'S REPRESENTATIVE A SOIL STOCKPILE MANAGEMENT PLAN DESCRIBING MEASURES FOR SOIL CONTAINMENT WITHIN THE STOCKPILE AREA AND MAINTENANCE OF THE STOCKPILE AREA.
5. THE OWNER'S REPRESENTATIVE WILL PERFORM REQUIRED SOIL SAMPLING AND TESTING FOR OFF-SITE SOIL REUSE OR DISPOSAL. THE OWNER'S REPRESENTATIVE WILL PROVIDE TO THE CONTRACTOR A COPY OF THE LABORATORY REPORT CONTAINING THE LABORATORY ANALYTICAL DATA.
6. WHEN DIRECTED BY THE OWNER'S REPRESENTATIVE, TRANSPORT AND REUSE OR DISPOSE THE SOIL MATERIALS OFF AUTHORITY PROPERTY IN ACCORDANCE WITH ALL APPLICABLE FEDERAL, STATE AND LOCAL REGULATIONS.
7. SUBMIT INFORMATION ON THE TRANSPORTERS OF SOIL MATERIALS INCLUDING CURRENT APPLICABLE STATE-ISSUED WASTE TRANSPORTERS PERMITS TO THE OWNER'S REPRESENTATIVE FOR APPROVAL AT LEAST 2 WEEKS PRIOR TO THE COMMENCEMENT OF TRUCKING ACTIVITIES.
8. SUBMIT DOCUMENTATION OF REUSE OR DISPOSAL OF SOIL MATERIALS DETAILING EXECUTION OF MANIFESTS OR BILLS OF LADING FOR ALL SOIL MATERIAL REMOVED AND TRANSPORTED FROM THE SITE. DOCUMENTS SHALL BE SIGNED BY THE OWNER'S REPRESENTATIVE PRIOR TO THE REMOVAL OF SOIL OFF-SITE. EXECUTED MANIFESTS OR BILLS OF LADING SHALL BE SIGNED BY THE RECEIVING FACILITY AND COPIES SHALL BE PROVIDED TO THE OWNER'S REPRESENTATIVE WITHIN 72 HOURS.

INSPECTIONS

1. EACH DAY WHEN ANY TYPE OF CONSTRUCTION ACTIVITY HAS TAKEN PLACE AT THE CONTRACTOR'S SITE, QUALIFIED PERSONNEL PROVIDED BY THE CONTRACTOR SHALL INSPECT: (A) ALL AREAS AT THE CONTRACTOR'S SITE WHERE PETROLEUM PRODUCTS ARE STORED, USED, OR HANDLED FOR SPILLS AND LEAKS FROM VEHICLES AND EQUIPMENT; (B) ALL LOCATIONS AT THE CONTRACTOR'S SITE WHERE VEHICLES ENTER OF EXIT THE SITE FOR EVIDENCE OF OFF-SITE SEDIMENT TRACKING; AND (C) MEASURE RAINFALL ONCE EACH TWENTY-FOUR HOUR PERIOD AT THE SITE. THESE INSPECTIONS MUST BE CONDUCTED UNTIL PROJECT COMPLETION.
2. QUALIFIED PERSONNEL (PROVIDED BY THE CONTRACTOR) SHALL INSPECT AT LEAST ONCE EVERY SEVEN (7) CALENDAR DAYS AND WITHIN 24 HOURS OF THE END OF A STORM THAT IS 0.5 INCHES OR GREATER THE FOLLOWING: (A) DISTURBED AREAS OF THE CONTRACTOR'S CONSTRUCTION SITE THAT HAVE NOT UNDERGONE FINAL STABILIZATION; (B) AREAS USED BY THE CONTRACTOR FOR STORAGE OF MATERIALS THAT ARE EXPOSED TO PRECIPITATION THAT HAVE NOT UNDERGONE FINAL STABILIZATION; AND (C) STRUCTURAL CONTROL MEASURES. EROSION AND SEDIMENT CONTROL MEASURES IDENTIFIED IN THE PLAN APPLICABLE TO THE CONTRACTOR'S SITE SHALL BE OBSERVED TO ENSURE THAT THEY ARE OPERATING CORRECTLY. WHERE DISCHARGE LOCATIONS OR POINTS ARE ACCESSIBLE, THEY SHALL BE INSPECTED TO ASCERTAIN WHETHER EROSION CONTROL MEASURES ARE EFFECTIVE IN PREVENTING SIGNIFICANT IMPACTS TO RECEIVING WATER(S).
3. QUALIFIED PERSONNEL (PROVIDED BY THE CONTRACTOR) SHALL INSPECT AT LEAST ONCE PER MONTH UNTIL PROJECT COMPLETION THE AREAS OF THE SITE THAT HAVE UNDERGONE FINAL STABILIZATION. THESE AREAS SHALL BE INSPECTED FOR EVIDENCE OF, OR THE POTENTIAL FOR, POLLUTANTS ENTERING THE DRAINAGE SYSTEM AND THE RECEIVING WATER(S). EROSION AND SEDIMENT CONTROL MEASURES IDENTIFIED IN THE PLAN SHALL BE OBSERVED TO ENSURE THAT THEY ARE OPERATING CORRECTLY. WHERE DISCHARGE LOCATIONS OR POINTS ARE ACCESSIBLE, THEY SHALL BE INSPECTED TO ASCERTAIN WHETHER EROSION CONTROL MEASURES ARE EFFECTIVE IN PREVENTING SIGNIFICANT IMPACTS TO RECEIVING WATER(S).
4. BASED ON THE RESULTS OF EACH INSPECTION, THE SITE DESCRIPTION AND THE POLLUTION PREVENTION AND CONTROL MEASURES IDENTIFIED IN THE EROSION, SEDIMENTATION AND POLLUTION CONTROL PLAN, THE PLAN SHALL BE REVISED AS APPROPRIATE NOT LATER THAN SEVEN (7) CALENDAR DAYS FOLLOWING EACH INSPECTION. IMPLEMENTATION OF SUCH CHANGES SHALL BE MADE AS PRACTICAL BUT IN NO CASE LATER THAN SEVEN (7) CALENDAR DAYS FOLLOWING EACH INSPECTION.
5. A REPORT SUMMARIZING THE SCOPE OF EACH INSPECTION AND THE NAME(S) OF PERSONNEL MAKING EACH INSPECTION, THE DATE(S) OF EACH INSPECTION, MAJOR OBSERVATIONS RELATING TO THE IMPLEMENTATION OF THE EROSION, SEDIMENTATION AND POLLUTION CONTROL PLAN AND ACTIONS TAKEN SHALL BE MADE AND RETAINED AT THE SITE OR BE READILY AVAILABLE AT A DESIGNATED ALTERNATE LOCATION UNTIL THE ENTIRE SITE OR THAT PORTION OF A CONSTRUCTION PROJECT THAT HAS BEEN PHASED HAS UNDERGONE FINAL STABILIZATION. SUCH REPORTS SHALL IDENTIFY ANY INCIDENTS OF NON-COMPLIANCE. WHERE THE REPORT DOES NOT IDENTIFY ANY INCIDENTS OF NON-COMPLIANCE, THE REPORT SHALL CONTAIN A CERTIFICATION THAT THE FACILITY IS IN COMPLIANCE WITH THE EROSION, SEDIMENTATION AND POLLUTION CONTROL PLAN.

PROJECT VERTICAL DATUM	
NEW LONDON, THAMES RIVER, CT STATION ID 8461490	ELEVATIONS (NAVD88)
100 YEAR BASE FLOOD	+11.0
HIGHEST OBSERVED	+8.73
NGVD29	+2.85
COASTAL JURISDICTION LINE	+2.1
MHHW	+1.21
MHW	+0.92
NAVD88	0.00
MSL	-0.30
MTL	-0.37
MLW	-1.65
MLLW	-1.84
LOWEST OBSERVED	-5.84

NOTE: MLLW ELEVATIONS ARE 1.84' ABOVE NAVD88.

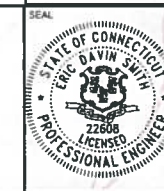

Digitally signed by Eric D Smith
DN: c=US,
o=Unaffiliated,
ou=A01410C000001
71CC9B22C1000095
D6, cn=Eric D Smith
Date: 2020.10.27
09:22:30 -04'00'



PERMITTING SET
ISSUED: 10/23/2020
NOT TO BE USED FOR CONSTRUCTION



NOTES - 2 OF 2
STATE PIER INFRASTRUCTURE IMPROVEMENTS
STATE PIER FACILITY - NEW LONDON, CT

SEDIMENT FENCE Sd1

DEFINITION

A TEMPORARY SEDIMENT BARRIER CONSISTING OF A FILTER FABRIC STRETCHED ACROSS AND ATTACHED TO SUPPORTING POSTS AND ENTRENCHED. THE SEDIMENT FENCE IS CONSTRUCTED OF STAKES AND SYNTHETIC FILTER FABRIC WITH A RIGID WIRE FENCE BACKING WHERE NECESSARY FOR SUPPORT. SEDIMENT FENCE CAN BE PURCHASED WITH POCKETS PRESEWN TO ACCEPT USE OF STEEL FENCE POSTS.

PURPOSE

A SEDIMENT FENCE INTERCEPTS AND DETAINS SMALL AMOUNTS OF SEDIMENT FROM DISTURBED AREAS DURING CONSTRUCTION OPERATIONS AND REDUCES RUNOFF VELOCITY DOWN A SLOPE. SEDIMENT FENCES MAY ALSO BE USED TO CATCH WIND-BLOWN SAND AND TO CREATE AN ANCHOR FOR SAND DUNE CREATION.

DESIGN RECOMMENDATIONS

DEPTH OF IMPOUNDED WATER SHOULD NOT EXCEED 1.5 FEET AT ANY POINT ALONG THE FENCE. DRAINAGE AREA LIMITED TO 1/4 ACRE PER 100 FT OF FENCE, AND NO MORE THAN 1.5 ACRES IN TOTAL, OR IN COMBINATION WITH A SEDIMENT BASIN ON A LARGER SITE. AREA IS FURTHER RESTRICTED BY SLOPE STEEPNESS AS SHOWN IN THE FOLLOWING TABLE.

MAXIMUM SLOPE	
LAND SLOPE (%)	DISTANCE ABOVE FENCE (FEET)
2	250
5	180
10	100
20	50
30	30

MATERIALS AND USE

FILTER FABRIC

THE FILTER FABRIC USED IN A SEDIMENT FENCE MUST HAVE SUFFICIENT STRENGTH TO WITHSTAND VARIOUS STRESS CONDITIONS. IT ALSO MUST HAVE THE ABILITY TO ALLOW PASSAGE OF WATER WHILE RETAINING SOIL PARTICLES. FILTER FABRIC FOR A SEDIMENT FENCE IS AVAILABLE COMMERCIALY.

SUPPORT POSTS

FOUR-INCH DIAMETER PINE, 1.33 LB./LINEAR FT. STEEL, OR SOUND QUALITY HARDWOOD WITH A MINIMUM CROSS SECTIONAL AREA OF 3.0 SQUARE INCHES. STEEL POSTS SHOULD HAVE PROJECTIONS FOR FASTENING FABRIC. DRIVE POSTS SECURELY, AT LEAST 16 INCHES INTO THE GROUND, ON THE DOWNSLOPE SIDE OF THE TRENCH. SPACE POSTS A MAXIMUM OF 8 FEET IF FENCE IS SUPPORTED BY WIRE, 6 FEET IF EXTRA-STRENGTH FABRIC IS USED WITHOUT SUPPORT WIRE. ADJUST SPACING TO PLACE POSTS AT LOW POINTS ALONG THE FENCE LINE.

SUPPORT WIRE

WIRE FENCE (14 GAUGE WITH 6-INCH MESH) IS REQUIRED TO SUPPORT STANDARD STRENGTH FABRIC.

REINFORCED, STABILIZED OUTLETS

ANY OUTLET WHERE STORM FLOW BYPASS OCCURS MUST BE STABILIZED AGAINST EROSION. SET OUTLET ELEVATION SO THAT WATER DEPTH CANNOT EXCEED 1.5 FEET AT THE LOWEST POINT ALONG THE FENCE LINE.

SET FABRIC HEIGHT AT 1 FOOT MAXIMUM BETWEEN SUPPORT POSTS SPACED NO MORE THAN 4 FEET APART. INSTALL A HORIZONTAL BRACE BETWEEN THE SUPPORT POSTS TO SERVE AS AN OVERFLOW WEIR AND TO SUPPORT TOP OF FABRIC. PROVIDE A RIPRAP SPLASH PAD A MINIMUM 5 FEET WIDE, 1 FOOT DEEP, AND 5 FEET LONG ON LEVEL GRADE. THE FINISHED SURFACE OF THE RIPRAP SHOULD BLEND WITH SURROUNDING AREA, ALLOWING NO OVERFALL. THE AREA AROUND THE PAD MUST BE STABLE.

CONSTRUCTION RECOMMENDATIONS

DIG A TRENCH APPROXIMATELY 8 INCHES DEEP AND 4 INCHES WIDE, OR A V-TRENCH; ALONG THE LINE OF THE FENCE, UPSLOPE SIDE. FASTEN SUPPORT WIRE FENCE SECURELY TO THE UPSLOPE SIDE OF FENCE POSTS WITH WIRE TIES OR STAPLES. WIRE SHOULD EXTEND 6 INCHES INTO THE TRENCH. ATTACH CONTINUOUS LENGTH OF FABRIC TO UPSLOPE SIDE OF FENCE POSTS. AVOID JOINTS, PARTICULARLY AT LOW POINTS IN THE FENCE LINE. WHERE JOINTS ARE NECESSARY, FASTEN FABRIC SECURELY TO SUPPORT POSTS AND OVERLAP TO THE NEXT POST. PLACE THE BOTTOM ONE FOOT OF FABRIC IN THE TRENCH. BACKFILL WITH COMPACTED EARTH OR GRAVEL. FILTER CLOTH SHALL BE FASTENED SECURELY TO THE WOVEN WIRE FENCE WITH TIES SPACED EVERY 24 INCHES AT THE TOP, MID-SECTION, AND BOTTOM. TO REDUCE MAINTENANCE, A SHALLOW SEDIMENT STORAGE AREA MAY BE EXCAVATED ON THE UPSLOPE SIDE OF FENCE WHERE SEDIMENTATION IS EXPECTED. PROVIDE GOOD ACCESS TO DEPOSITION AREAS FOR CLEANOUT AND MAINTENANCE. SEDIMENT FENCES SHOULD BE REMOVED WHEN THEY HAVE SERVED THEIR USEFUL PURPOSE, BUT NOT BEFORE THE UPSLOPE AREA HAS BEEN PERMANENTLY STABILIZED. RETAINED SEDIMENT MUST BE REMOVED AND PROPERLY DISPOSED OF, OR MULCHED AND SEEDDED.

MAINTENANCE

A SEDIMENT FENCE REQUIRES A GREAT DEAL OF MAINTENANCE. SILT FENCES SHOULD BE INSPECTED IMMEDIATELY AFTER EACH RAINFALL AND AT LEAST DAILY DURING PROLONGED RAINFALL. REPAIR AS NECESSARY. REMOVE SEDIMENT DEPOSITS PROMPTLY TO PROVIDE ADEQUATE STORAGE VOLUME FOR THE NEXT RAIN AND TO REDUCE PRESSURE ON FENCE. TAKE CARE TO AVOID UNDERMINING FENCE DURING CLEANOUT. IF THE FABRIC TEARS, DECOMPOSES, OR IN ANY WAY BECOMES INEFFECTIVE, REPLACE IT IMMEDIATELY. REPLACE BURLAP USED IN SEDIMENT FENCES AFTER NO MORE THAN 60 DAYS. REMOVE ALL FENCING MATERIALS AFTER THE CONTRIBUTING DRAINAGE AREA HAS BEEN PROPERLY STABILIZED. SEDIMENT DEPOSITS REMAINING AFTER THE FABRIC HAS BEEN REMOVED SHOULD BE GRADED TO CONFORM WITH THE EXISTING TOPOGRAPHY AND VEGETATED.

SEDIMENT FENCE

SCALE: N.T.S.

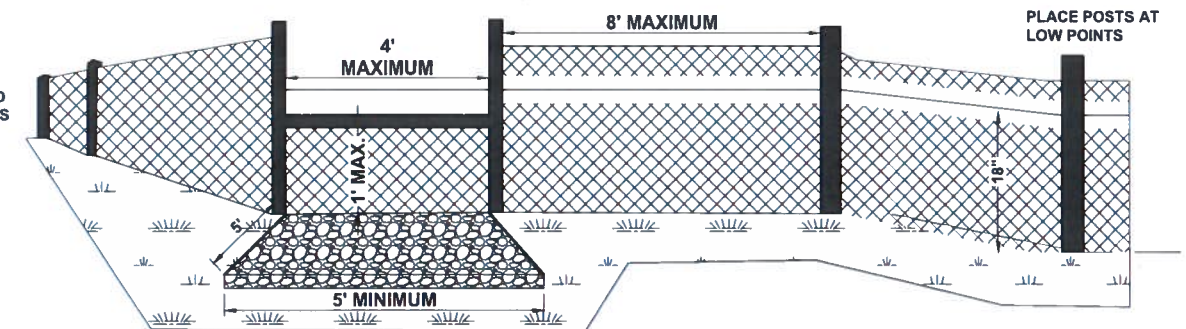
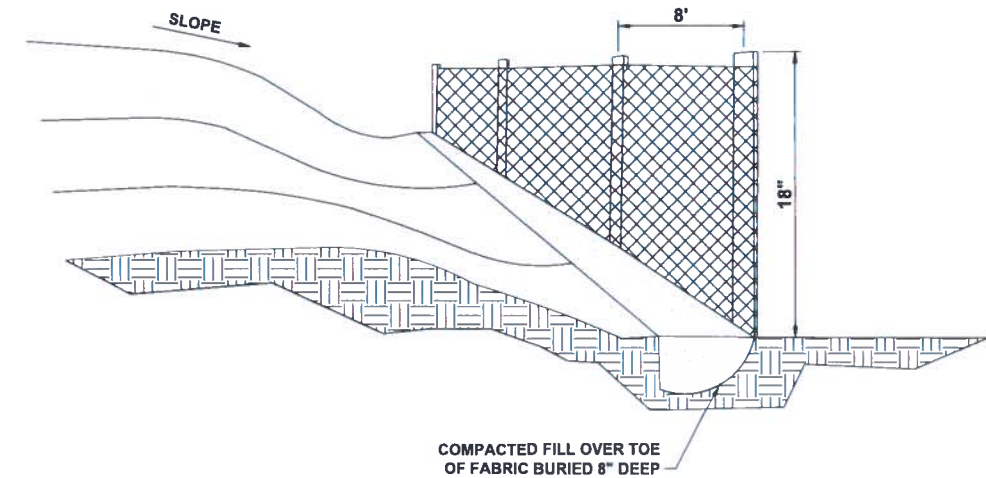

CONSTRUCTION ENTRANCE Co

DEFINITION

A TEMPORARY STONE-STABILIZED PAD LOCATED AT POINTS OF VEHICULAR INGRESS AND EGRESS ON A CONSTRUCTION SITE.

PURPOSE

TO PROVIDE A STABLE ENTRANCE AND EXIT FROM A CONSTRUCTION SITE AND KEEP MUD AND SEDIMENT OFF PUBLIC ROADS.

DESIGN RECOMMENDATIONS

REMOVE ALL VEGETATION AND OTHER OBJECTIONABLE MATERIAL FROM THE FOUNDATION AREA. GRADE AND CROWN FOUNDATION FOR POSITIVE DRAINAGE. STONE FOR A STABILIZED CONSTRUCTION ENTRANCE SHALL BE 1 TO 3-INCH STONE, RECLAIMED STONE, OR RECYCLED CONCRETE EQUIVALENT PLACED ON A STABLE FOUNDATION AS SPECIFIED IN THE PLAN. PAD DIMENSIONS: THE MINIMUM LENGTH OF THE GRAVEL PAD SHOULD BE 50 FEET, EXCEPT

FOR A SINGLE RESIDENTIAL LOT WHERE A 30 FOOT MINIMUM LENGTH MAY BE USED. LONGER ENTRANCES WILL PROVIDE BETTER CLEANING ACTION. THE PAD SHOULD EXTEND THE FULL WIDTH OF THE CONSTRUCTION ACCESS ROAD OR 10 FEET WHICHEVER IS GREATER. THE AGGREGATE SHOULD BE PLACED AT LEAST SIX INCHES THICK. A GEOTEXTILE FILTER FABRIC SHALL BE PLACED BETWEEN THE STONE FILL AND THE EARTH SURFACE BELOW THE PAD TO REDUCE THE MIGRATION OF SOIL PARTICLES FROM THE UNDERLYING SOIL INTO THE STONE AND VICE VERSA. FILTER CLOTH IS NOT REQUIRED FOR A SINGLE FAMILY RESIDENCE LOT. IF THE SLOPE TOWARD THE ROAD EXCEEDS 2%, CONSTRUCT A RIDGE, 6 TO 8 INCHES HIGH WITH 3:1 SIDE SLOPES, ACROSS THE FOUNDATION APPROXIMATELY 15 FT FROM THE ENTRANCE TO DIVERT RUNOFF AWAY FROM THE PUBLIC ROAD. ALL SURFACE WATER THAT IS FLOWING TO OR DIVERTED TOWARD THE CONSTRUCTION ENTRANCE SHOULD BE PIPED BENEATH THE ENTRANCE. IF PIPING IS IMPRACTICAL, A BERM WITH 5:1 SLOPES THAT CAN BE

CROSSED BY VEHICLES MAY BE SUBSTITUTED FOR THE PIPE. WASHING: IF THE SITE CONDITIONS ARE SUCH THAT THE MAJORITY OF MUD IS NOT REMOVED FROM THE VEHICLE TIRES BY THE GRAVEL PAD, THEN THE TIRES SHOULD BE WASHED BEFORE THE VEHICLE ENTERS THE ROAD OR STREET. THE WASH AREA SHOULD BE A LEVEL AREA WITH 3-INCH WASHED STONE MINIMUM, OR A COMMERCIAL RACK. WASH WATER SHOULD BE DIRECTED INTO A SEDIMENT TRAP, A VEGETATED FILTER STRIP, OR OTHER APPROVED SEDIMENT TRAPPING DEVICE. SEDIMENT SHOULD BE PREVENTED FROM ENTERING ANY WATERCOURSES. A FILTER FABRIC FENCE SHOULD BE INSTALLED DOWN-GRADIENT FROM THE CONSTRUCTION ENTRANCE IN ORDER TO CONTAIN ANY SEDIMENT-LADEN RUNOFF FROM THE ENTRANCE.

MAINTENANCE

THE ENTRANCE SHOULD BE MAINTAINED IN A CONDITION THAT WILL PREVENT TRACKING OR FLOWING OF SEDIMENT ONTO PUBLIC RIGHTS-OF-WAY. THIS MAY REQUIRE PERIODIC TOPDRESSING WITH

ADDITIONAL STONE. INSPECT ENTRANCE/EXIT PAD AND SEDIMENT DISPOSAL AREA WEEKLY AND AFTER HEAVY RAINS OR HEAVY USE. REMOVE MUD AND SEDIMENT TRACKED OR WASHED ONTO PUBLIC ROAD IMMEDIATELY. MUD AND SOIL PARTICLES WILL EVENTUALLY CLOG THE VOIDS IN THE GRAVEL AND THE EFFECTIVENESS OF THE GRAVEL PAD WILL NOT BE SATISFACTORY. WHEN THIS OCCURS, THE PAD SHOULD BE TOP-DRESSED WITH NEW STONE. COMPLETE REPLACEMENT OF THE PAD MAY BE NECESSARY WHEN THE PAD BECOMES COMPLETELY CLOGGED. IF WASHING FACILITIES ARE USED, THE SEDIMENT TRAPS SHOULD BE CLEANED OUT AS OFTEN AS NECESSARY TO ASSURE THAT ADEQUATE TRAPPING EFFICIENCY AND STORAGE VOLUME IS AVAILABLE. VEGETATIVE FILTER STRIPS SHOULD BE MAINTAINED TO INSURE A VIGOROUS STAND OF VEGETATION AT ALL TIMES. RESHAPE PAD AS NEEDED FOR DRAINAGE AND RUNOFF CONTROL. REPAIR ANY BROKEN ROAD PAVEMENT IMMEDIATELY. ALL TEMPORARY EROSION AND

SEDIMENT CONTROL MEASURES SHALL BE REMOVED WITHIN 30 DAYS AFTER FINAL SITE STABILIZATION IS ACHIEVED OR AFTER THE TEMPORARY PRACTICES ARE NO LONGER NEEDED. TRAPPED SEDIMENT SHALL BE REMOVED OR STABILIZED ON SITE. DISTURBED SOIL AREAS RESULTING FROM REMOVAL SHALL BE PERMANENTLY STABILIZED.

CONSTRUCTION ENTRANCE

SCALE: N.T.S.

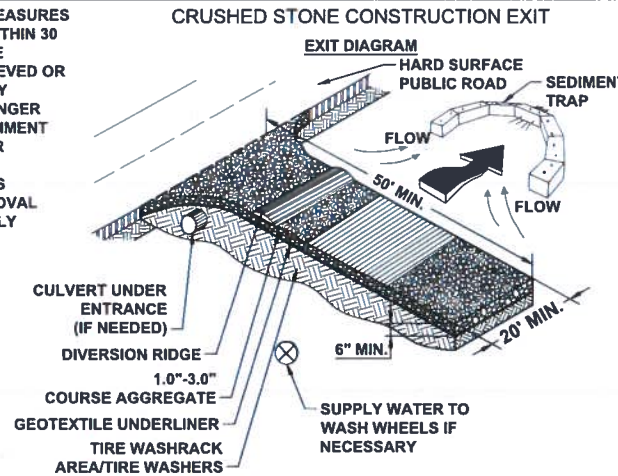

DUST CONTROL ON DISTURBED AREAS Du

DEFINITION

CONTROLLING SURFACE AND AIR MOVEMENT OF DUST ON CONSTRUCTION SITES, ROADS, AND DEMOLITION SITES.

PURPOSE

TO PREVENT SURFACE AND AIR MOVEMENT OF DUST FROM EXPOSED SOIL SURFACES. TO REDUCE THE PRESENCE OF AIRBORNE SUBSTANCES THAT MAY BE HARMFUL OR INJURIOUS TO HUMAN HEALTH, WELFARE, OR SAFETY, OR TO ANIMALS OR PLANT LIFE.

CONDITIONS

THIS PRACTICE IS APPLICABLE TO AREAS SUBJECT TO SURFACE AND AIR MOVEMENT OF DUST WHERE ON AND OFF-SITE DAMAGE MAY OCCUR WITHOUT TREATMENT.

METHOD AND MATERIALS

VEGETATIVE COVER. SEE SPECIFICATION DS2 - DISTURBED AREA STABILIZATION (WITH TEMPORARY SEEDING). TILLAGE THIS PRACTICE IS DESIGNED TO ROUGHEN AND BRING CLODS TO THE SURFACE. IT IS AN EMERGENCY MEASURE THAT SHOULD BE USED BEFORE WIND EROSION STARTS. BEGIN PLOWING ON WINDWARD SIDE OF CHISEL-TYPE PLOWS SPACED ABOUT 12 INCHES APART, SPRING-TOOTHED HARROWS, AND SIMILAR PLOWS ARE EXAMPLES OF EQUIPMENT THAT MAY PRODUCE THE DESIRED EFFECT. IRRIGATION THIS IS GENERALLY DONE AS AN EMERGENCY TREATMENT. SITE IS SPRINKLED WITH WATER UNTIL THE SURFACE IS WET. REPEAT AS NEEDED.

BARRIERS SOLID BOARD FENCES, SNOWFENCES, BURLAP FENCES, CRATE WALLS, BALES OF HAY AND SIMILAR MATERIAL CAN BE USED TO CONTROL AIR CURRENTS AND SOIL BLOWING. BARRIERS PLACED AT RIGHT ANGLES TO PREVAILING CURRENTS AT INTERVALS OF ABOUT 15 TIMES THEIR HEIGHT ARE EFFECTIVE IN CONTROLLING WIND EROSION. CALCIUM CHLORIDE APPLY AT RATE THAT WILL KEEP SURFACE MOIST. MAY NEED RETREATMENT. PERMANENT VEGETATION SEE SPECIFICATION DS3-DISTURBED AREA STABILIZATION (WITH PERMANENT VEGETATION). EXISTING TREES AND LARGE SHRUBS MAY AFFORD VALUABLE PROTECTION IF LEFT IN PLACE.

DUST CONTROL ON DISTURBED AREAS

SCALE: N.T.S.

EROSION AND SEDIMENT CONTROL NOTES - 1 OF 3
STATE PIER INFRASTRUCTURE IMPROVEMENTS
STATE PIER FACILITY - NEW LONDON, CT



PERMITTING SET
ISSUED: 10/23/2020
NOT TO BE USED FOR CONSTRUCTION

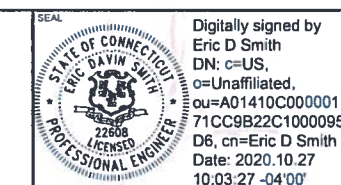

Digitally signed by Eric D Smith
DN: c=US, o=Unaffiliated, ou=A01410C00000171CC9B22C1000095D6, cn=Eric D Smith
Date: 2020.10.27 10:03:27 -04'00'

DWG INFO: C:\BOS\Projects\116330\Detail Design\State pier\500 CADD\ Activel_PermitSet\116330-05.dwg; April 23, 2020 - 6:53 PM; DFRANZESE, C | MOFFATT AND NICHOL

INLET PROTECTION **Sd2**

DEFINITION
A SEDIMENT FILTER OR AN EXCAVATED IMPOUNDING AREA AROUND A STORM DRAIN, DROP INLET, OR CURB INLET.

PURPOSE
USED TO PREVENT SEDIMENT FROM ENTERING STORM DRAINAGE SYSTEMS DURING CONSTRUCTION.

INSTALLATION
FILTER FABRIC SHOULD BE ENOUGH TO REACH FROM SIDE TO SIDE OF THE INLET. ALLOW FABRIC TO BE SAG NO MORE THAN 6" FROM THE TOP OF THE GRATE. FILTER FABRIC SHOULD HAVE AT LEAST A 6" OVERHANG ALONG THE OUTSIDE OF THE GRATE.

MAINTENANCE
REMOVE AND REPLACE FILTER FABRIC WHEN SEDIMENT HAS COVERED A MAJORITY OF FILTER FABRIC IN THE INLET. CAUTION SHOULD BE USED IN ORDER TO MAKE SURE FABRIC DOES NOT DROP IN THE INLET BELOW WHEN REPLACING.

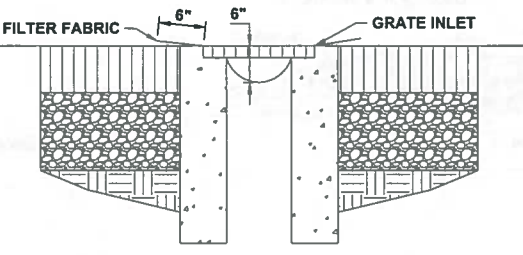

INLET PROTECTION
SCALE: N.T.S.

RIPRAP **St**

DEFINITION
A PERMANENT, EROSION-RESISTANT GROUND COVER OF LARGE, LOOSE, ANGULAR STONE.

PURPOSE
TO PROTECT SLOPES, STREAMBANKS, CHANNELS, OR AREAS SUBJECT TO EROSION BY WAVE ACTION.
ROCK RIPRAP PROTECTS SOIL FROM EROSION DUE TO CONCENTRATED RUNOFF. IT IS USED TO STABILIZE SLOPES THAT ARE UNSTABLE DUE TO SEEPAGE. IT IS ALSO USED TO SLOW THE VELOCITY OF CONCENTRATED RUNOFF WHICH IN TURN INCREASES THE POTENTIAL FOR INFILTRATION.

CONSTRUCTION RECOMMENDATIONS
SUBGRADE FOR THE FILTER MATERIAL, GEOTEXTILE FABRIC OR RIPRAP SHOULD BE CLEARED AND GRUBBED TO REMOVE ALL ROOTS, VEGETATION, AND DEBRIS AND PREPARED TO THE LINES AND GRADES SHOWN ON THE PLANS. EXCAVATE DEEP ENOUGH FOR BOTH FILTER AND RIPRAP. COMPACT ANY FILL MATERIAL TO THE DENSITY OF SURROUNDING UNDISTURBED SOIL.
EXCAVATE A KEYWAY IN STABLE MATERIAL AT BASE OF SLOPE TO REINFORCE THE TOE. KEYWAY DEPTH SHOULD BE 1.5 TIMES THE DESIGN THICKNESS OF RIPRAP AND SHOULD "EXTEND A HORIZONTAL DISTANCE EQUAL TO THE DESIGN THICKNESS."
ROCK AND/OR GRAVEL USED FOR FILTER AND RIPRAP SHALL CONFORM TO THE SPECIFIED GRADATION. VOIDS IN THE ROCK RIPRAP SHOULD BE FILLED WITH SPALLS AND SMALLER ROCKS.

FILTER
INSTALL SYNTHETIC FILTER FABRIC OR A SAND/GRAVEL FILTER ON SUBGRADE.
SYNTHETIC FILTER FABRIC
PLACE FILTER FABRIC ON A SMOOTH FOUNDATION. OVERLAP EDGES AT LEAST 12 INCHES, WITH ANCHOR PINS SPACED EVERY 3 FT ALONG OVERLAP. FOR LARGE STONES, A 4-INCH LAYER OF SAND MAY BE NEEDED TO PROTECT FILTERCLOTH.

GEOTEXTILE FABRICS SHOULD BE PROTECTED FROM PUNCTURE OR TEARING DURING PLACEMENT OF THE ROCK RIPRAP BY PLACING A CUSHION OF SAND AND GRAVEL OVER THE FABRIC. DAMAGED AREAS IN THE FABRIC SHOULD BE REPAIRED BY PLACING A PIECE OF FABRIC OVER THE DAMAGED AREA OR BY COMPLETE REPLACEMENT OF THE FABRIC. ALL OVERLAPS REQUIRED FOR REPAIRS OR JOINING TWO PIECES OF FABRIC SHOULD BE A MINIMUM OF 12 INCHES.

SAND/GRAVEL FILTER
SPREAD WELL-GRADED AGGREGATE IN A UNIFORM LAYER TO THE REQUIRED THICKNESS (6 INCHES MINIMUM). IF TWO OR MORE LAYERS ARE SPECIFIED, PLACE THE LAYER OF SMALLER STONES FIRST AND AVOID MIXING THE LAYERS.

STONE PLACEMENT
PLACE RIPRAP IMMEDIATELY AFTER INSTALLING FILTER.
INSTALL RIPRAP TO FULL THICKNESS IN ONE OPERATION. DO NOT DUMP THROUGH CHUTES OR USE ANY METHOD THAT CAUSES SEGREGATION OF STONE SIZES. AVOID DISLODGING OR DAMAGING UNDERLYING FILTER MATERIAL WHEN PLACING STONE.
IF FABRIC IS DAMAGED, REMOVE RIPRAP AND REPAIR FABRIC BY ADDING ANOTHER LAYER, OVERLAPPING THE DAMAGED AREA BY 12 INCHES.
PLACE SMALLER STONES IN VOIDS TO FORM A DENSE, UNIFORM, WELL-GRADED MASS. SELECTIVE LOADING AT THE QUARRY AND SOME HAND PLACEMENT MAY BE NECESSARY TO OBTAIN AN EVEN DISTRIBUTION OF STONE SIZES.
BLEND THE STONE SURFACE SMOOTHLY WITH THE SURROUNDING AREA ALLOWING NO PROTRUSIONS OR OVERFALL.
SINCE RIPRAP IS USED WHERE EROSION POTENTIAL IS HIGH, CONSTRUCTION MUST BE SEQUENCED SO THAT THE RIPRAP IS PUT IN PLACE WITH THE MINIMUM POSSIBLE DELAY. DISTURBANCE OF AREAS WHERE RIPRAP IS TO BE PLACED SHOULD BE UNDERTAKEN ONLY WHEN FINAL PREPARATION AND PLACEMENT OF THE RIPRAP CAN FOLLOW IMMEDIATELY BEHIND THE INITIAL DISTURBANCE.
WHERE RIPRAP IS USED FOR OUTLET PROTECTION, THE RIPRAP SHOULD BE PLACED BEFORE OR IN CONJUNCTION WITH THE CONSTRUCTION OF THE PIPE OR CHANNEL.

MAINTENANCE
RIPRAP SHOULD BE CHECKED AT LEAST ANNUALLY AND AFTER EVERY MAJOR STORM FOR DISPLACED STONES, SLUMPING, AND EROSION AT EDGES, ESPECIALLY DOWNSTREAM OR DOWNSLOPE. IF THE RIPRAP HAS BEEN DAMAGED, IT SHOULD BE REPAIRED IMMEDIATELY BEFORE FURTHER DAMAGE CAN TAKE PLACE.
WOODY VEGETATION SHOULD BE REMOVED FROM THE ROCK RIPRAP ANNUALLY BECAUSE TREE ROOTS WILL EVENTUALLY DISLodge THE RIPRAP.
IF THE RIPRAP IS ON A CHANNEL BANK, THE STREAM SHOULD BE KEPT CLEAR OF OBSTRUCTIONS SUCH AS FALLEN TREES, DEBRIS, AND SEDIMENT BARS THAT MAY CHANGE FLOW PATTERNS WHICH COULD DAMAGE OR DISPLACE THE RIPRAP.

RIP RAP
SCALE: N.T.S.



PERMITTING SET
ISSUED: 10/23/2020
NOT TO BE USED FOR CONSTRUCTION



EROSION AND SEDIMENT CONTROL NOTES - 2 OF 3
STATE PIER INFRASTRUCTURE IMPROVEMENTS
STATE PIER FACILITY - NEW LONDON, CT

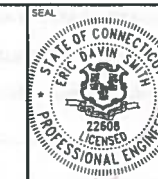

Digitally signed by
Eric D Smith
DN: c=US,
o=Unaffiliated,
ou=A01410C000001
71CC9B22C1000095
D6, cn=Eric D Smith
Date: 2020.10.27
10:07:21 -04'00'

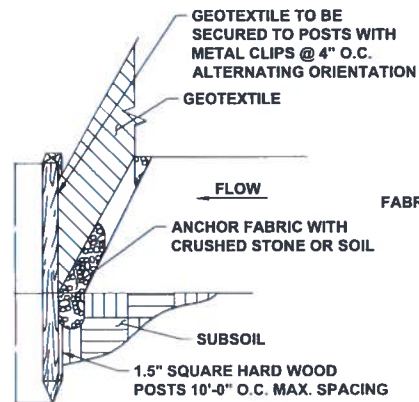

SILT FENCE

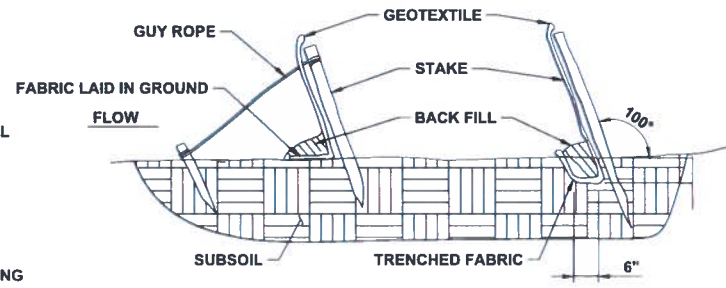

BACK FILL OR TRENCH FABRIC TOE

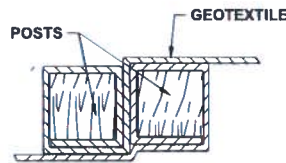

FENCE JOINT PLAN VIEW

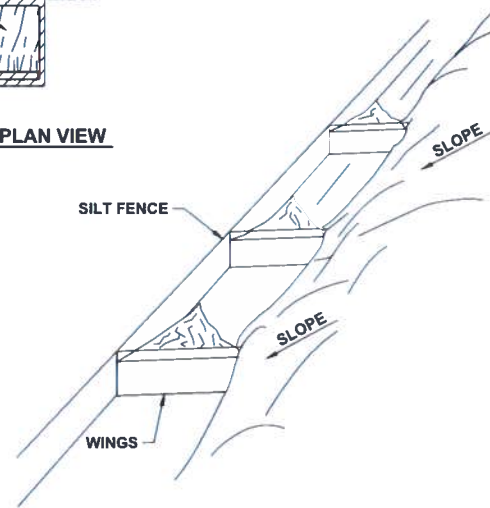

SILT FENCE SYSTEM PLACEMENT ON TOE OF SLOPE

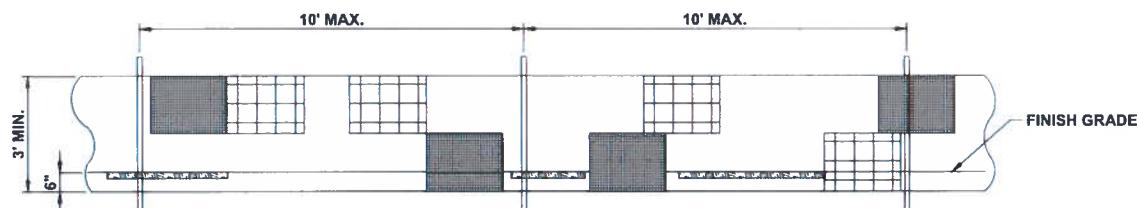

ELEVATION VIEW

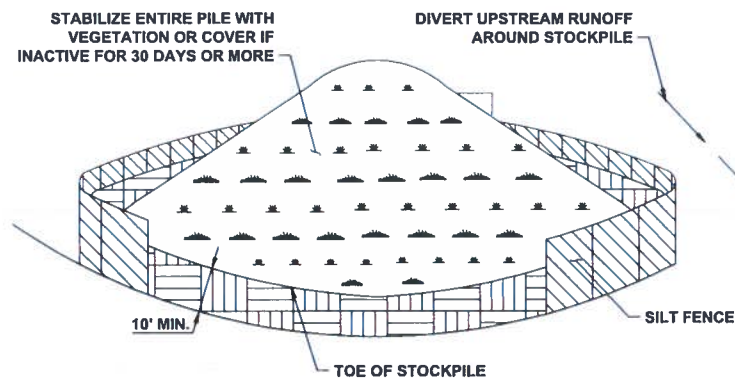

TEMPORARY SOIL STOCKPILING NOTES:

1. AREA CHOSEN FOR STOCKPILING OPERATIONS SHALL BE DRY AND STABLE.
2. MAXIMUM SLOPE OF STOCKPILE SHALL BE 2H:1V.
3. UPON COMPLETION OF SOIL STOCKPILING, EACH PILE SHALL BE SURROUNDED WITH EITHER SILT FENCING OR HAY BALES, THEN STABILIZED WITH VEGETATION OR COVERED WITH POLYETHYLENE SHEETING AND SANDBAGS.
4. A POLYETHYLENE MEMBRANE UNDERLAYMENT MAY BE REQUIRED PER ENGINEER REQUESTS.

TEMPORARY SOIL STOCKPILING

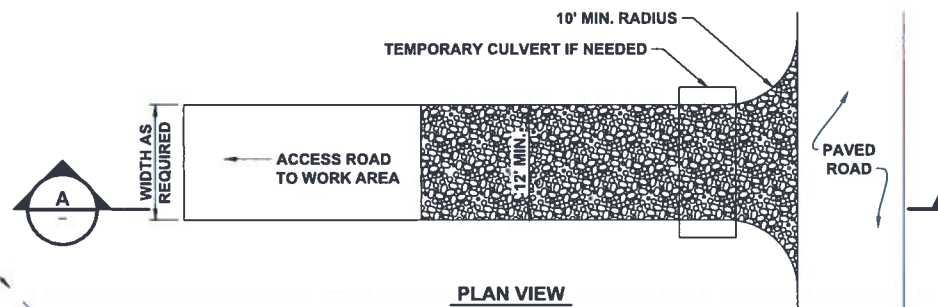

PLAN VIEW

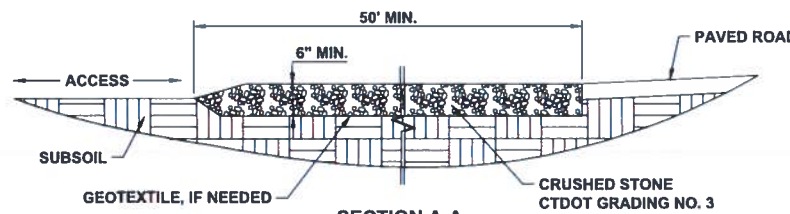

SECTION A-A

CONSTRUCTION ENTRANCE NOTES:

1. TOPSOIL AND ORGANICS SHOULD BE REMOVED PRIOR TO INSTALLATION.
2. CONSTRUCTION ENTRANCE TO BE LOCATED WHERE ACCESS ROAD MEETS PAVED ACCESS/DRIVEWAY.
3. AFTER CONSTRUCTION, ANY DEBRIS SHOULD BE CLEARED FROM THE TRACKING PAD, THE PAD RE-LEVELLED AND 2'-4" OF 3/4" CRUSHED GRAVEL SHOULD BE ADDED TO FILL VOIDS AND CREATE A SMOOTH SURFACE WITH A 2% CROWN OR CROSS-SLOPE.

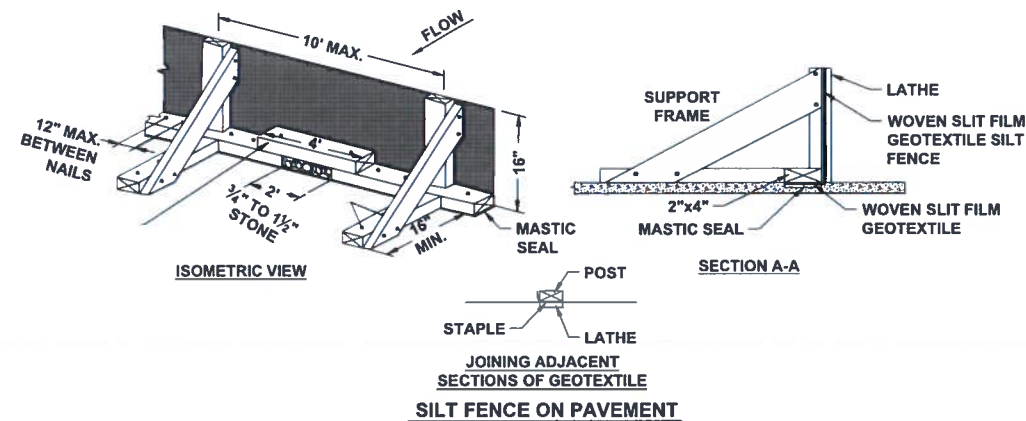

CONSTRUCTION SPECIFICATIONS

1. USE NOMINAL 2 INCH X 4 INCH LUMBER.
2. USE WOVEN SLIT FILM GEOTEXTILE, SUCH AS POLYPROPYLENE, NYLON, POLYESTER, ETHYLENE, OR APPROVED SIMILAR MATERIAL.
3. PROVIDE MANUFACTURER CERTIFICATION TO THE AUTHORIZED REPRESENTATIVE OF THE INSPECTION/ENFORCEMENT AUTHORITY SHOWING THAT THE GEOTEXTILE USED MEETS THE REQUIREMENTS.
4. SPACE UPRIGHT SUPPORTS NO MORE THAN 10 FEET APART.
5. PROVIDE A TWO FOOT OPENING BETWEEN EVERY SET OF SUPPORTS AND PLACE STONE IN THE OPENING OVER GEOTEXTILE.
6. KEEP SILT FENCE TAUT AND SECURELY STAPLE TO THE UPSLOPE SIDE OF UPRIGHT SUPPORTS. EXTEND GEOTEXTILE UNDER 2x4.
7. WHERE TWO SECTIONS OF GEOTEXTILE ADJOIN: OVERLAP, FOLD, AND STAPLE TO POST IN ACCORDANCE WITH THIS DETAIL. ATTACH LATHE.
8. PROVIDE A MASTIC SEAL BETWEEN PAVEMENT, GEOTEXTILE, AND 2x4 TO PREVENT SEDIMENT-LADEN WATER FROM ESCAPING BENEATH SILT FENCE INSTALLATION.
9. SECURE BOARDS TO PAVEMENT WITH 40D 5 INCH MINIMUM LENGTH NAILS.
10. REMOVE ACCUMULATED SEDIMENT AND DEBRIS WHEN BULGES DEVELOP IN SILT FENCE OR WHEN SEDIMENT REACHES 25% OF FENCE HEIGHT. REPLACE GEOTEXTILE IF TORN. MAINTAIN WATER TIGHT SEAL ALONG BOTTOM. REPLACE STONE IF DISPLACED.

GEOTEXTILE SILT FENCE NOTES:

1. GEOTEXTILE FENCE SHOULD BE PLACED SO THE FENCE LEANS TOWARD THE SOURCE OF SEDIMENT.
2. MAXIMUM SPACING FOR WOODEN STAKES OR STEEL POSTS IS 10'-0".
3. WOOD STAKES SHALL HAVE A MINIMUM CROSS-SECTION SIZE OF 1.5"x1.5" AND A MINIMUM LENGTH OF 3'-6". SILT FENCE SUBJECT TO HEAVY LOADS SHALL BE REINFORCED WITH STEEL POSTS AT LEAST 0.5 LB. PER FOOT WITH A MINIMUM LENGTH OF 4 FT.
4. WOODEN STAKES OR STEEL POSTS SHALL BE DRIVEN TO A MINIMUM OF 12" INTO THE GROUND.
5. 6" OF GEOTEXTILE SHALL BE BURIED BY BACK FILLING OR TRENCHING AND AT LEAST 30" IN HEIGHT OF GEOTEXTILE SHALL BE EXPOSED.
6. FABRIC SHALL BE JOINED ONLY AT A SUPPORT POST WITH A MINIMUM OF 6" OVERLAP AND SECURELY SEALED.
7. UPON REESTABLISHMENT OF GROUND COVER IN DISTURBED AREAS AND WHEN DIRECTED BY THE ENGINEER OR UPON FINAL INSPECTION, FENCE AND ANY SEDIMENT SHALL BE REMOVED. AT NO TIME WILL THE FENCE REMAIN IN PLACE AFTER PROJECT COMPLETION.
8. GEOTEXTILE FENCE SHALL NOT BE USED IN A WATER COURSE.
9. ONLY GEOTEXTILE FROM THE DEPARTMENTS APPROVED PRODUCT LIST SHALL BE USED.
10. BACK FILLING OF GEOTEXTILE SHALL ONLY BE USED WHEN GROUND IS FROZEN OR WHERE OTHER OBSTRUCTIONS ARE ENCOUNTERED THAT PROHIBIT TRENCHING; E.G., STUMPS OR ROCKS.
11. CLEAN OUT ACCUMULATED SEDIMENT WHEN ONE-HALF OF THE ORIGINAL HEIGHT OF THE GEOTEXTILE FENCE BECOMES FILLED WITH SEDIMENT OR AS DIRECTED BY THE ENGINEER.
12. POSITION POSTS TO OVERLAP MAKING CERTAIN THAT FABRIC FOLDS AROUND EACH POST ONE FULL TURN.
13. DRIVE POSTS TIGHTLY TOGETHER AND SECURE TOPS OF POSTS BY TYING OFF WITH CORD OR WIRE TO PREVENT FLOW-THROUGH OF BUILT-UP SEDIMENT AT JOINTS.
14. WHEN USING SILT FENCE ALONG TOE OF SLOPE, ADD WINGS TO PREVENT SEDIMENT FROM MOVING ALONG THE FENCE AND OFF THE SITE.

DWG INFO: C:\BOS\Projects\10630\Detail Design\State Pier\10630-07.dwg, May 4, 2020 - 3:03 PM, CHUY/AGLESAS, (C) MOFFATT AND NICHOL

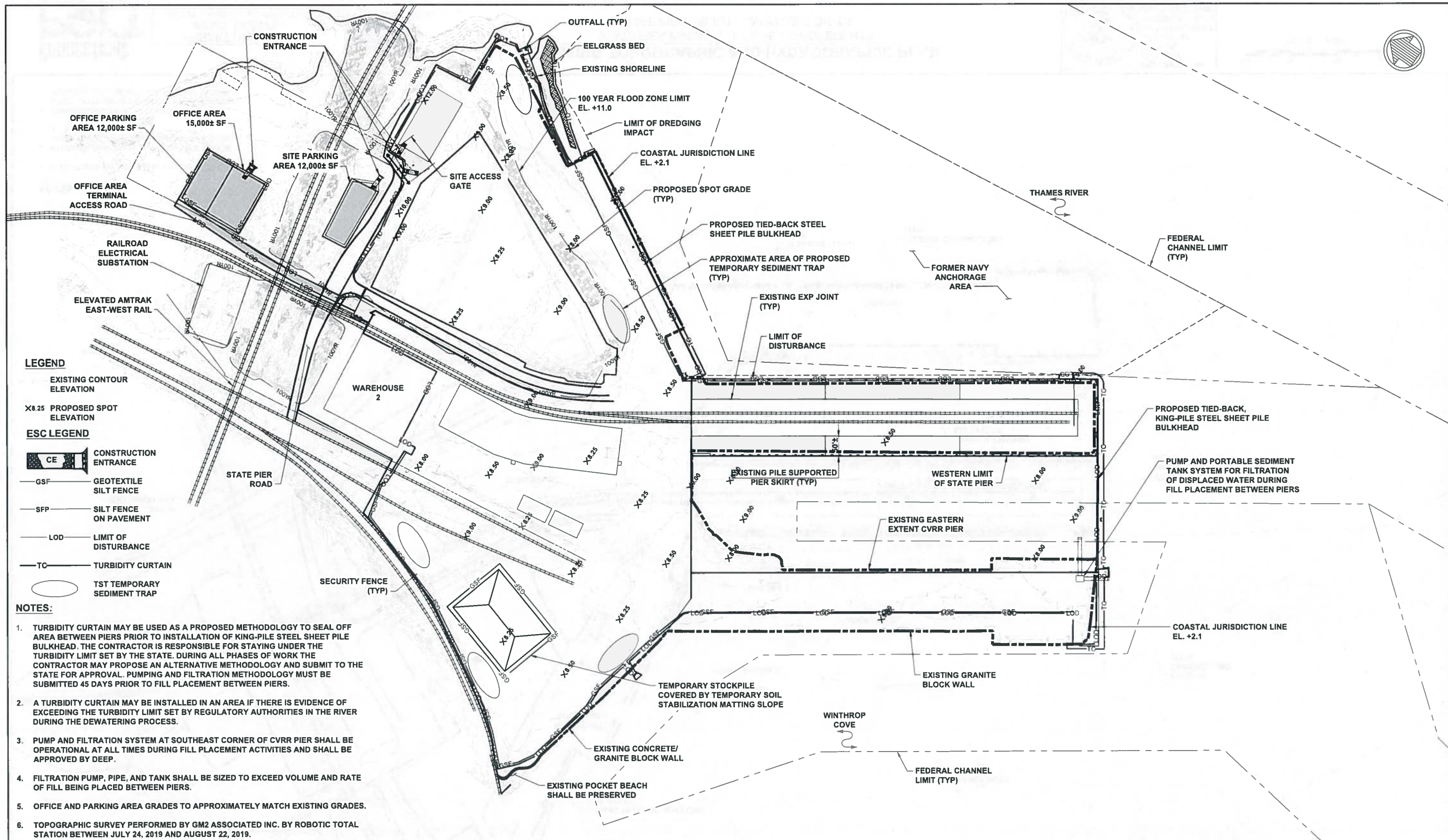

LEGEND

- EXISTING CONTOUR ELEVATION
- X8.25 PROPOSED SPOT ELEVATION

ESC LEGEND

- CONSTRUCTION ENTRANCE
- GEOTEXTILE SILT FENCE
- SILT FENCE ON PAVEMENT
- LIMIT OF DISTURBANCE
- TURBIDITY CURTAIN
- TST TEMPORARY SEDIMENT TRAP

NOTES:

1. TURBIDITY CURTAIN MAY BE USED AS A PROPOSED METHODOLOGY TO SEAL OFF AREA BETWEEN PIERS PRIOR TO INSTALLATION OF KING-PILE STEEL SHEET PILE BULKHEAD. THE CONTRACTOR IS RESPONSIBLE FOR STAYING UNDER THE TURBIDITY LIMIT SET BY THE STATE. DURING ALL PHASES OF WORK THE CONTRACTOR MAY PROPOSE AN ALTERNATIVE METHODOLOGY AND SUBMIT TO THE STATE FOR APPROVAL. PUMPING AND FILTRATION METHODOLOGY MUST BE SUBMITTED 45 DAYS PRIOR TO FILL PLACEMENT BETWEEN PIERS.
2. A TURBIDITY CURTAIN MAY BE INSTALLED IN AN AREA IF THERE IS EVIDENCE OF EXCEEDING THE TURBIDITY LIMIT SET BY REGULATORY AUTHORITIES IN THE RIVER DURING THE DEWATERING PROCESS.
3. PUMP AND FILTRATION SYSTEM AT SOUTHEAST CORNER OF CVRR PIER SHALL BE OPERATIONAL AT ALL TIMES DURING FILL PLACEMENT ACTIVITIES AND SHALL BE APPROVED BY DEEP.
4. FILTRATION PUMP, PIPE, AND TANK SHALL BE SIZED TO EXCEED VOLUME AND RATE OF FILL BEING PLACED BETWEEN PIERS.
5. OFFICE AND PARKING AREA GRADES TO APPROXIMATELY MATCH EXISTING GRADES.
6. TOPOGRAPHIC SURVEY PERFORMED BY GM2 ASSOCIATED INC. BY ROBOTIC TOTAL STATION BETWEEN JULY 24, 2019 AND AUGUST 22, 2019.



PERMITTING SET
ISSUED: 10/23/2020
NOT TO BE USED FOR CONSTRUCTION



EROSION AND SEDIMENT CONTROL PLAN
STATE PIER INFRASTRUCTURE IMPROVEMENTS
STATE PIER FACILITY - NEW LONDON, CT



Digitally signed by
Eric D Smith
DN: c=US,
o=Unaffiliated,
ou=A01410C000001
71CC9B22C1000095
D6, cn=Eric D Smith
Date: 2020.10.27
10:14:01 -04'00'



DWG INFO: C:\BOS\Projects\10630\Detail Design\State Pier\1500 CAD\DWG\PermitSet\10630-08.dwg, May 1, 2020, 1:35 PM, CHAOYANGLESAS, (C) MOFFATT AND NICHOL

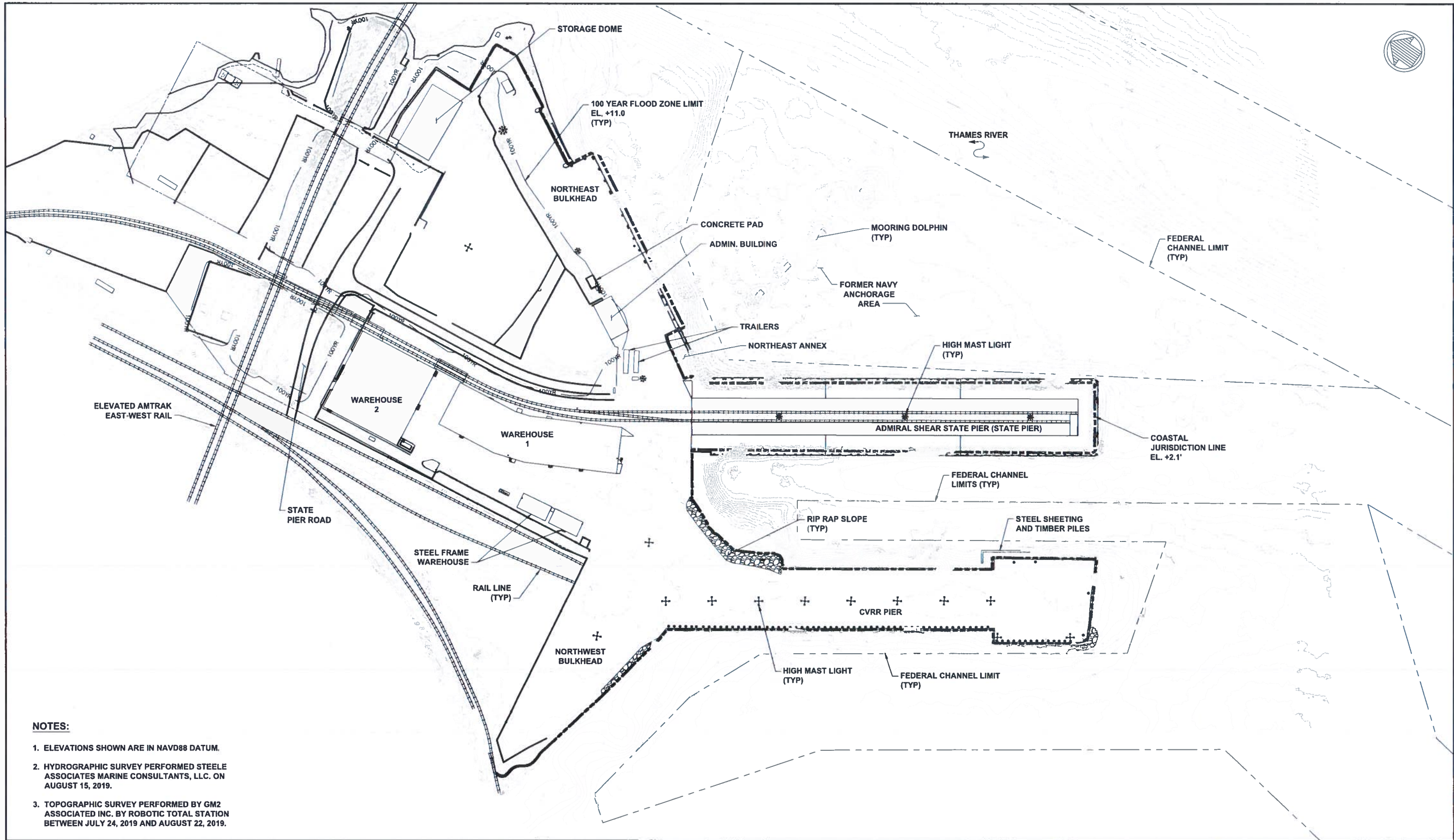

NOTES:

- 1. ELEVATIONS SHOWN ARE IN NAVD88 DATUM.
- 2. HYDROGRAPHIC SURVEY PERFORMED STEELE ASSOCIATES MARINE CONSULTANTS, LLC. ON AUGUST 15, 2019.
- 3. TOPOGRAPHIC SURVEY PERFORMED BY GM2 ASSOCIATED INC. BY ROBOTIC TOTAL STATION BETWEEN JULY 24, 2019 AND AUGUST 22, 2019.



PERMITTING SET
ISSUED: 10/23/2020
NOT TO BE USED FOR CONSTRUCTION



EXISTING TOPOGRAPHIC AND HYDROGRAPHIC PLAN
STATE PIER INFRASTRUCTURE IMPROVEMENTS
STATE PIER FACILITY - NEW LONDON, CT



Digitally signed by
Eric D Smith
DN: c=US,
ou=Unaffiliated,
ou=A01410C000001
71CC9B22C1000095
D6, cn=Eric D Smith
Date: 2020.10.27
10:16:56 -04'00'



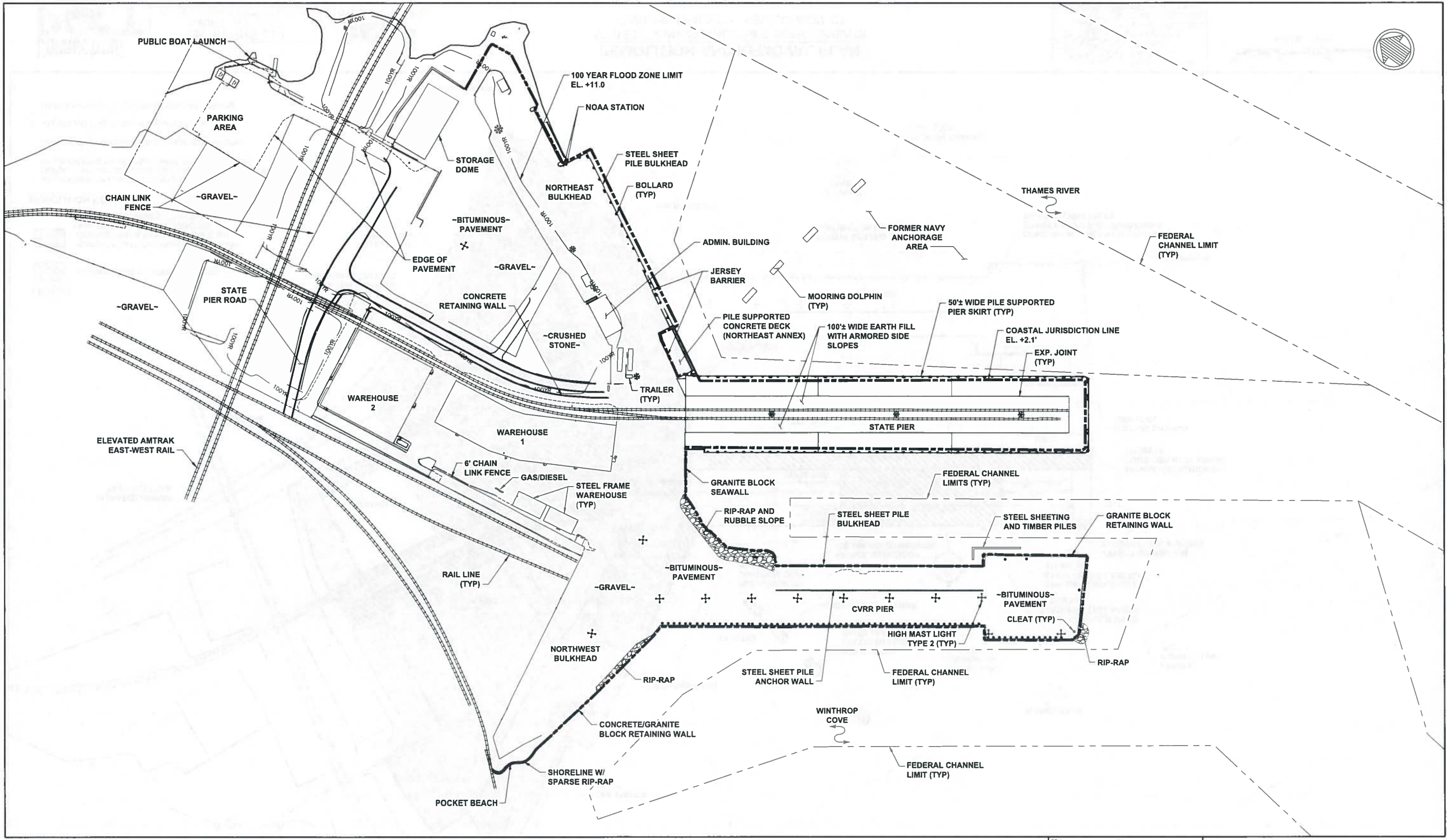

DWG INFO: Q:\LIBS\Projects\10630 Detail Design State pier\100 CAD\DWG_Active_PermitSet\10630-09.dwg, April 28, 2020 - 2:32 PM, C:\NOV\ANGLES\AS (C) MOFFATT AND NICHOL



PERMITTING SET
 ISSUED: 10/23/2020
 NOT TO BE USED FOR CONSTRUCTION



EXISTING CONDITIONS PLAN
 STATE PIER INFRASTRUCTURE IMPROVEMENTS
 STATE PIER FACILITY - NEW LONDON, CT

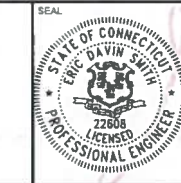



Digitally signed by
 Eric D Smith
 DN: c=US,
 o=Unaffiliated,
 ou=A01410C000001
 71CC9B22C1000095
 D6, cn=Eric D Smith
 Date: 2020.10.27
 10:20:18 -04'00'

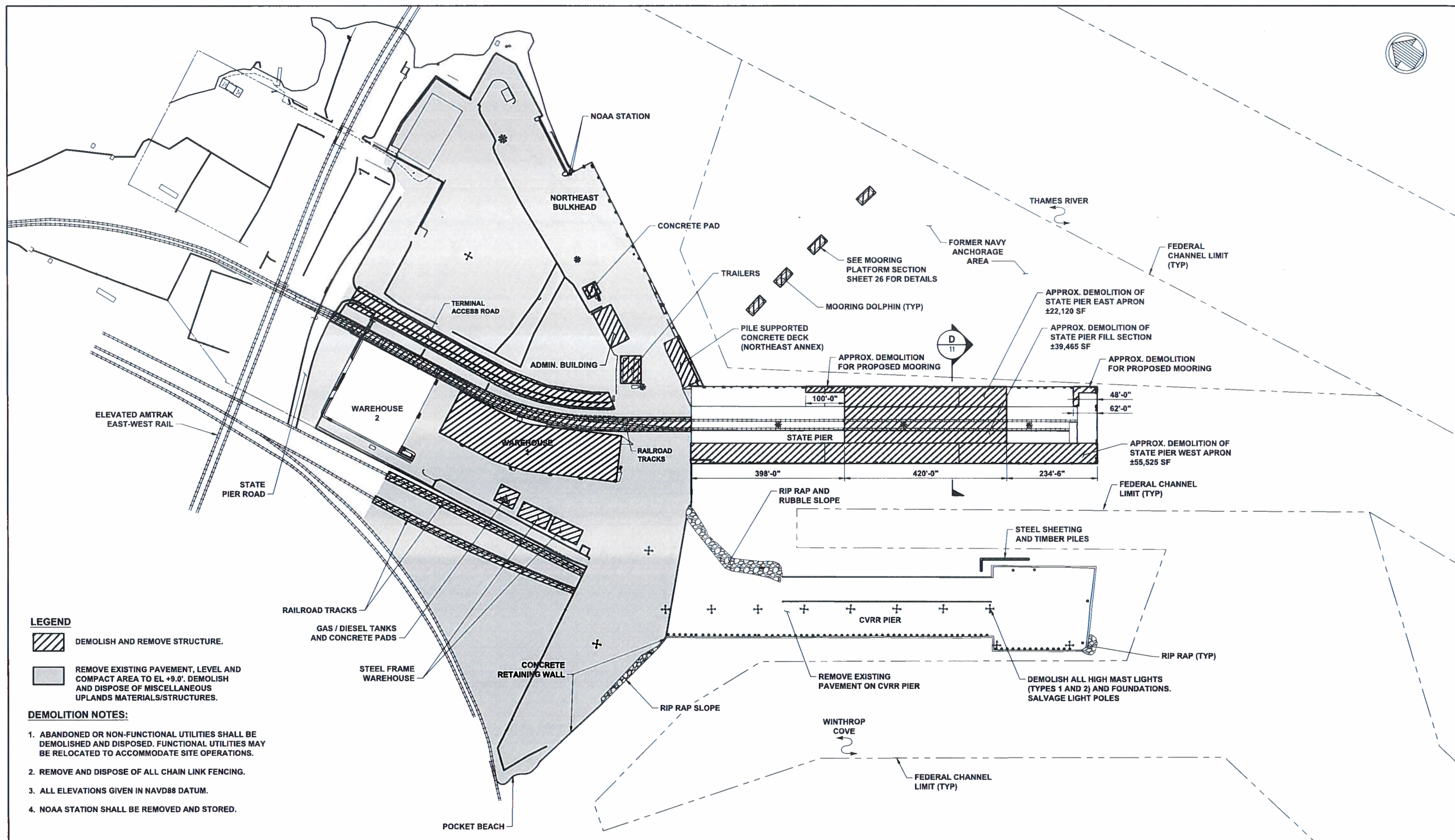

DWG INFO: C:\BOS\Projects\1630 Dredg\Drawn\PermitSet\10630-10.dwg, October 15, 2020 - 8:17 PM, CADYNGLESJAS, (C) MOFFATT AND NICHOL



LEGEND

-  DEMOLISH AND REMOVE STRUCTURE.
-  REMOVE EXISTING PAVEMENT, LEVEL AND COMPACT AREA TO EL. +9.0'. DEMOLISH AND DISPOSE OF MISCELLANEOUS UPLANDS MATERIALS/STRUCTURES.

DEMOLITION NOTES:

1. ABANDONED OR NON-FUNCTIONAL UTILITIES SHALL BE DEMOLISHED AND DISPOSED. FUNCTIONAL UTILITIES MAY BE RELOCATED TO ACCOMMODATE SITE OPERATIONS.
2. REMOVE AND DISPOSE OF ALL CHAIN LINK FENCING.
3. ALL ELEVATIONS GIVEN IN NAVD88 DATUM.
4. NOAA STATION SHALL BE REMOVED AND STORED.



PERMITTING SET
ISSUED: 10/23/2020
NOT TO BE USED FOR CONSTRUCTION



DEMOLITION AND REMOVAL PLAN
STATE PIER INFRASTRUCTURE IMPROVEMENTS
STATE PIER FACILITY - NEW LONDON, CT



Digitally signed by
Eric D Smith
DN: c=US,
o=Unaffiliated,
ou=A01410C000001
71CC9B22C1000095
D6, cn=Eric D Smith
Date: 2020.10.27
10:22:59 -04'00'

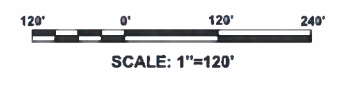

DWG INFO: Q:\BOS\Projects\10630 Detail Design State pier\500 CADD\ Activel PermiSet\10630-11.dwg May 4, 2020 - 7:24 PM CHOYANGLESAS, (C) MOFFATT AND NICHOL

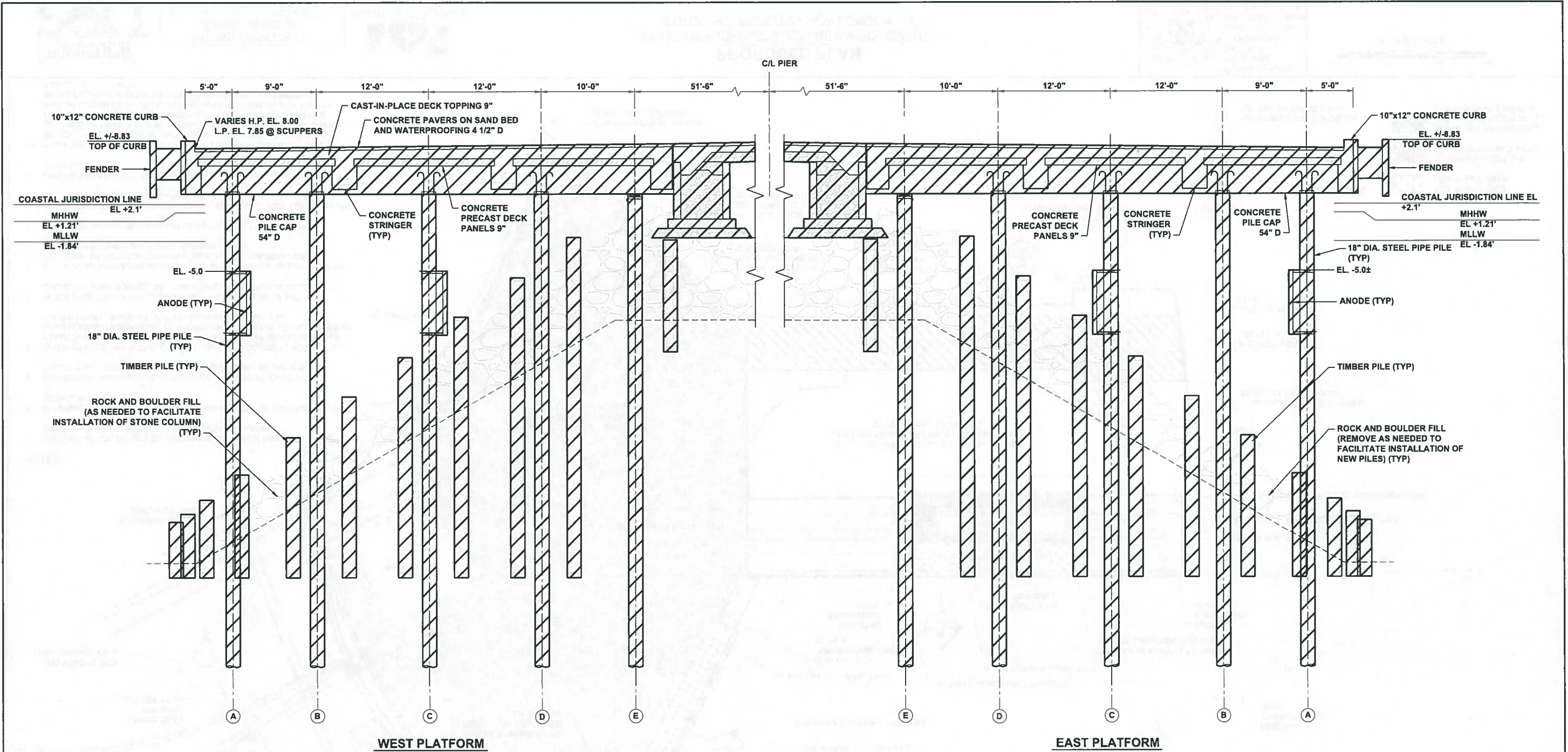

D SECTION
SCALE: 3/16" = 1'-0"

- NOTE:**
1. ALL BOLLARDS AND FENDER SYSTEMS SHALL BE SALVAGED AND STORED AS DIRECTED BY OWNER.
 2. STEEL PIPE AND TIMBER PILES ARE TO BE REMOVED VIA VIBRO-HAMMER

LEGEND

DEMOLISH AND REMOVE STRUCTURE



PERMITTING SET
ISSUED: 10/23/2020
NOT TO BE USED FOR CONSTRUCTION



EXISTING STATE PIER PILE SUPPORTED PLATFORM
STATE PIER INFRASTRUCTURE IMPROVEMENTS
STATE PIER FACILITY - NEW LONDON, CT

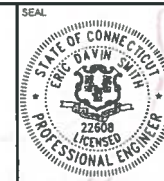

Digitally signed by Eric D Smith
DN: c=US, o=Unaffiliated, ou=A01410C00000171CC9B22C1000095D6, cn=Eric D Smith
Date: 2020.10.27 10:25:39 -04'00'

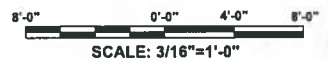

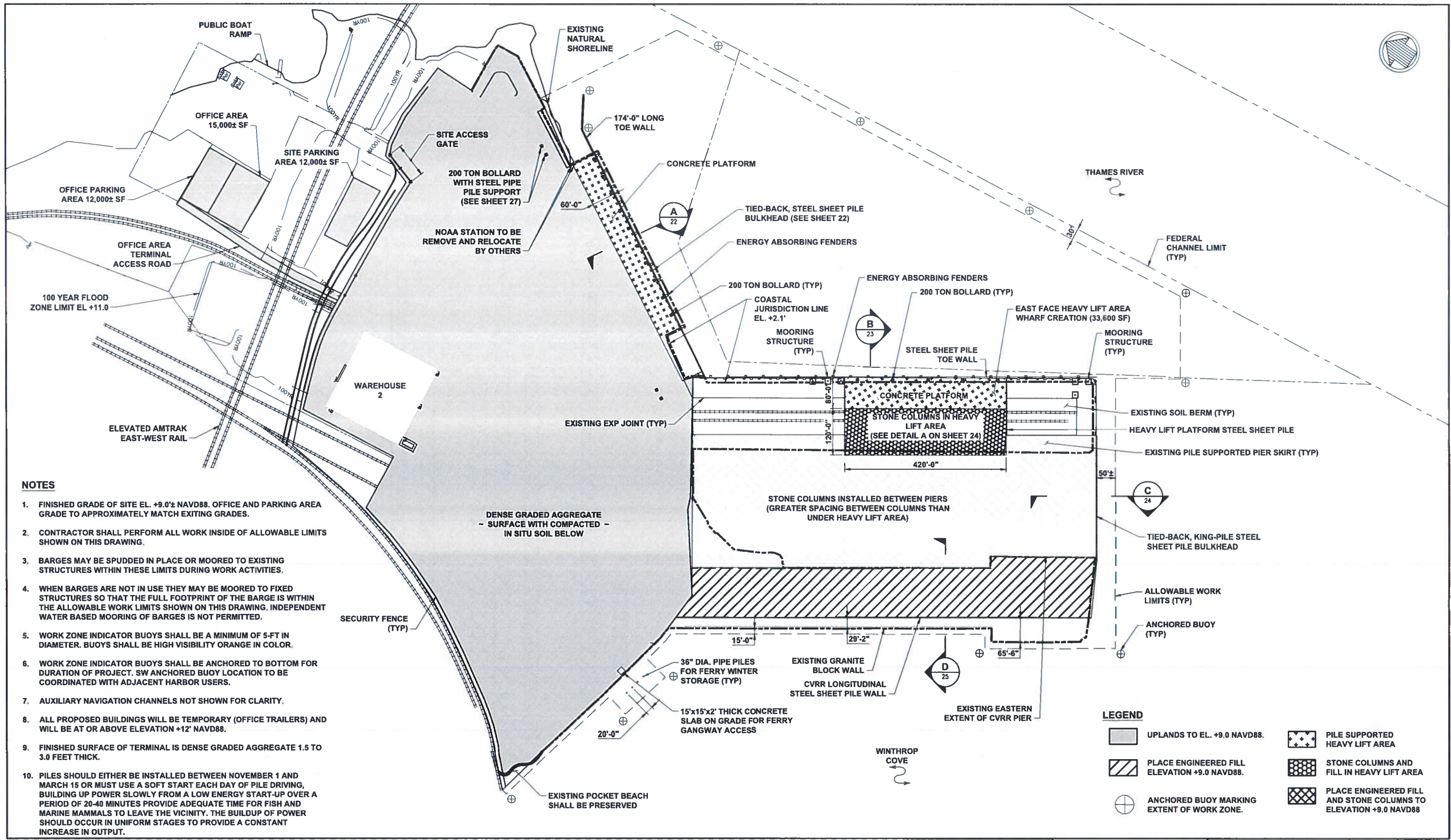

- NOTES**
1. FINISHED GRADE OF SITE EL. +9.0'± NAVD88. OFFICE AND PARKING AREA GRADE TO APPROXIMATELY MATCH EXISTING GRADES.
 2. CONTRACTOR SHALL PERFORM ALL WORK INSIDE OF ALLOWABLE LIMITS SHOWN ON THIS DRAWING.
 3. BARGES MAY BE SPUNDED IN PLACE OR MOORED TO EXISTING STRUCTURES WITHIN THESE LIMITS DURING WORK ACTIVITIES.
 4. WHEN BARGES ARE NOT IN USE THEY MAY BE MOORED TO FIXED STRUCTURES SO THAT THE FULL FOOTPRINT OF THE BARGE IS WITHIN THE ALLOWABLE WORK LIMITS SHOWN ON THIS DRAWING. INDEPENDENT WATER BASED MOORING OF BARGES IS NOT PERMITTED.
 5. WORK ZONE INDICATOR BUOYS SHALL BE A MINIMUM OF 5-FT IN DIAMETER. BUOYS SHALL BE HIGH VISIBILITY ORANGE IN COLOR.
 6. WORK ZONE INDICATOR BUOYS SHALL BE ANCHORED TO BOTTOM FOR DURATION OF PROJECT. SW ANCHORED BUOY LOCATION TO BE COORDINATED WITH ADJACENT HARBOR USERS.
 7. AUXILIARY NAVIGATION CHANNELS NOT SHOWN FOR CLARITY.
 8. ALL PROPOSED BUILDINGS WILL BE TEMPORARY (OFFICE TRAILERS) AND WILL BE AT OR ABOVE ELEVATION +12' NAVD88.
 9. FINISHED SURFACE OF TERMINAL IS DENSE GRADED AGGREGATE 1.5 TO 3.0 FEET THICK.
 10. PILES SHOULD EITHER BE INSTALLED BETWEEN NOVEMBER 1 AND MARCH 15 OR MUST USE A SOFT START EACH DAY OF PILE DRIVING, BUILDING UP POWER SLOWLY FROM A LOW ENERGY START-UP OVER A PERIOD OF 20-40 MINUTES PROVIDE ADEQUATE TIME FOR FISH AND MARINE MAMMALS TO LEAVE THE VICINITY. THE BUILDUP OF POWER SHOULD OCCUR IN UNIFORM STAGES TO PROVIDE A CONSTANT INCREASE IN OUTPUT.

LEGEND

	UPLANDS TO EL. +9.0 NAVD88.		PILE SUPPORTED HEAVY LIFT AREA
	PLACE ENGINEERED FILL ELEVATION +9.0 NAVD88.		STONE COLUMNS AND FILL IN HEAVY LIFT AREA
	ANCHORED BUOY MARKING EXTENT OF WORK ZONE.		PLACE ENGINEERED FILL AND STONE COLUMNS TO ELEVATION +9.0 NAVD88



PERMITTING SET
ISSUED: 10/23/2020
NOT TO BE USED FOR CONSTRUCTION



PROPOSED PLAN
STATE PIER INFRASTRUCTURE IMPROVEMENTS
STATE PIER FACILITY - NEW LONDON, CT



Digitally signed by
Eric D Smith
DN: c=US,
o=Unaffiliated,
ou=A01410C000001
71CC9B22C1000095
D6, cn=Eric D Smith
Date: 2020.10.27
10:30:00 -04'00'



DWG INFO: C:\BOS\Projects\1630-Dredal Design\State pier\500 CAD\DWG_Acct\PermitSet\1630-12.dwg, October 20, 2020 - 2:46 PM, AMBRANDA, (C) MOFFATT AND NICHOL

DWG INFO: Q:\BOS\Projects\10530 Detail Design State pier\10530-13.dwg; October 20, 2020 - 2:46 PM; MAMPANDA, (C) MOFFATT AND NICHOL

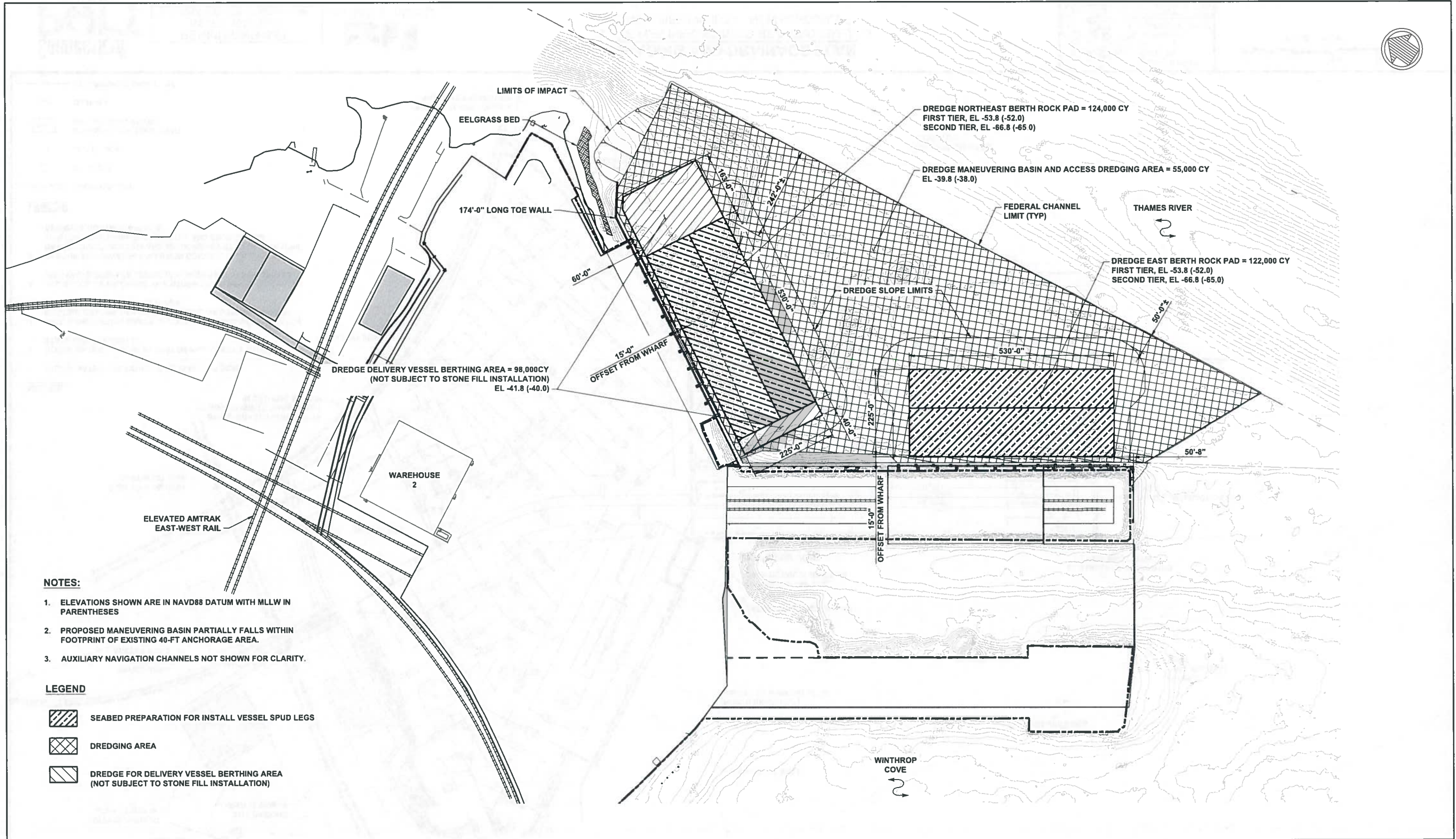

NOTES:

1. ELEVATIONS SHOWN ARE IN NAVD88 DATUM WITH MLLW IN PARENTHESES
2. PROPOSED MANEUVERING BASIN PARTIALLY FALLS WITHIN FOOTPRINT OF EXISTING 40-FT ANCHORAGE AREA.
3. AUXILIARY NAVIGATION CHANNELS NOT SHOWN FOR CLARITY.

LEGEND

- SEABED PREPARATION FOR INSTALL VESSEL SPUD LEGS
- DREDGING AREA
- DREDGE FOR DELIVERY VESSEL BERTHING AREA (NOT SUBJECT TO STONE FILL INSTALLATION)



PERMITTING SET
 ISSUED: 10/23/2020
 NOT TO BE USED FOR CONSTRUCTION



PROPOSED DREDGING PLAN
 STATE PIER INFRASTRUCTURE IMPROVEMENTS
 STATE PIER FACILITY - NEW LONDON, CT

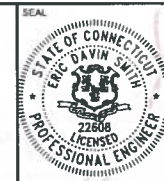

Digitally signed by
 Eric D Smith
 DN: c=US,
 o=Unaffiliated,
 ou=A01410C000001
 71CC9B22C1000095
 D6, cn=Eric D Smith
 Date: 2020.10.27
 10:34:49 -04'00'



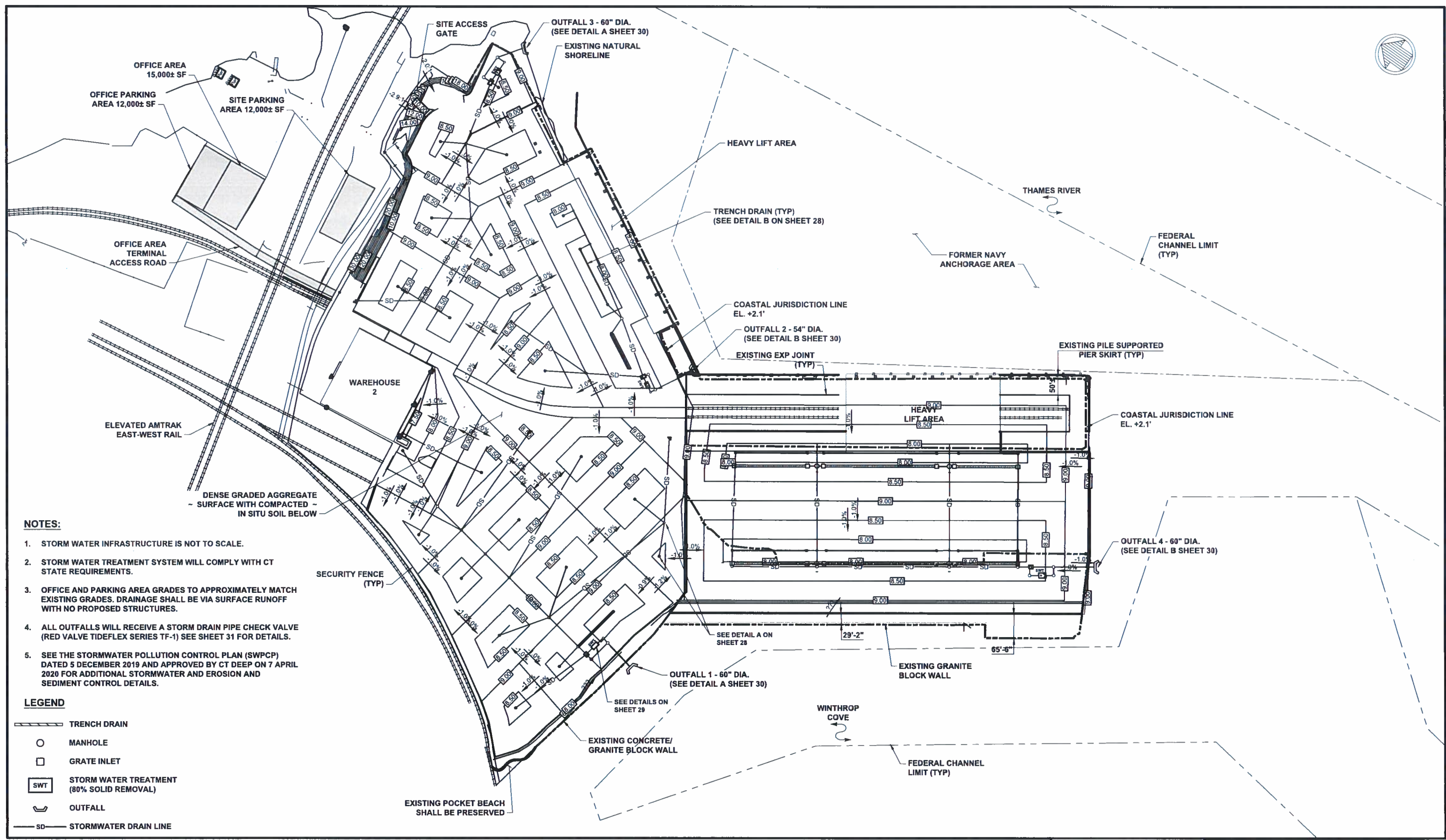

- NOTES:**
1. STORM WATER INFRASTRUCTURE IS NOT TO SCALE.
 2. STORM WATER TREATMENT SYSTEM WILL COMPLY WITH CT STATE REQUIREMENTS.
 3. OFFICE AND PARKING AREA GRADES TO APPROXIMATELY MATCH EXISTING GRADES. DRAINAGE SHALL BE VIA SURFACE RUNOFF WITH NO PROPOSED STRUCTURES.
 4. ALL OUTFALLS WILL RECEIVE A STORM DRAIN PIPE CHECK VALVE (RED VALVE TIDFLEX SERIES TF-1) SEE SHEET 31 FOR DETAILS.
 5. SEE THE STORMWATER POLLUTION CONTROL PLAN (SWPCP) DATED 5 DECEMBER 2019 AND APPROVED BY CT DEEP ON 7 APRIL 2020 FOR ADDITIONAL STORMWATER AND EROSION AND SEDIMENT CONTROL DETAILS.

- LEGEND**
- TRENCH DRAIN
 - MANHOLE
 - GRATE INLET
 - STORM WATER TREATMENT (80% SOLID REMOVAL)
 - OUTFALL
 - SD - STORMWATER DRAIN LINE



Digitally signed by
Eric D Smith
DN: c=US,
ou=Unaffiliated,
ou=A01410C000001
71CC9B22C1000095
D6, cn=Eric D Smith
Date: 2020.10.27
10:39:41 -04'00'

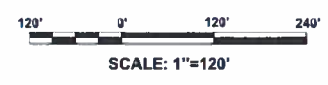

PERMITTING SET
ISSUED: 10/23/2020
NOT TO BE USED FOR CONSTRUCTION



GRADING AND DRAINAGE PLAN
STATE PIER INFRASTRUCTURE IMPROVEMENTS
STATE PIER FACILITY - NEW LONDON, CT

DWG INFO: C:\BSP\Projects\10330\Draw\PermitSet\10330-1.dwg, October 26, 2020, 6:08 PM, P:\DWG\ER, (C) MOFFATT AND NICHOL

DWG INFO: C:\BOS\Projects\10630\Detail Design\State pier\10630-15.dwg; May 4, 2020 - 6:03 PM; CHUYANGLESAS; (C) MOFFATT AND NICHOL

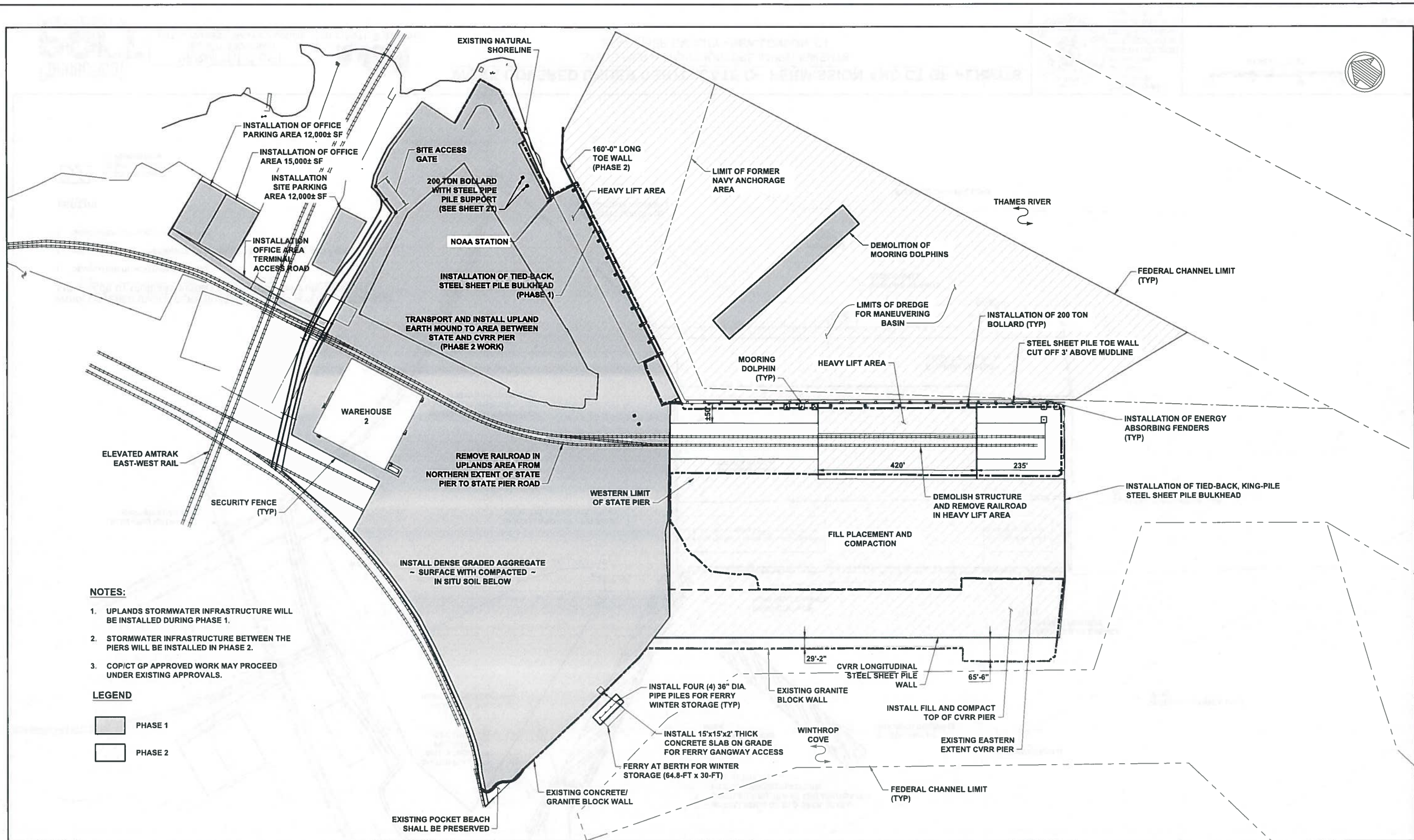

NOTES:

1. UPLANDS STORMWATER INFRASTRUCTURE WILL BE INSTALLED DURING PHASE 1.
2. STORMWATER INFRASTRUCTURE BETWEEN THE PIERS WILL BE INSTALLED IN PHASE 2.
3. COP/CT GP APPROVED WORK MAY PROCEED UNDER EXISTING APPROVALS.

LEGEND

- PHASE 1
- PHASE 2



PERMITTING SET
 ISSUED: 10/23/2020
 NOT TO BE USED FOR CONSTRUCTION



PHASING PLAN
 STATE PIER INFRASTRUCTURE IMPROVEMENTS
 STATE PIER FACILITY - NEW LONDON, CT



Digitally signed by
 Eric D Smith
 DN: c=US,
 o=Unaffiliated,
 ou=A01410C000001
 71CC9B22C1000095
 D6, cn=Eric D Smith
 Date: 2020.10.27
 10:43:03 -04'00'



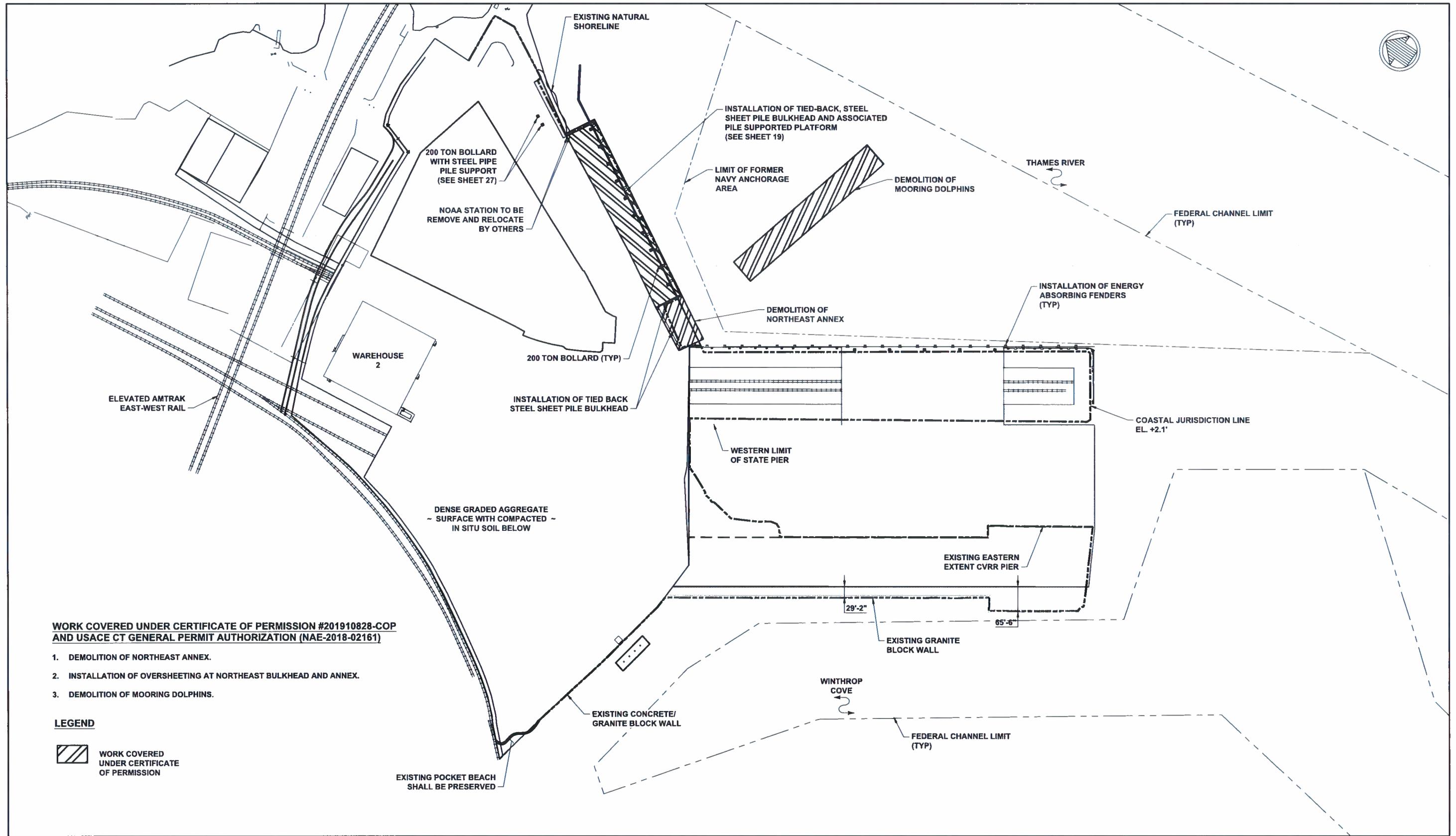

WORK COVERED UNDER CERTIFICATE OF PERMISSION #201910828-COP AND USACE CT GENERAL PERMIT AUTHORIZATION (NAE-2018-02161)

1. DEMOLITION OF NORTHEAST ANNEX.
2. INSTALLATION OF OVERSHEETING AT NORTHEAST BULKHEAD AND ANNEX.
3. DEMOLITION OF MOORING DOLPHINS.

LEGEND

WORK COVERED UNDER CERTIFICATE OF PERMISSION

DWG INFO: C:\BOS\Projects\16630_Design\State pier\16630_CADD\Acad\16630.dwg, May 4, 2020, 5:02 PM, CMYANALESIAS, (C) MOFFATT AND NICHOL



PERMITTING SET
ISSUED: 10/23/2020
NOT TO BE USED FOR CONSTRUCTION



WORK COVERED UNDER CERTIFICATE OF PERMISSION AND CT GP PERMITS
STATE PIER INFRASTRUCTURE IMPROVEMENTS
STATE PIER FACILITY - NEW LONDON, CT



Digitally signed by Eric D Smith
DN: c=US, o=Unaffiliated, ou=A01410C00000171CC9B22C1000095D6, cn=Eric D Smith
Date: 2020.10.27 10:46:10 -04'00'

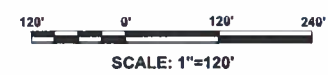

DWG INFO: C:\BOS\Projects\16830\Detail Design\State Pier\16830-17.dwg, May 4, 2020, 1:08 PM, DFRANZESE, (C) MOFFATT AND NICHOL

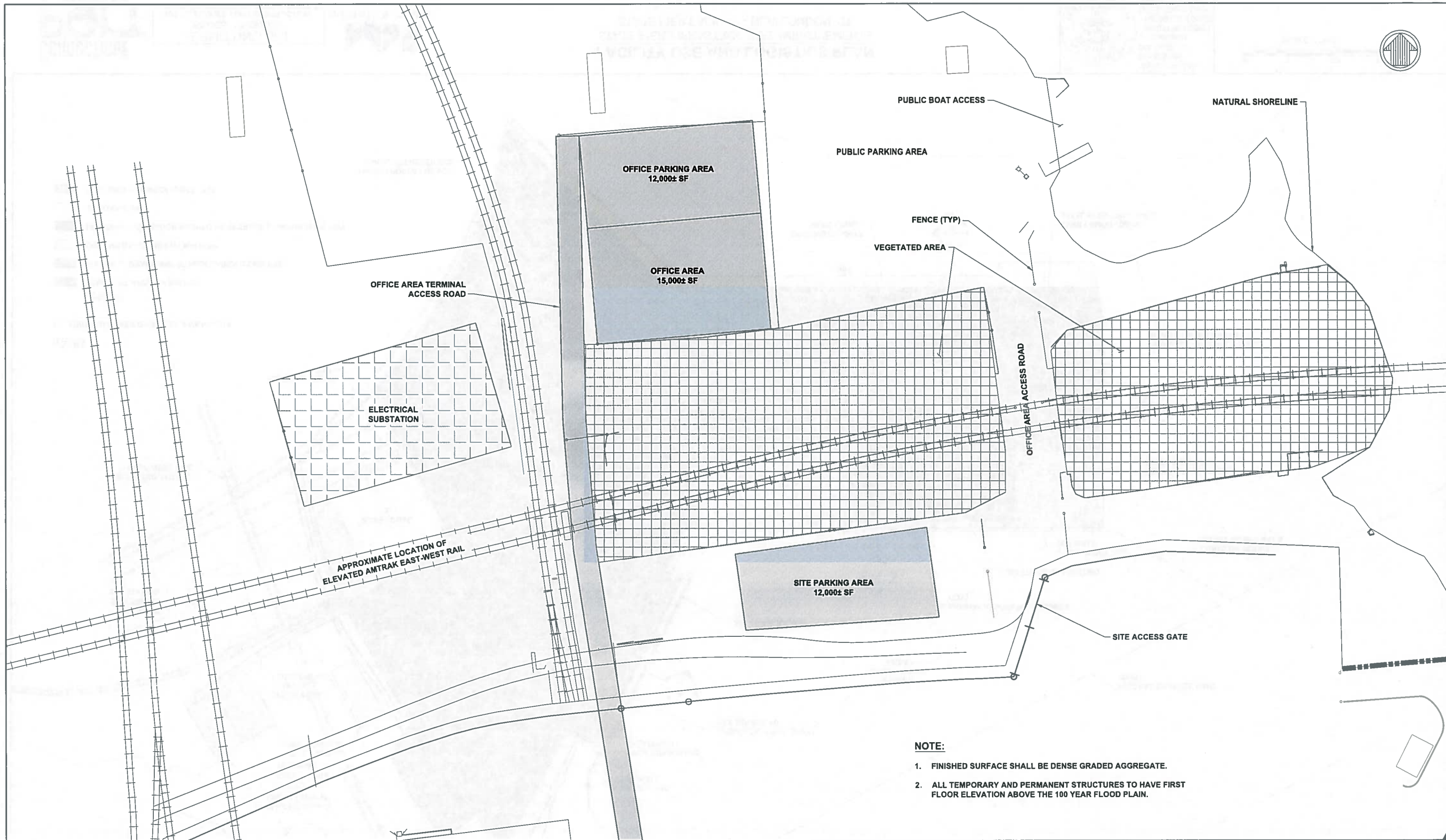

- NOTE:**
1. FINISHED SURFACE SHALL BE DENSE GRADED AGGREGATE.
 2. ALL TEMPORARY AND PERMANENT STRUCTURES TO HAVE FIRST FLOOR ELEVATION ABOVE THE 100 YEAR FLOOD PLAIN.



PERMITTING SET
ISSUED: 10/23/2020
NOT TO BE USED FOR CONSTRUCTION



OFFICE AND PARKING PLAN
STATE PIER INFRASTRUCTURE IMPROVEMENTS
STATE PIER FACILITY - NEW LONDON, CT



Digitally signed by
Eric D Smith
DN: c=US,
o=Unaffiliated,
ou=A01410C000001
71CC9B22C1000095
D6, cn=Eric D Smith
Date: 2020.10.27
10:49:47 -04'00'



DWG INFO: C:\BOS\Projects\116630 Detail Design State Pier\1000 CADD, Active, P\moffatt\10630-10.dwg, June 19, 2020 - 10:31 AM, MIMRANDA, (C) MOFFATT AND NICHOL

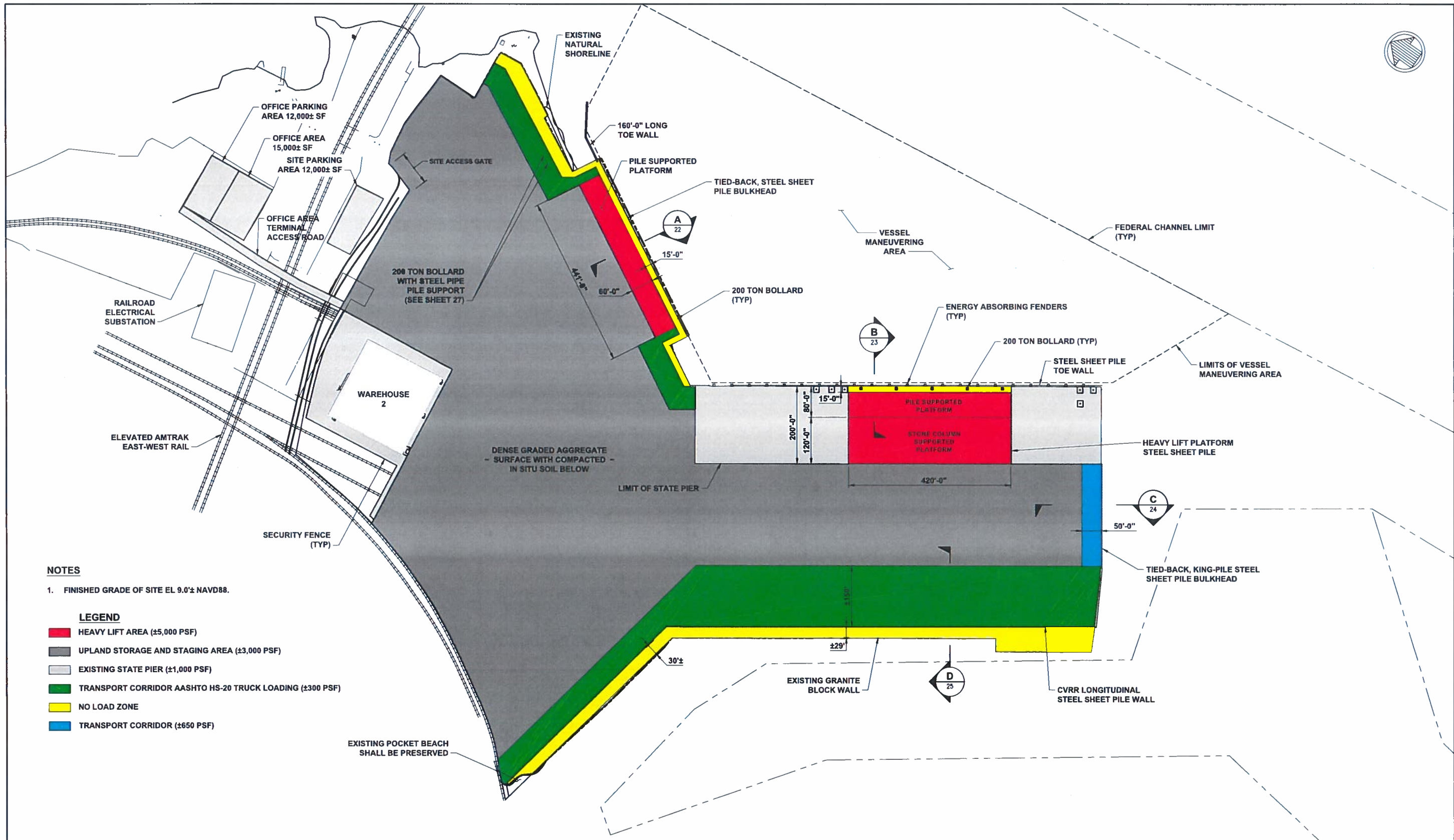

NOTES

1. FINISHED GRADE OF SITE EL 9.0'± NAVD88.

LEGEND

- HEAVY LIFT AREA (±5,000 PSF)
- UPLAND STORAGE AND STAGING AREA (±3,000 PSF)
- EXISTING STATE PIER (±1,000 PSF)
- TRANSPORT CORRIDOR AASHTO HS-20 TRUCK LOADING (±300 PSF)
- NO LOAD ZONE
- TRANSPORT CORRIDOR (±650 PSF)



PERMITTING SET
ISSUED: 10/23/2020
NOT TO BE USED FOR CONSTRUCTION



FACILITY USE AND LOGISTICS PLAN
STATE PIER INFRASTRUCTURE IMPROVEMENTS
STATE PIER FACILITY - NEW LONDON, CT



Digitally signed by
Eric D Smith
DN: c=US,
o=Unaffiliated,
ou=A01410C000001
71CC9B22C1000095
D6, cn=Eric D Smith
Date: 2020.10.27
10:52:50 -04'00'

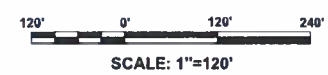

DWG INFO: O:\BOS\Projects\10630 Detail Design State pier\10630-19.dwg, May 1, 2021 - 5:21 PM, MAIRANDA, (C) MOFFATT AND NICHOL

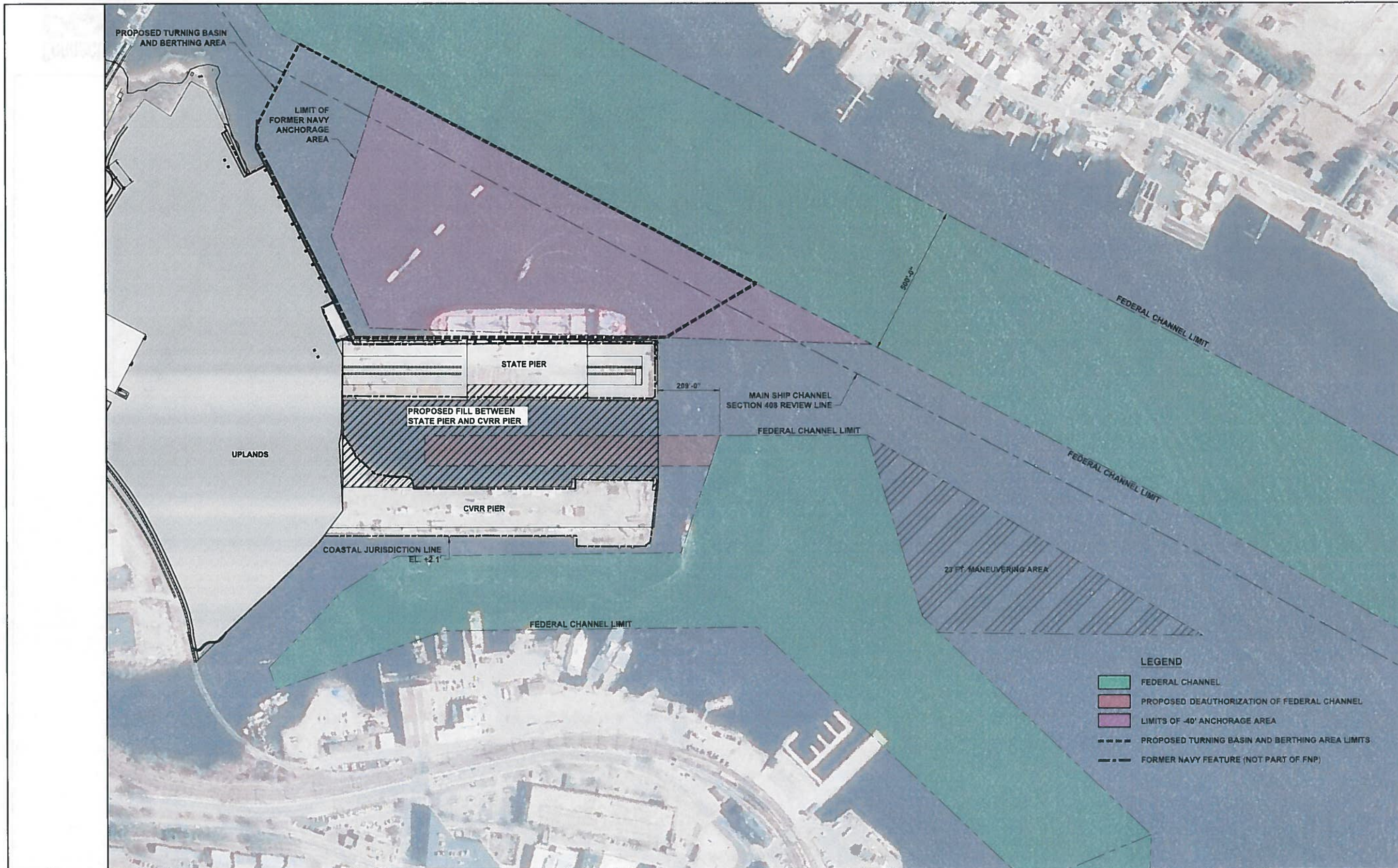

- LEGEND**
- FEDERAL CHANNEL
 - PROPOSED DEAUTHORIZATION OF FEDERAL CHANNEL
 - LIMITS OF -40' ANCHORAGE AREA
 - PROPOSED TURNING BASIN AND BERTHING AREA LIMITS
 - FORMER NAVY FEATURE (NOT PART OF FNP)



PERMITTING SET
ISSUED: 10/23/2020
NOT TO BE USED FOR CONSTRUCTION



FEDERAL CHANNEL MAP PLAN
STATE PIER INFRASTRUCTURE IMPROVEMENTS
STATE PIER FACILITY - NEW LONDON, CT

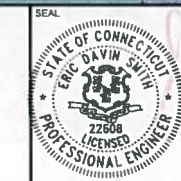

Digitally signed by
Eric D Smith
DN: c=US,
o=Unaffiliated,
ou=A01410C000001
71CC9B22C1000095
D6, cn=Eric D Smith
Date: 2020.10.27
10:56:23 -04'00'

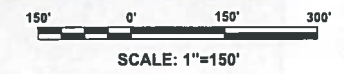

DWG INFO: Q:\BOS\Projects\10630_Design\State pier\500 CAD\DWG\PermitSet\10630-20.dwg; May 1, 2020 - 4:10 PM, MANRANGA, (C) MOFFATT AND NICHOL

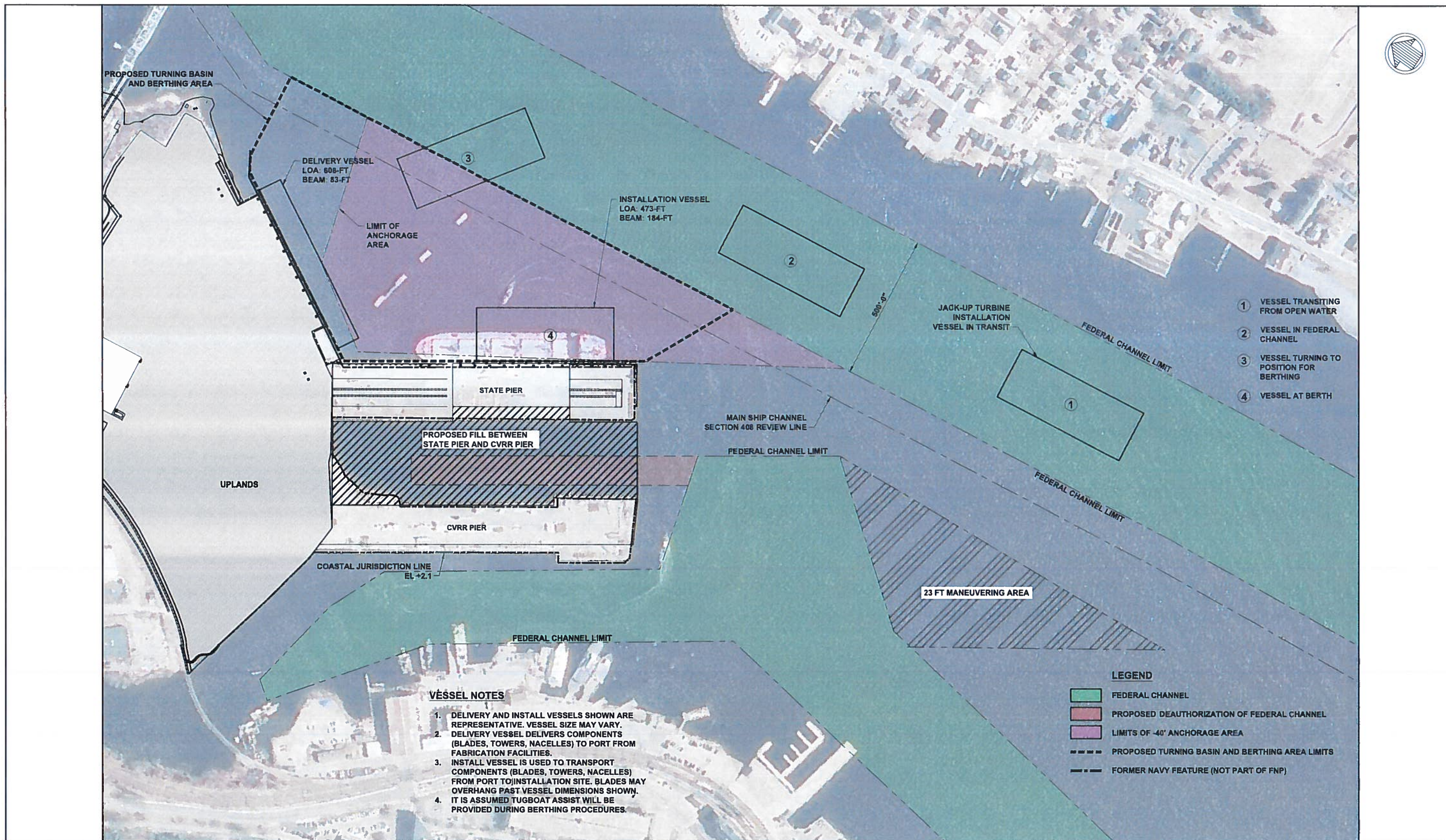

- ① VESSEL TRANSITING FROM OPEN WATER
- ② VESSEL IN FEDERAL CHANNEL
- ③ VESSEL TURNING TO POSITION FOR BERTHING
- ④ VESSEL AT BERTH

- VESSEL NOTES**
1. DELIVERY AND INSTALL VESSELS SHOWN ARE REPRESENTATIVE. VESSEL SIZE MAY VARY.
 2. DELIVERY VESSEL DELIVERS COMPONENTS (BLADES, TOWERS, NACELLES) TO PORT FROM FABRICATION FACILITIES.
 3. INSTALL VESSEL IS USED TO TRANSPORT COMPONENTS (BLADES, TOWERS, NACELLES) FROM PORT TO INSTALLATION SITE. BLADES MAY OVERHANG PAST VESSEL DIMENSIONS SHOWN.
 4. IT IS ASSUMED TUGBOAT ASSIST WILL BE PROVIDED DURING BERTHING PROCEDURES.

- LEGEND**
- FEDERAL CHANNEL
 - PROPOSED DEAUTHORIZATION OF FEDERAL CHANNEL
 - LIMITS OF 40' ANCHORAGE AREA
 - PROPOSED TURNING BASIN AND BERTHING AREA LIMITS
 - FORMER NAVY FEATURE (NOT PART OF FNP)



PERMITTING SET
ISSUED: 10/23/2020
NOT TO BE USED FOR CONSTRUCTION



INSTALL VESSEL NAVIGATION PLAN (INBOUND)
STATE PIER INFRASTRUCTURE IMPROVEMENTS
STATE PIER FACILITY - NEW LONDON, CT

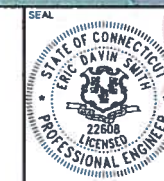

Digitally signed by
Eric D Smith
DN: c=US,
o=Unaffiliated,
ou=A01410C000001
71CC9B22C1000095
D6, cn=Eric D Smith
Date: 2020.10.27
10:59:17 -04'00'

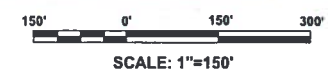

DWG INFO: C:\BOS\Projects\106301\Detail Design\State pier\500 CAD\01_Actual_PermitSet\1063021.dwg, May 1, 2020 - 4:09 PM, MARRANDA, (C) MOFFATT AND NICHOL

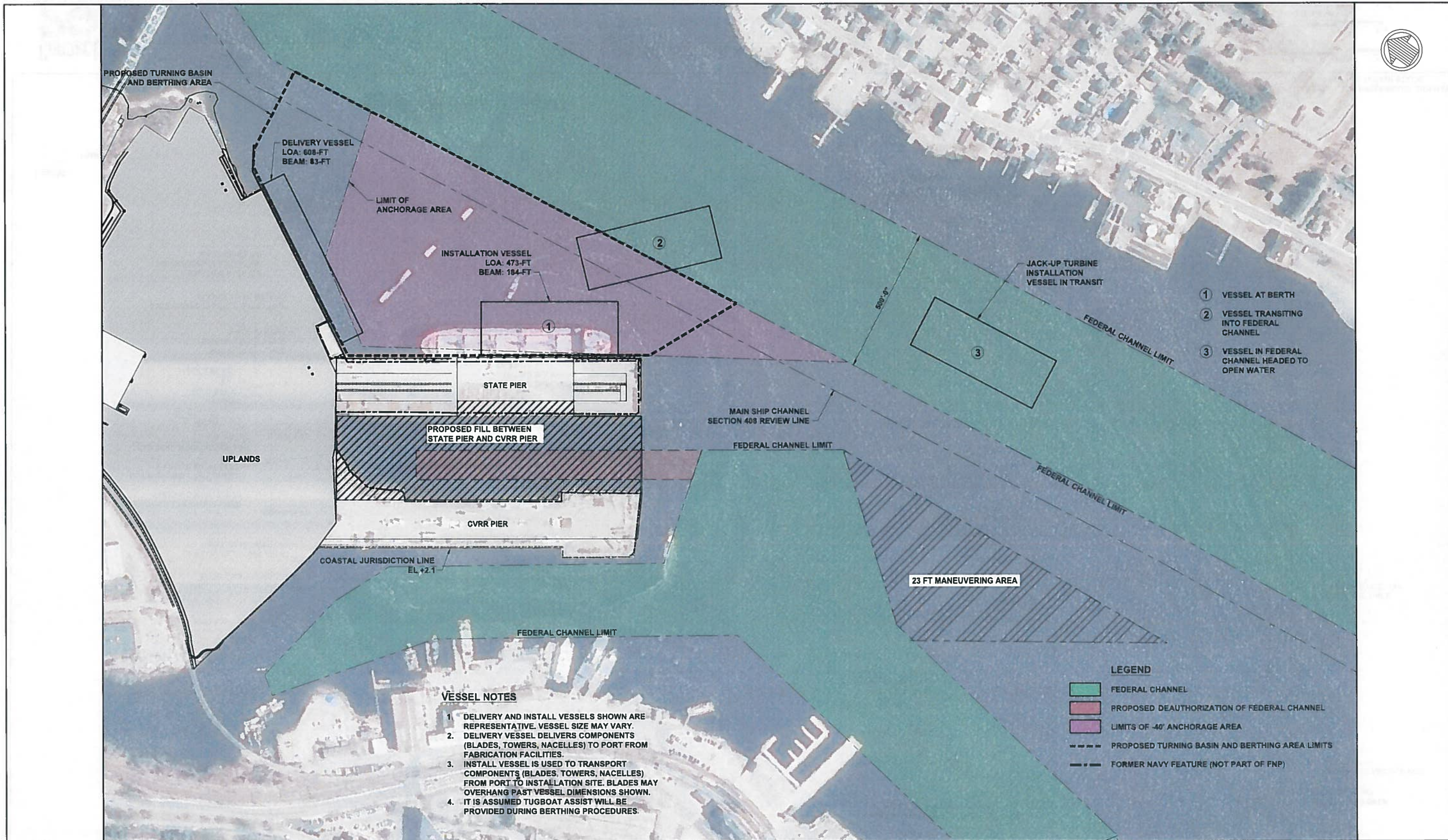

- ① VESSEL AT BERTH
- ② VESSEL TRANSITING INTO FEDERAL CHANNEL
- ③ VESSEL IN FEDERAL CHANNEL HEADED TO OPEN WATER

- VESSEL NOTES**
1. DELIVERY AND INSTALL VESSELS SHOWN ARE REPRESENTATIVE. VESSEL SIZE MAY VARY.
 2. DELIVERY VESSEL DELIVERS COMPONENTS (BLADES, TOWERS, NACELLES) TO PORT FROM FABRICATION FACILITIES.
 3. INSTALL VESSEL IS USED TO TRANSPORT COMPONENTS (BLADES, TOWERS, NACELLES) FROM PORT TO INSTALLATION SITE. BLADES MAY OVERHANG PAST VESSEL DIMENSIONS SHOWN.
 4. IT IS ASSUMED TUGBOAT ASSIST WILL BE PROVIDED DURING BERTHING PROCEDURES.

- LEGEND**
- FEDERAL CHANNEL
 - PROPOSED DEAUTHORIZATION OF FEDERAL CHANNEL
 - LIMITS OF -40' ANCHORAGE AREA
 - PROPOSED TURNING BASIN AND BERTHING AREA LIMITS
 - FORMER NAVY FEATURE (NOT PART OF FNP)



PERMITTING SET
ISSUED: 10/23/2020
NOT TO BE USED FOR CONSTRUCTION



INSTALL VESSEL NAVIGATION PLAN (OUTBOUND)
STATE PIER INFRASTRUCTURE IMPROVEMENTS
STATE PIER FACILITY - NEW LONDON, CT



Digitally signed by Eric D Smith
DN: c=US, o=Unaffiliated, ou=A01410C00000171CC9B22C1000095D6, cn=Eric D Smith
Date: 2020.10.27 11:02:38 -04'00'

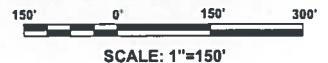

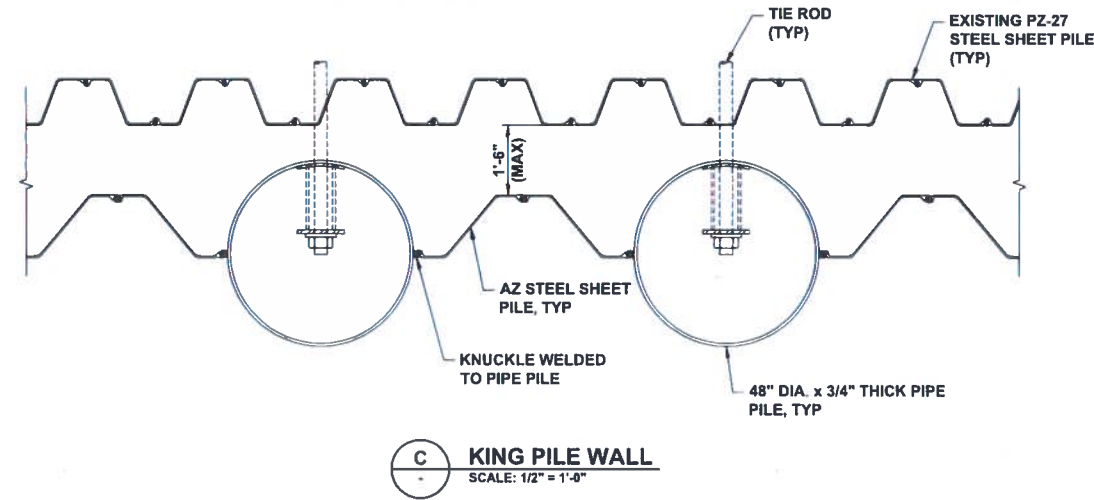

C KING PILE WALL
SCALE: 1/2" = 1'-0"

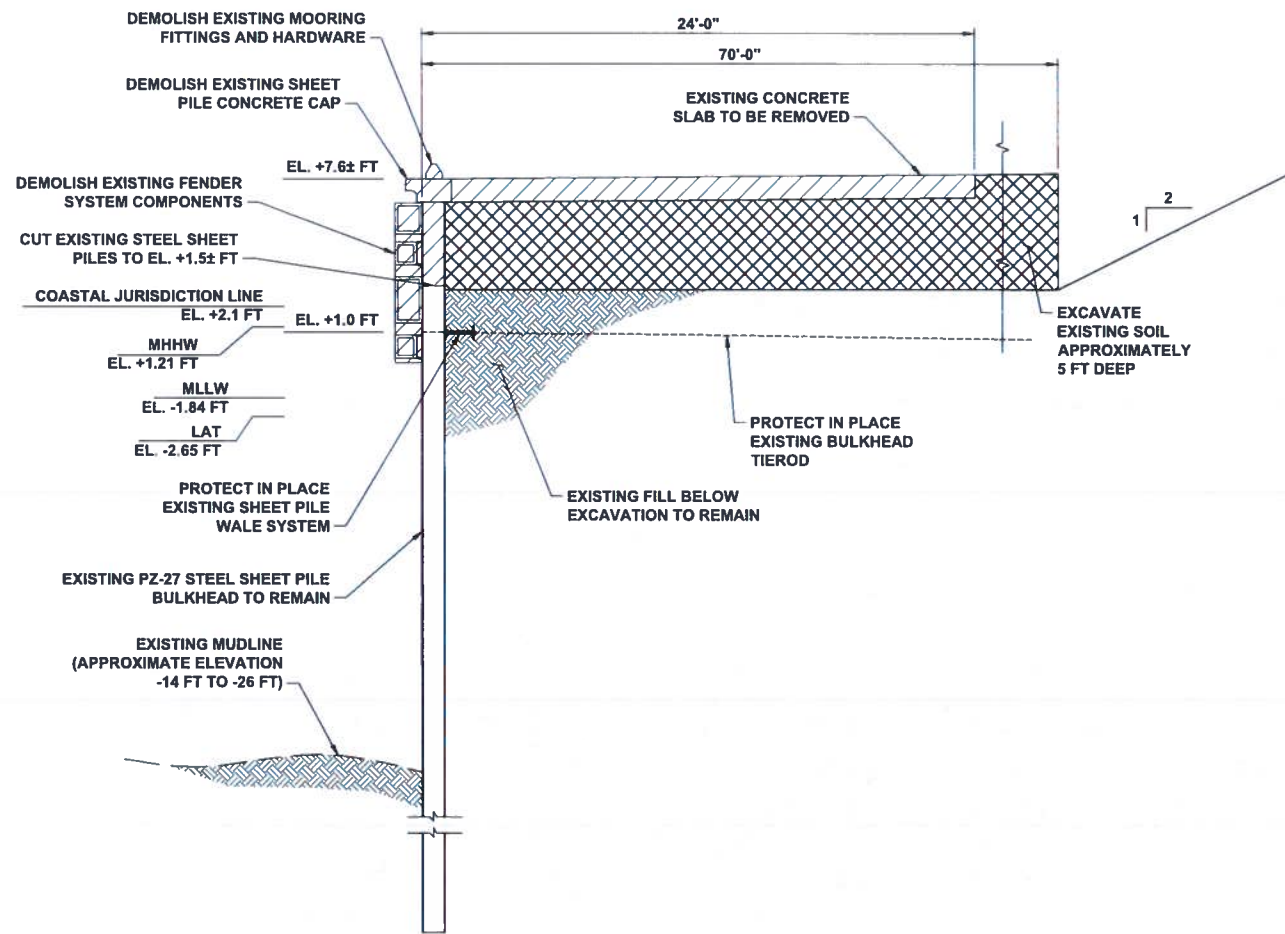

EXISTING - STEEL SHEET PILE BULKHEAD
SCALE: 1/4" = 1'-0"

LEGEND:
[Hatched Box] DEMOLISH

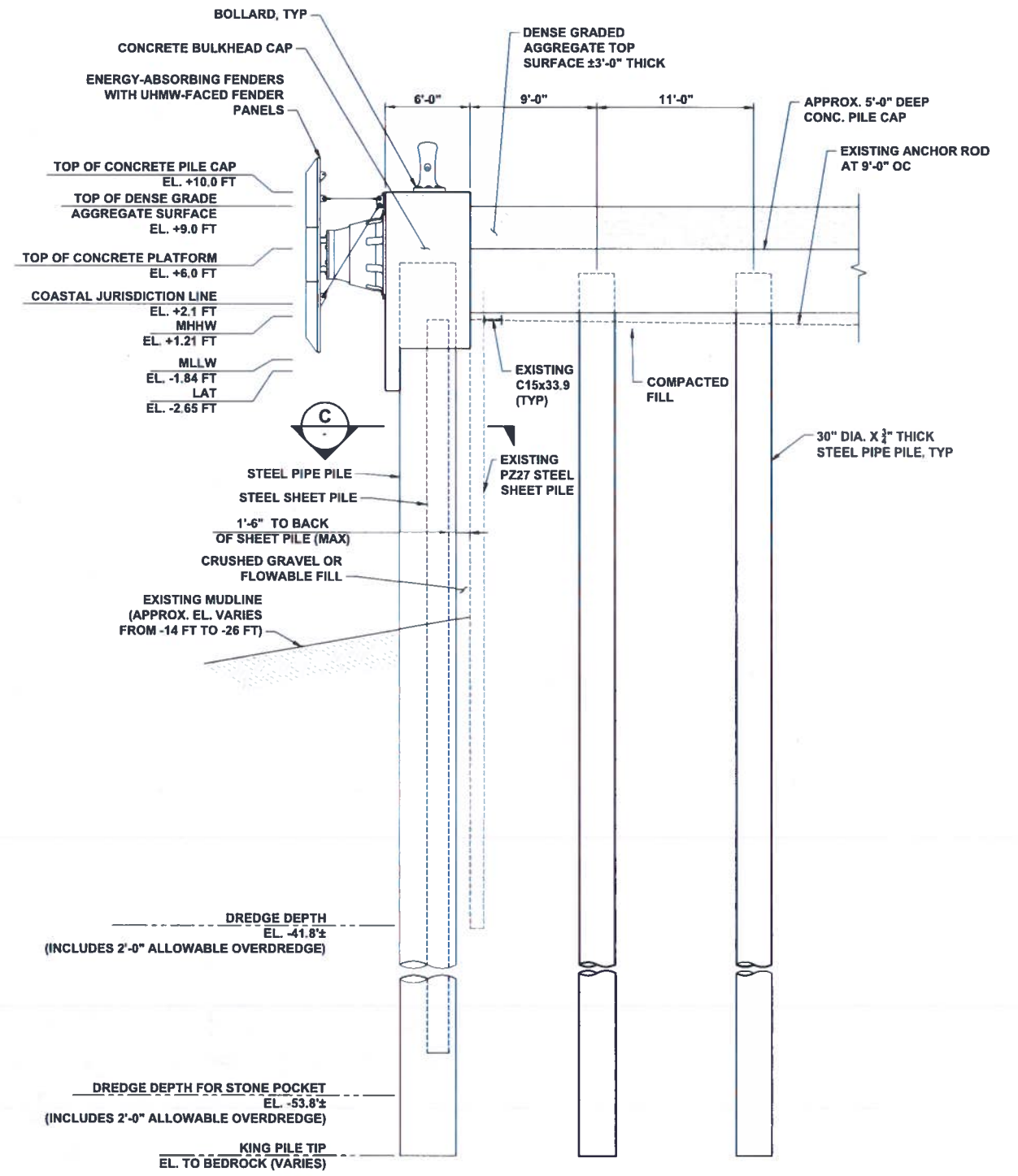

A SECTION
SCALE: 3/16" = 1'-0"

NOTE:
1. MEMBER SIZE IS PRELIMINARY AND MAY CHANGE IN FINAL DESIGN STAGE.

DWG INFO: C:\BOS\Projects\16301 Detail Design\State pier\150 CAD\Drawn\PermitSet\16301-22.dwg; May 5, 2020 - 11:58 AM; CHK:YVINGLESMS; (C) MOFFATT AND NICHOL



PERMITTING SET
ISSUED: 10/23/2020
NOT TO BE USED FOR CONSTRUCTION



NORTHEAST BULKHEAD SECTIONS
STATE PIER INFRASTRUCTURE IMPROVEMENTS
STATE PIER FACILITY - NEW LONDON, CT



Digitally signed by
Matthew Trowbridge
DN: c=US,
o=Unaffiliated,
ou=A01410C0000017
1E55D2F510000A0D
C, cn=Matthew
Trowbridge
Date: 2020.10.28
11:40:11 -07'00'

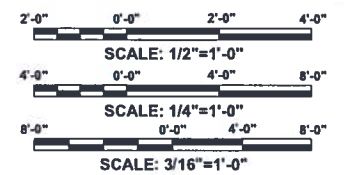

DWG INFO: 0:18:05\Projects\166300_Digital Design State per 1500 CADD_Actual_PermitSet\166300-23.dwg; May 4, 2020 - 6:46 PM; DFRANZESE; (C) MOFFATT AND NICHOL

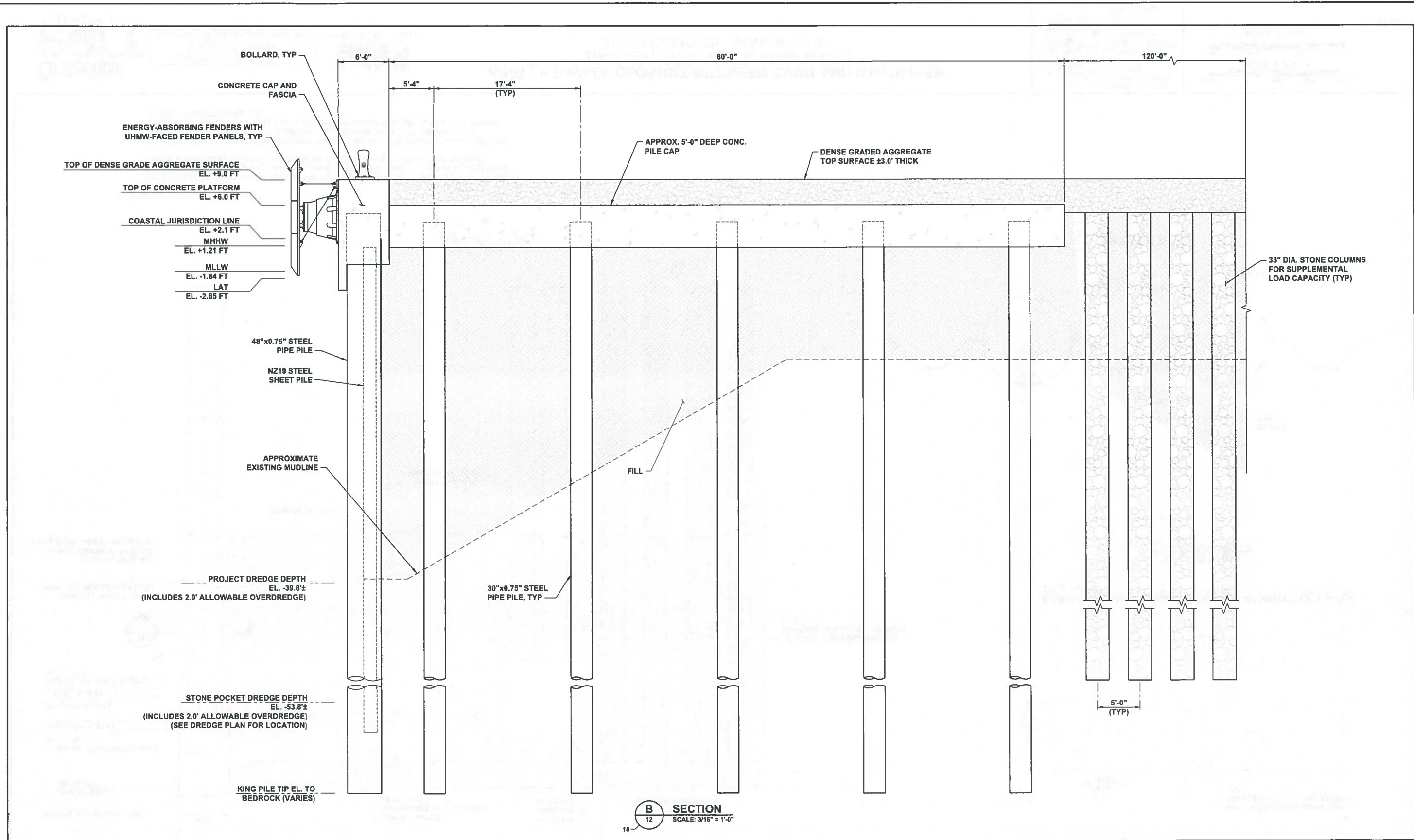

B SECTION
SCALE: 3/16" = 1'-0"



PERMITTING SET
ISSUED: 10/23/2020
NOT TO BE USED FOR CONSTRUCTION



PROPOSED EAST STATE PIER PILE SUPPORTED PLATFORM
STATE PIER INFRASTRUCTURE IMPROVEMENTS
STATE PIER FACILITY - NEW LONDON, CT



Digitally signed by
Matthew Trowbridge
DN: c=US,
o=Unaffiliated,
ou=A01410C0000017
1E55D2F510000AD0
C, cn=Matthew
Trowbridge
Date: 2020.10.28
11:45:09 -0700'

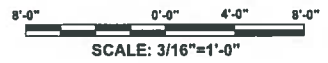

DWG INFO: C:\BOS\Projects\10630_Dread_Design_State_per\100 CAD\DWG_Accell_Perm\10630\10630-24.dwg; October 23, 2020 - 4:00 PM; CAD\YAGLESAS; (C) MOFFATT AND NICHOL

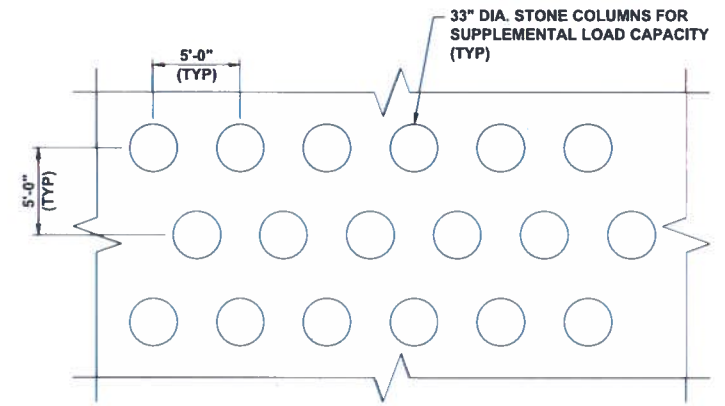
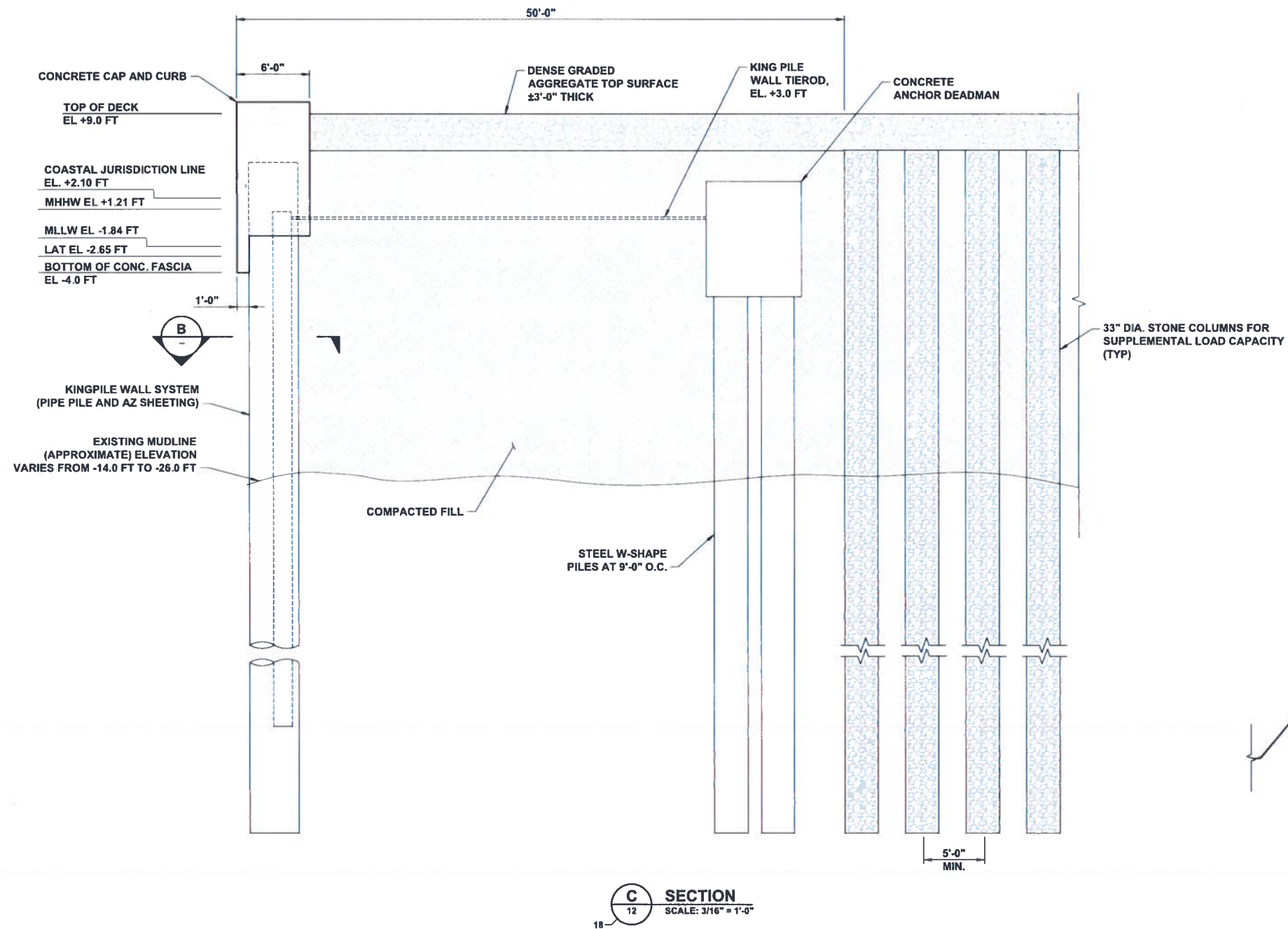

PARTIAL PLAN OF STONE COLUMNS IN HEAVY LIFT AREA
SCALE: 3/16" = 1'-0"

A SECTION
SCALE: 3/16" = 1'-0"

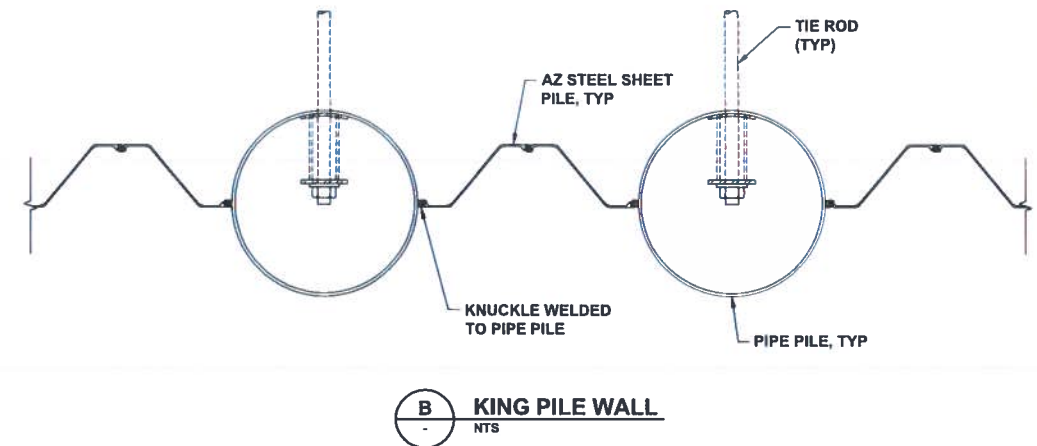

B KING PILE WALL
NTS

C SECTION
SCALE: 3/16" = 1'-0"

NOTES:

1. STONE COLUMNS SHALL COVER APPROXIMATELY 25% OF HEAVY LIFT AREA FOOTPRINT. SPACING AND DIAMETER SHOWN FOR ALL STONE COLUMNS ARE APPROXIMATE AND MAY BE ALTERED BY CONTRACTOR BASED ON AVAILABLE EQUIPMENT AND PREFERRED MEANS AND METHODS.
2. ALTERNATIVE METHODS FOR GROUND IMPROVEMENT WITHIN THE NEW CENTRAL WHARF AREA SUCH AS PREFABRICATED VERTICAL DRAINS (WICK DRAINS) OR VIBRO-COMPACTION OF IMPORTED SOILS MAY BE UTILIZED IN LIEU OF OR IN COMBINATION WITH STONE COLUMNS TO ACHIEVE PROJECT SCHEDULE.



PERMITTING SET
ISSUED: 10/23/2020
NOT TO BE USED FOR CONSTRUCTION



KING PILE WALL CLOSURE BETWEEN CVRR AND STATE PIER
STATE PIER INFRASTRUCTURE IMPROVEMENTS
STATE PIER FACILITY - NEW LONDON, CT



Digitally signed by
Matthew Trowbridge
DN: c=US,
o=Unaffiliated,
ou=A01410C0000017
1E5D2F510000A0D
C, cn=Matthew
Trowbridge
Date: 2020.10.28
11:47:21 -0700

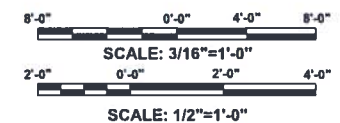

DWG INFO: C:\BOS\Projects\10630_Digital Design\State Pier\10630-25.dwg; October 15, 2020 - 2:37 PM; C:\NOY\AGLES\AS (C) MOFFATT AND NICHOL

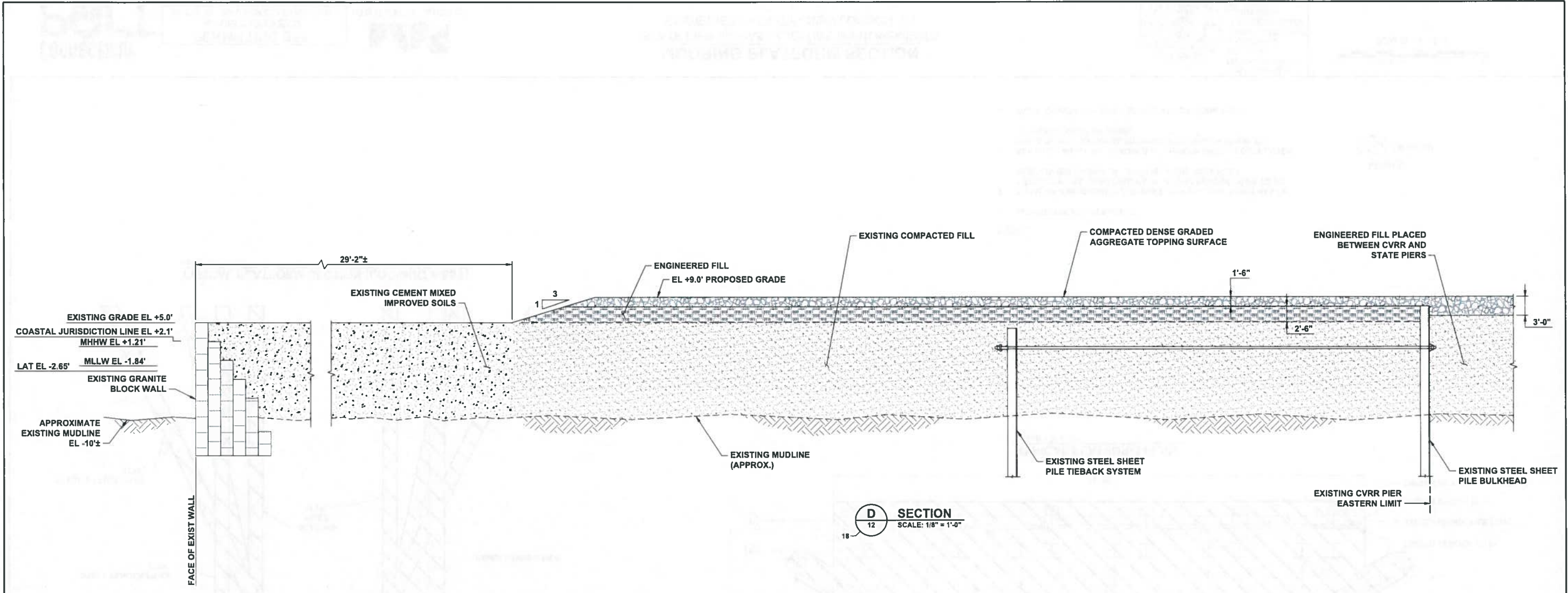

D SECTION
SCALE: 1/8" = 1'-0"

NOTES:

- EASTERN END OF INSTALLED FILL WILL BE RETAINED BY CENTRAL BERM OF EXISTING STATE PIER.
- CONSTRUCTION OF GRANITE BLOCK WALL BELOW MUDLINE IS UNKNOWN. APPROXIMATE SECTION IS SHOWN.
- SHEET SIZE IS APPROXIMATE AND MAY CHANGE IN DETAILED DESIGN.



PERMITTING SET
ISSUED: 10/23/2020
NOT TO BE USED FOR CONSTRUCTION



CVRR BULKHEAD SECTIONS
STATE PIER INFRASTRUCTURE IMPROVEMENTS
STATE PIER FACILITY - NEW LONDON, CT



Digitally signed by
Matthew Trowbridge
DN: c=US,
o=Unaffiliated,
ou=A01410C0000017
1E55D2F510000AD0
C, cn=Matthew
Trowbridge
Date: 2020.10.28
11:49:36 -07'00'

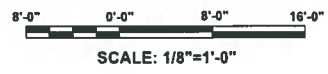

DWG INFO: C:\BOS\Projects\10630_Dread Design State pier\1000 CADD Acadt PermsSet\10630-26.dwg; May 4, 2020, 5:39 PM; DFRANZESE, (C) MOFFATT AND NICHOL

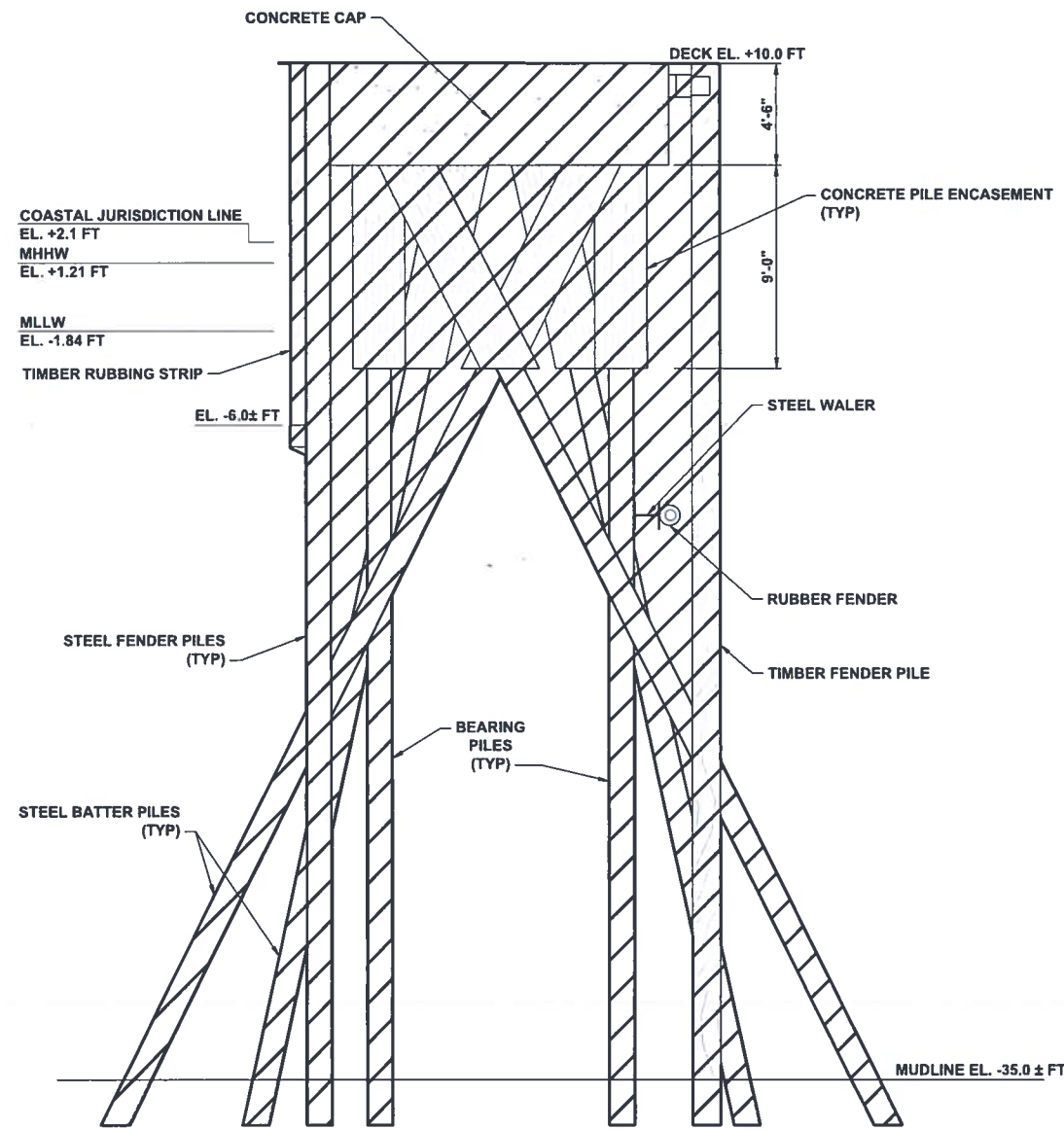

TYPICAL PLATFORM SECTION (LOOKING WEST)
SCALE: 1/4" = 1'-0"

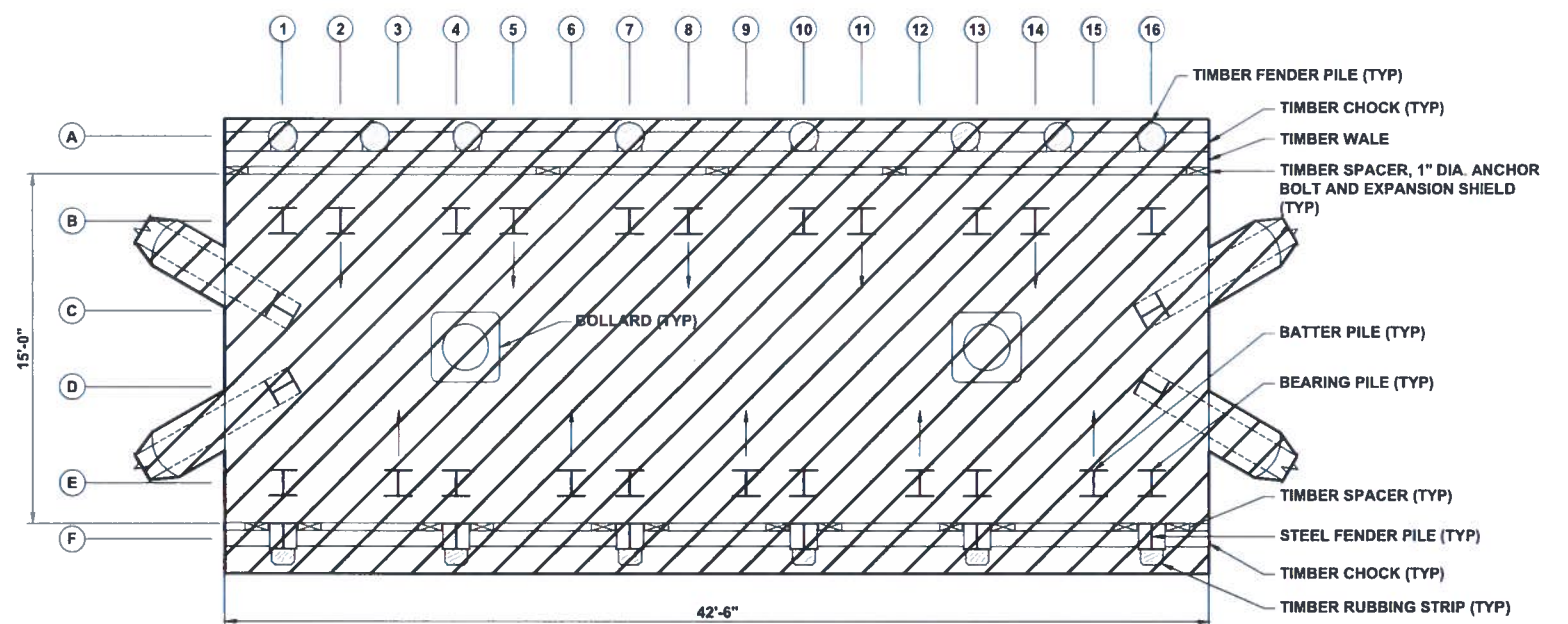

TYPICAL PLATFORM PLAN
SCALE: 1/4" = 1'-0"

NOTES:

1. ELEVATIONS ARE IN NAVD88.
2. TOTAL OF 4 MOORING PLATFORMS - TYPICAL PLATFORM HAS 12 SUPPORT PILES, 14 BATTER PILES, AND 14 FENDER PILES TO BE DEMOLISHED. CATWALK CONTAINS 8 SUPPORT PILES.
3. ALL PILES SHALL BE REMOVED IN THEIR ENTIRETY. CONTRACTOR SHALL SUBMIT REMOVAL METHODS FOR REVIEW PRIOR TO COMMENCEMENT OF WORK.
4. WORK COVERED UNDER CERTIFICATE OF PERMISSION.

LEGEND



PERMITTING SET
ISSUED: 10/23/2020
NOT TO BE USED FOR CONSTRUCTION



MOORING PLATFORM SECTION
STATE PIER INFRASTRUCTURE IMPROVEMENTS
STATE PIER FACILITY - NEW LONDON, CT



Digitally signed by
Matthew Trowbridge
DN: c=US,
o=Unaffiliated,
ou=A01410C0000017
1E55D2F51000AD0
C, cn=Matthew
Trowbridge
Date: 2020.10.28
11:51:22 -07'00'

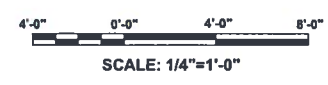

DWG INFO: C:\BOS\Projects\10630 Detail Design State Pier\10630-CADD_Active\PermitSet\10630-27.dwg; May 4, 2020 - 10:13 PM; C:\NOY\ANGLESAS; (C) MOFFATT AND NICHOL

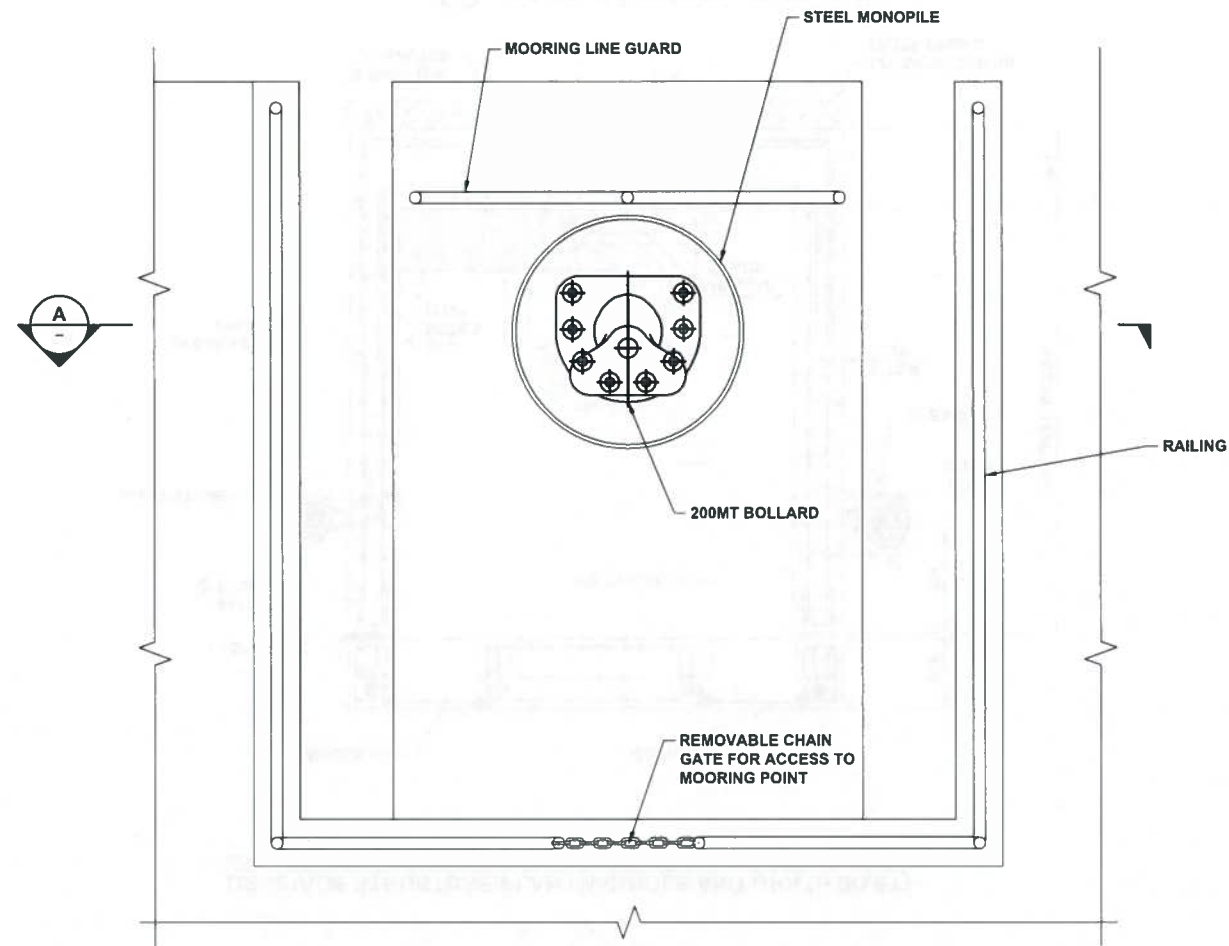

TYPICAL MOORING DOLPHIN PLAN AT STATE PIER
SCALE: 1/2"=1'-0"

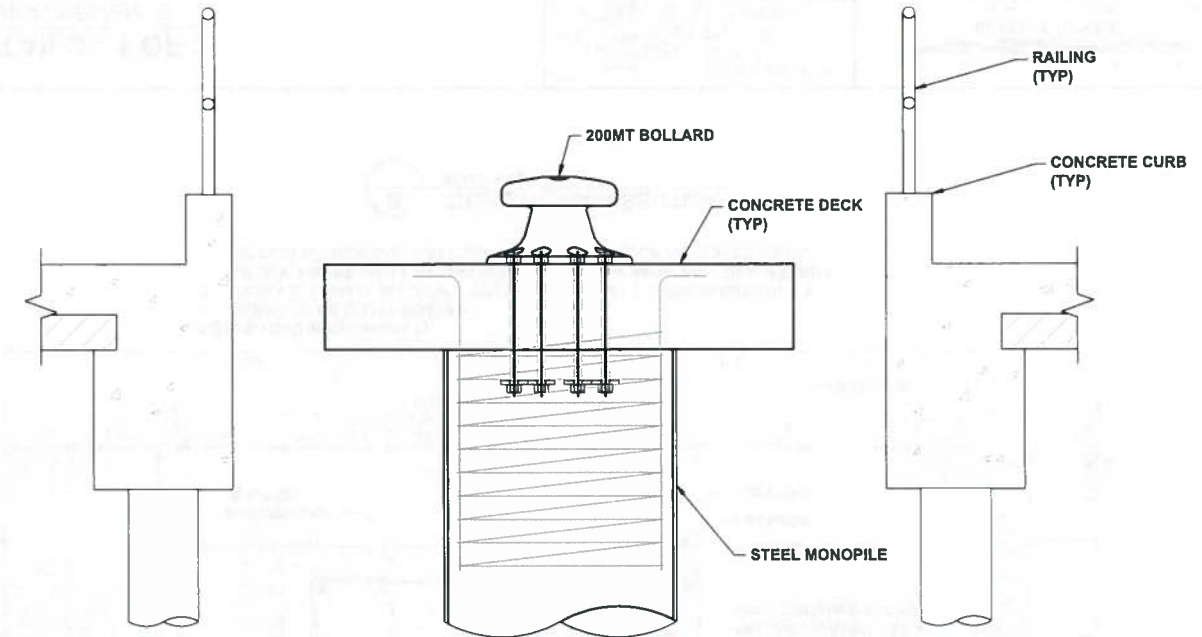

A TYPICAL MOORING DOLPHIN ELEVATION AT STATE PIER
SCALE: 1/2"=1'-0"

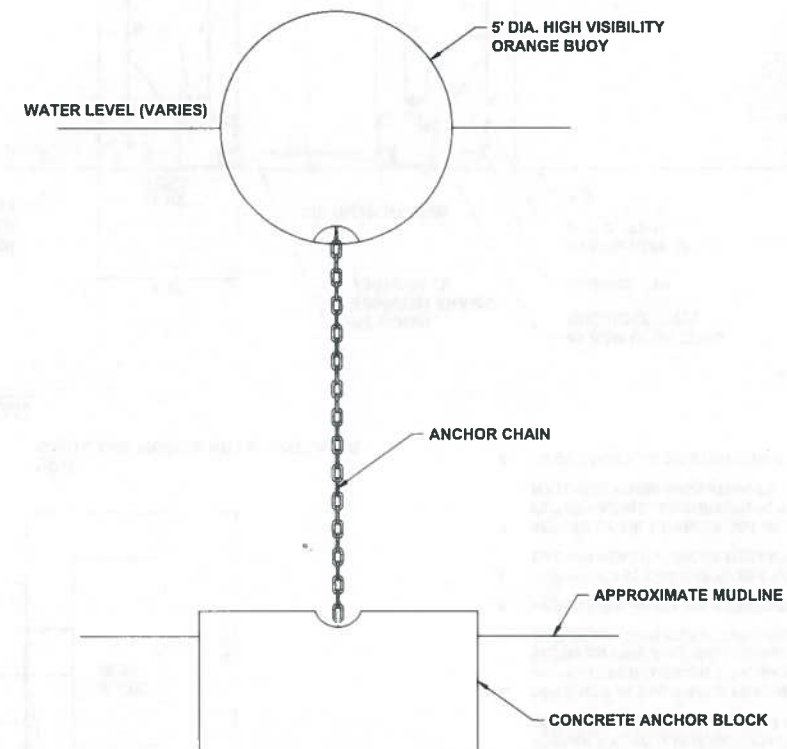

BUOY ANCHORAGE DETAIL
SCALE: 1/2"=1'-0"

BUOY NOTES:

1. LENGTH OF ANCHORAGE CHAIN SHALL ACCOMMODATE FULL TIDE CYCLE.
2. CONCRETE ANCHOR BLOCK SIZING SHALL PROHIBIT MOVEMENT OF BUOY.
3. BUOYS AND ANCHOR BLOCKS SHALL BE REMOVED UPON COMPLETION OF WORK.
4. BUOYS SHALL BE MARKED WITH THE FOLLOWING "STATE PIER WORK ZONE LIMITS".



PERMITTING SET
ISSUED: 10/23/2020
NOT TO BE USED FOR CONSTRUCTION



BUOY ANCHORAGE AND MOORING DOLPHIN DETAILS
STATE PIER INFRASTRUCTURE IMPROVEMENTS
STATE PIER FACILITY - NEW LONDON, CT



Digitally signed by
Matthew Trowbridge
DN: c=US,
o=Unaffiliated,
ou=A01410C00000171
E55D2F510000AD0C,
cn=Matthew
Trowbridge
Date: 2020.10.28
11:52:49 -0700'

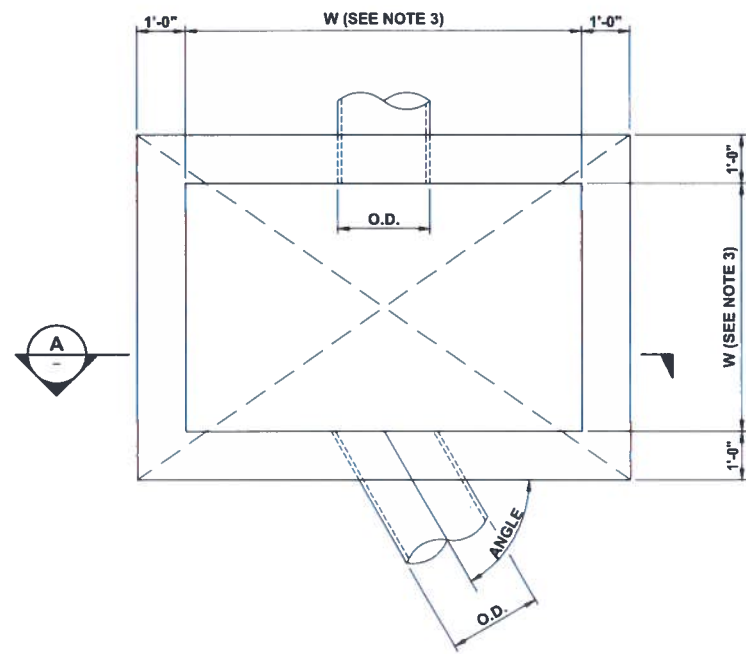

DRAINAGE STRUCTURE PLAN (MANHOLE AND GRATE INLET)

SCALE: 1/2" = 1'-0"

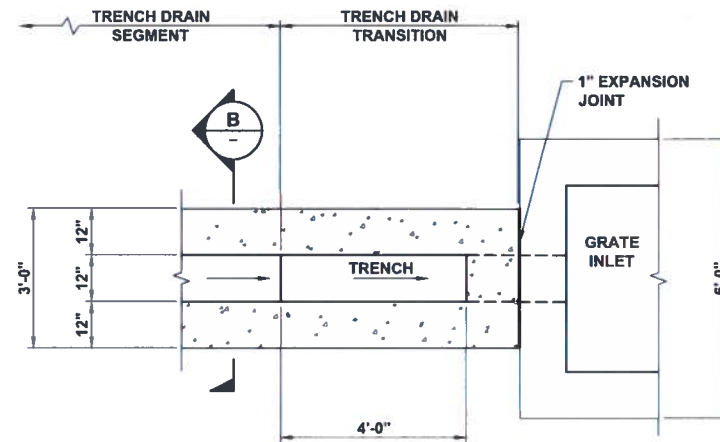

TRENCH DRAIN PLAN

SCALE: 1/2" = 1'-0"

INLET NOTES

1. FRAME AND GRATES SHALL BE AS FOLLOWS (OR APPROVED EQUALS):
QUAD: NEENAH R-4994-HAB (TYPE A GRATE AND TYPE S FRAME)
2. GRATE SHALL BE BOLTED TO THE FRAME.
3. MINIMUM INSIDE WALL DIMENSION "W" SHALL BE DETERMINED BY THE FORMULA $W = (O.D. / \sin \text{ANGLE}) + 2'-6"$, BUT IN NO CASE SHALL THE DIMENSION "W" BE LESS THAN 4 FEET NOR MORE THAN 8 FEET.
4. OPENINGS IN THE WALLS FOR PIPE SHALL BE CAST-IN OR CUT CLEANLY WITHOUT PERCUSSION TO A MAXIMUM DIAMETER OF O.D. ±3". THE SPACE BETWEEN PIPE AND WALL SHALL THEN BE FILLED WITH NON SHRINK GROUT, OR APPROVED JOINT INSERT ASSEMBLY.
5. PRECASTER SHALL BE RESPONSIBLE FOR DESIGNING LIFTING PROVISIONS.
6. FOR PRECAST CONCRETE SECTIONS, MINIMUM COVER IS 2". FOR CAST-IN-PLACE CONCRETE SECTIONS, MINIMUM COVER IS 3".
7. SECURELY TIE 1 CUBIC FOOT OF NO. 57 STONE IN BAG OF NON-WOVEN FILTER FABRIC. ENSURE POSITIVE CLOSURE AROUND PIPE TO PREVENT MATERIAL FROM MIGRATING OUT OF PIPE.
8. GROUT BOTTOM OF STRUCTURE TO INVERT OF PIPE. DEPTH VARIES.

NOTE:
GRATE AND FRAMES NOT ILLUSTRATED.

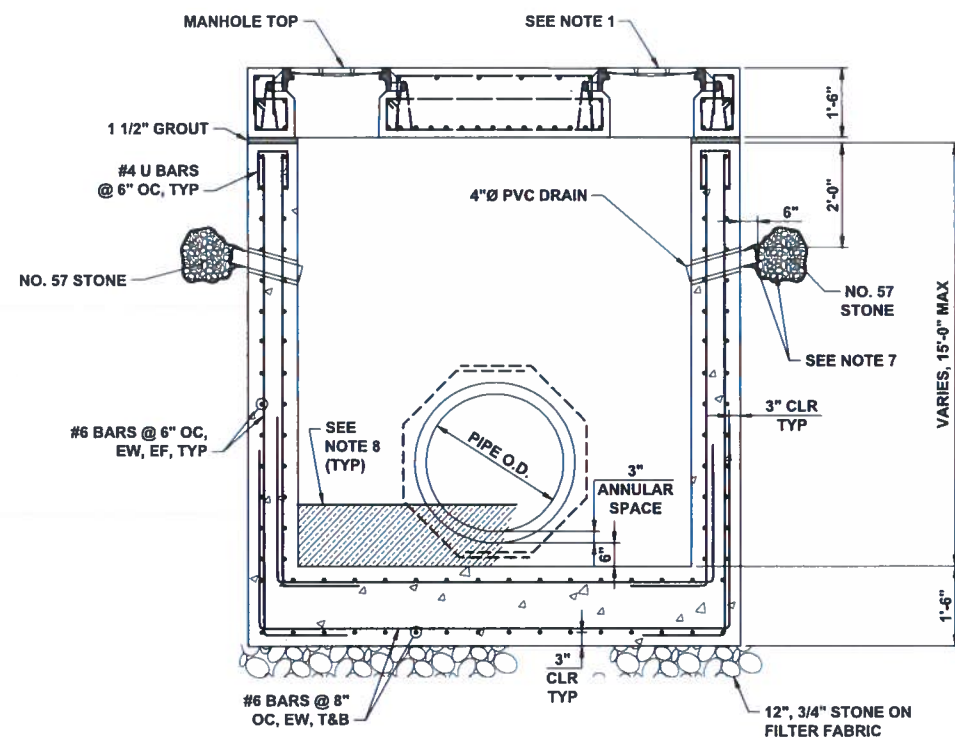

A DRAINAGE STRUCTURE SECTION

SCALE: 1/2" = 1'-0"

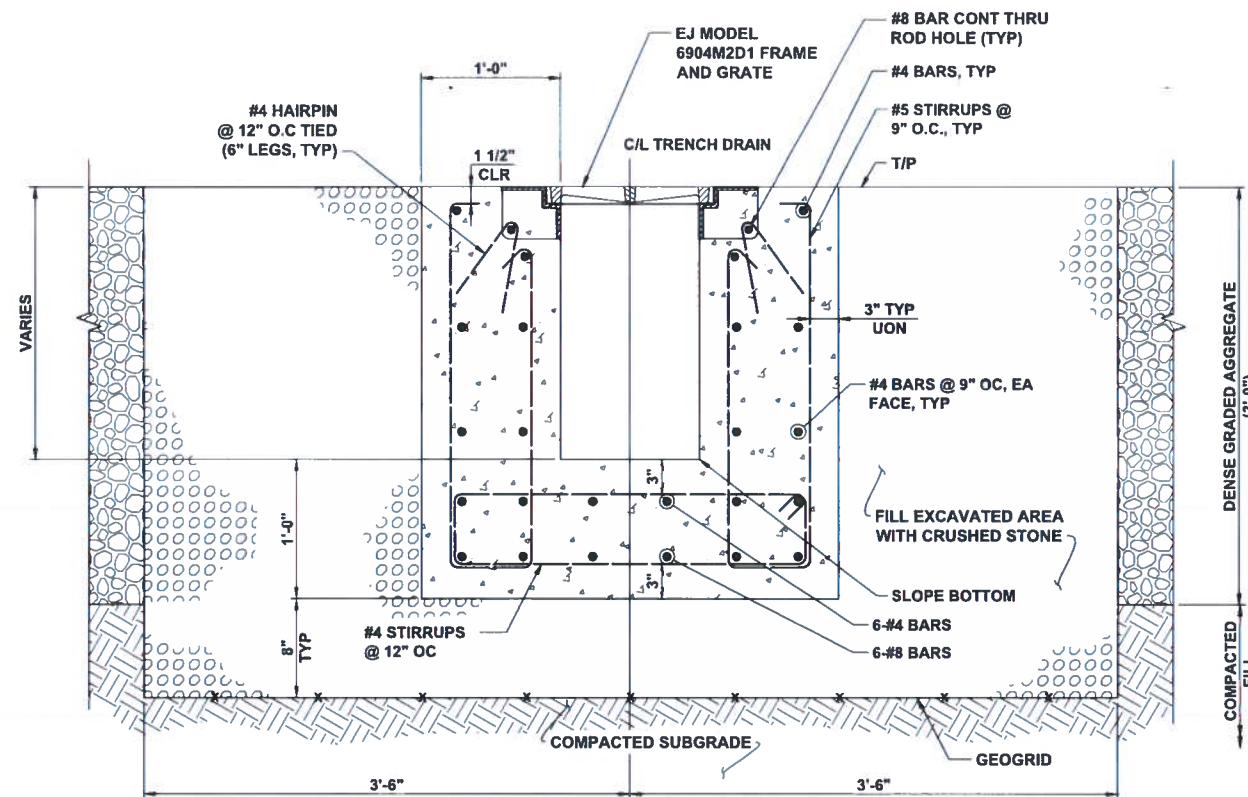

NOTES: (THIS SECTION ONLY)

1. REBAR TO BE EPOXY COATED.
2. CONCRETE SHALL INCLUDE SYNTHETIC FIBERS AT A DOSAGE RATE OF 1.5 LBS/CY. FIBERS SHALL BE MASTERFIBER M 100 BY BASF, PSI FIBERSTRAND F BY EUCLID CHEMICAL, SIKAFIBER PPM 150 BY SIKA, OR APPROVED EQUAL.

B TRENCH DRAIN SECTION

SCALE: 1 1/2" = 1'-0"

DWG INFO: C:\BOS\Projects\16630_Digital Design State pier\500 CADD, Actval, PermitSet\10630-30.dwg, May 4, 2020 - 7:31 PM, CHOVANGLESNAS, (C) MOFFATT AND NICHOL

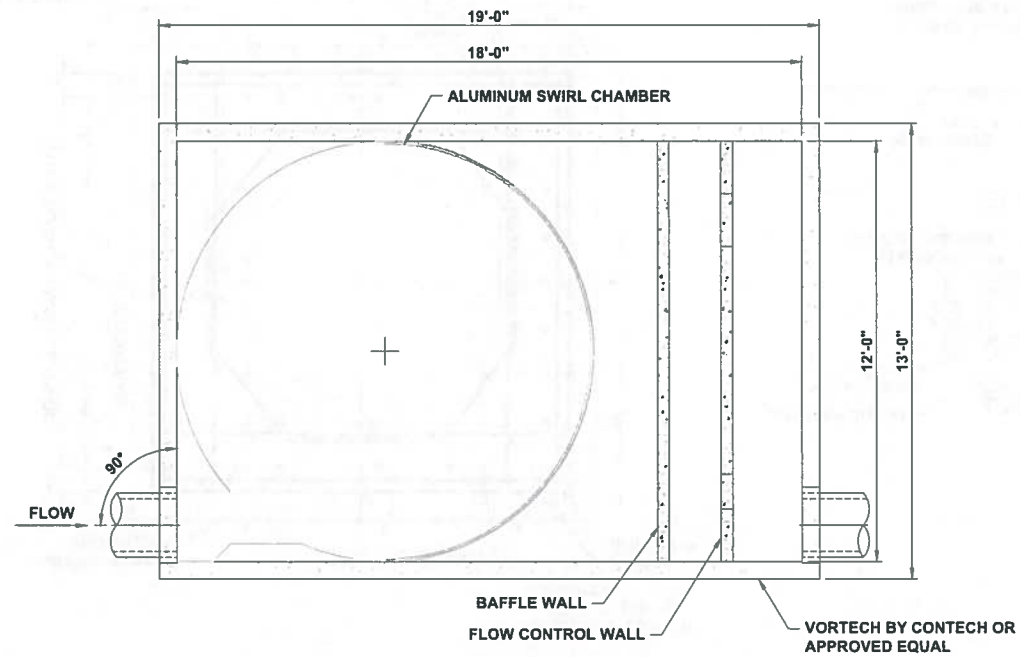

WATER TREATMENT STRUCTURE PLAN
N.T.S.

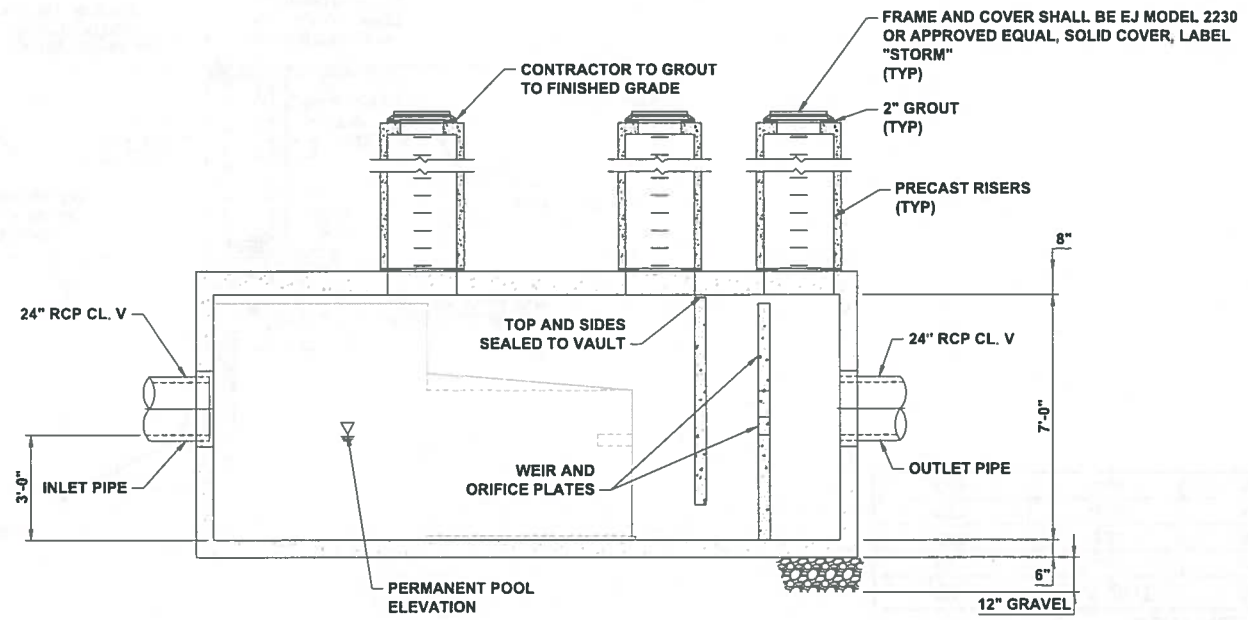

WATER TREATMENT STRUCTURE ELEVATION
N.T.S.

NOTES:

1. STRUCTURES SHOWN ARE REPRESENTATIVE. FINAL SIZING WILL BE PROVIDED BY MANUFACTURER DURING DETAILED DESIGN.
2. SECTIONS ARE NOT TO SCALE.



PERMITTING SET
ISSUED: 10/23/2020
NOT TO BE USED FOR CONSTRUCTION



DRAINAGE STRUCTURE DETAILS - 2 OF 2
STATE PIER INFRASTRUCTURE IMPROVEMENTS
STATE PIER FACILITY - NEW LONDON, CT



Digitally signed by
Eric D Smith
DN: c=US,
o=Unaffiliated,
ou=A01410C000001
71CC9B22C1000095
D6, cn=Eric D Smith
Date: 2020.10.27
11:10:27 -04'00'

DWG INFO: C:\BOS\Projects\10630-31.dwg; May 4, 2020, 1:31 PM; DFRANZESE, (C) MOFFATT AND NICHOL

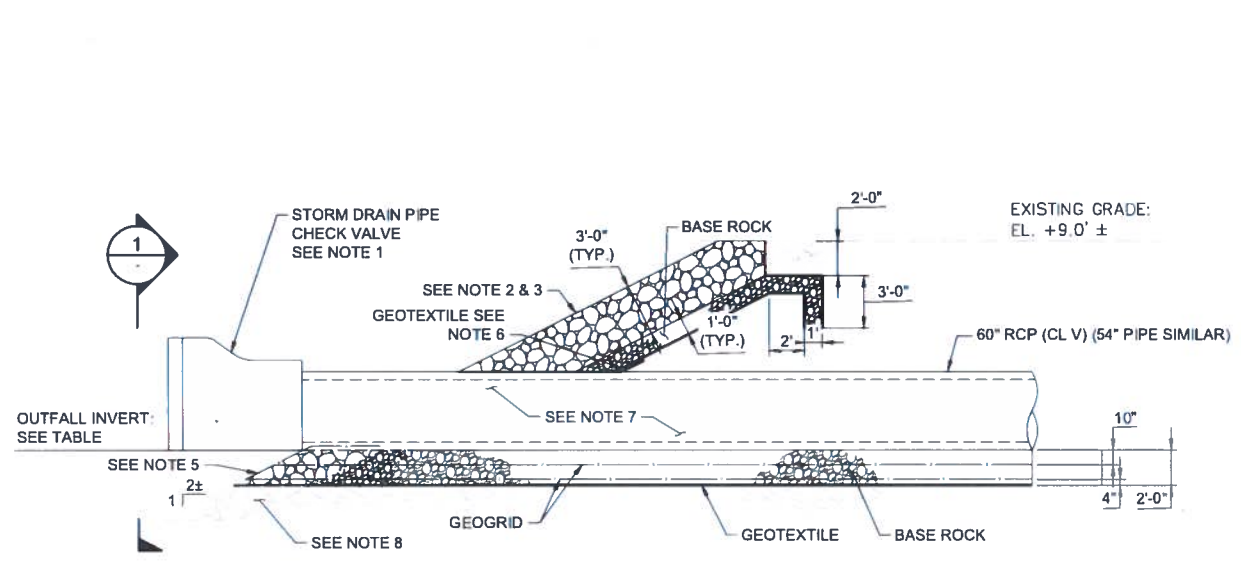

A OUTFALL THROUGH SLOPE (TYPE 1)
SCALE: 3/16" = 1'-0"

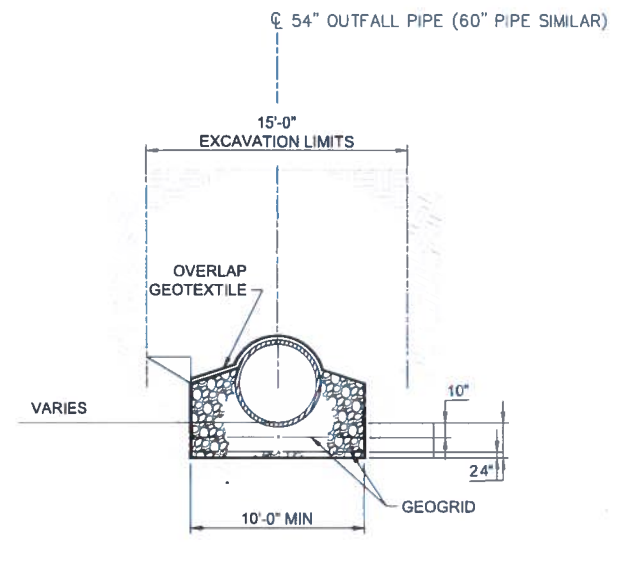

1 SECTION
SCALE: 3/16" = 1'-0"

- NOTES**
1. STORM DRAIN PIPE CHECK VALVE TO BE RED VALVE TIDEFLEX SERIES TF-1 OR APPROVED EQUAL.
 2. SALVAGE EXISTING RIPRAP FOR REUSE.
 3. INSTALL ADDITIONAL RIPRAP (CT DEEP RIPRAP RR DETAIL) AS REQUIRED TO FORM DENSE ARMOR LAYER.
 4. ALL RIPRAP SHALL BE CAREFULLY PLACED, NOT DUMPED.
 5. WRAP LOWER GEOGRID ACROSS FACE OF BASE ROCK.
 6. OVERLAP GEOTEXTILE AROUND PIPE AND SLOPE GEOTEXTILE.
 7. USE FULL PIPE SEGMENT FOR CHECK VALVE MOUNTING.
 8. ALLOW BASE ROCK TO FILL AROUND VOIDS OF EXISTING RIPRAP.
 9. COASTAL JURISDICTION LINE IS AT EL. +2.1'
 10. MHHW IS AT EL. +1.21'
 11. MLLW IS AT EL. -1.84'

OUTFALL			
OF	INV. OUT	SIZE	TYPE
OF1	-4.20	60" Ø	1
OF2	-2.50	54" Ø	2
OF3	-3.10	60" Ø	1
OF4	-4.30	60" Ø	2

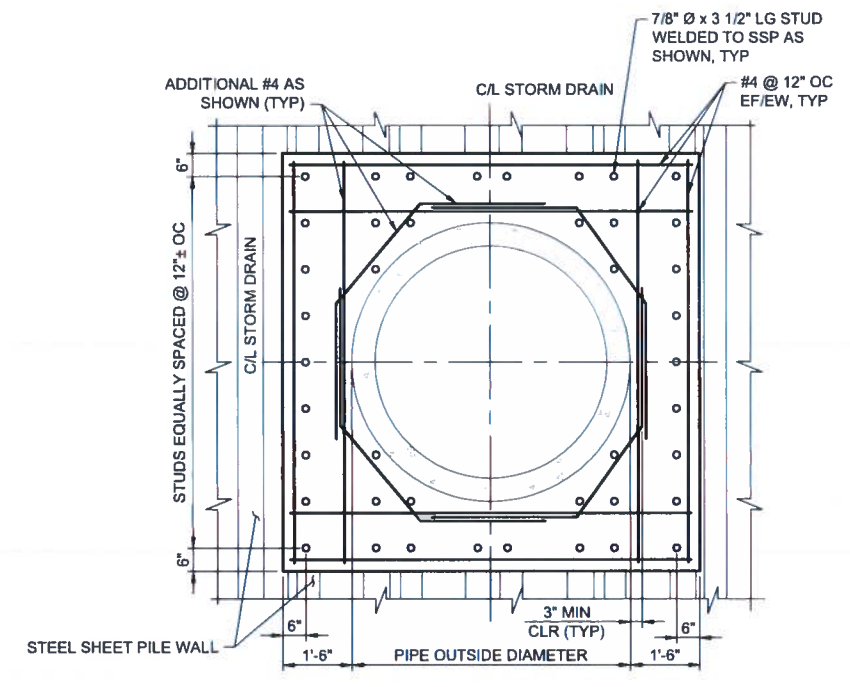

OUTFALL THROUGH STEEL SHEET PILE
SCALE: 1/2" = 1'-0"

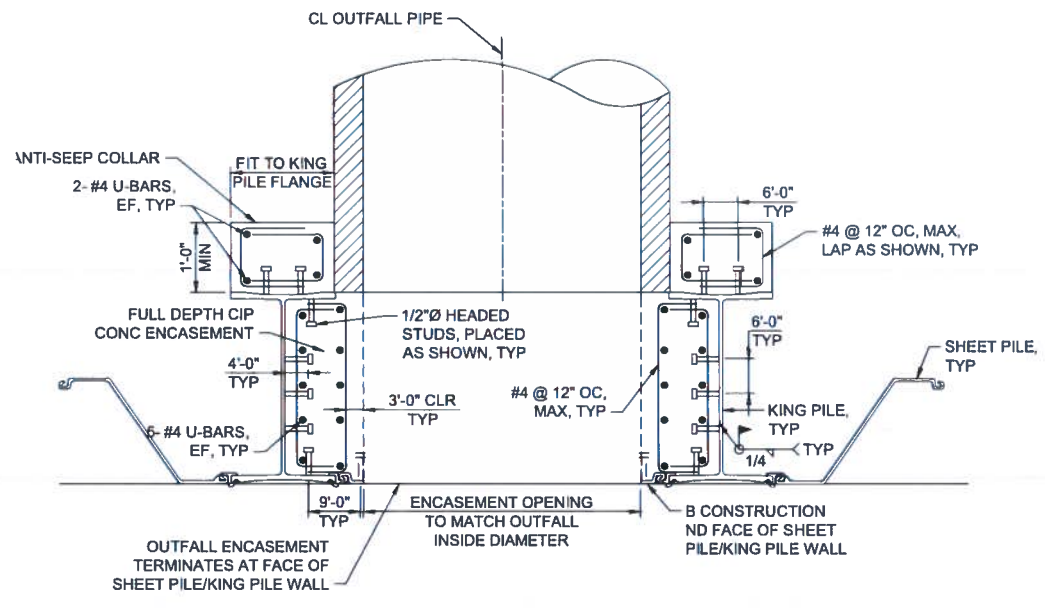

OUTFALL THROUGH STEEL SHEET PILE
SCALE: 1/16" = 1'-0"

B OUTFALL THROUGH STEEL SHEET PILE (TYPE 2)
SCALE: AS NOTED



PERMITTING SET
ISSUED: 10/23/2020
NOT TO BE USED FOR CONSTRUCTION



OUTFALL DETAILS
STATE PIER INFRASTRUCTURE IMPROVEMENTS
STATE PIER FACILITY - NEW LONDON, CT



Digitally signed by
Eric D Smith
DN: c=US,
o=Unaffiliated,
ou=A01410C000001
71CC9B22C1000095
D6, cn=Eric D Smith
Date: 2020.10.27
11:15:27 -04'00'



DWG INFO: Q:\BOS\Projects\10630 Detail Design State pier\500 CAD\01_Acct\PermitSet\10630-02.dwg; May 4, 2020 - 7:31 PM; C:\WINDOWS\SYS\CD\MOFFATT AND NICHOL

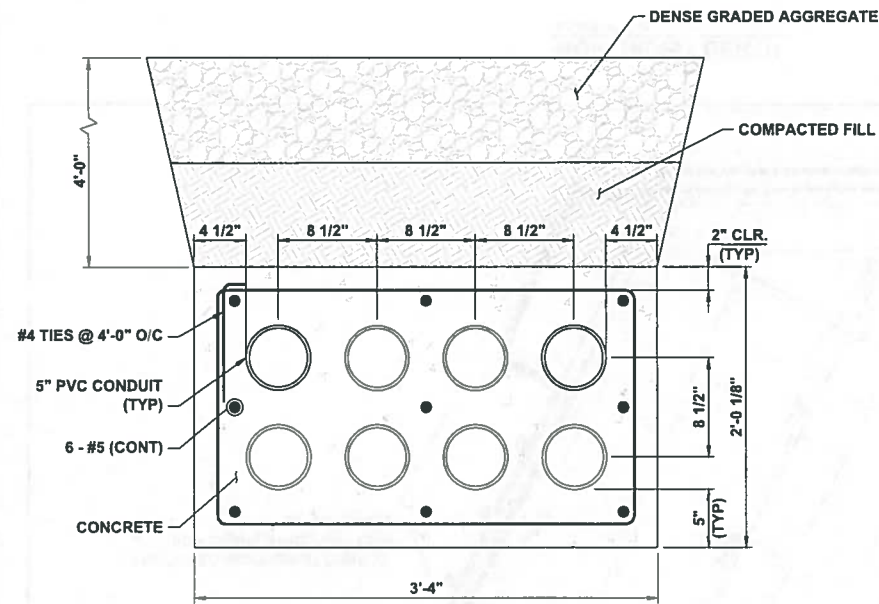

TYPICAL 5" 8-WAY CONCRETE ENCASED DUCTBANK
SCALE: 1 1/2"=1'-0"

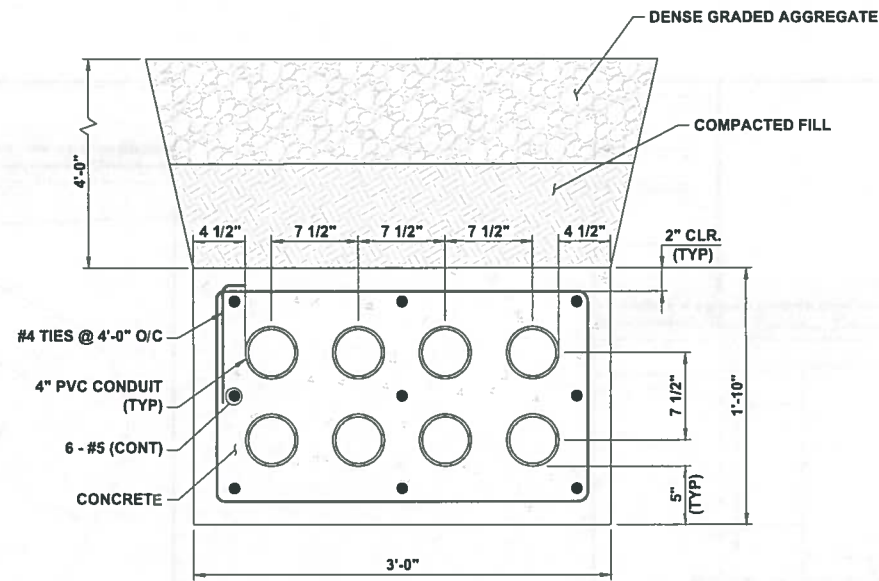

TYPICAL 4" 8-WAY CONCRETE ENCASED DUCTBANK
SCALE: 1 1/2"=1'-0"

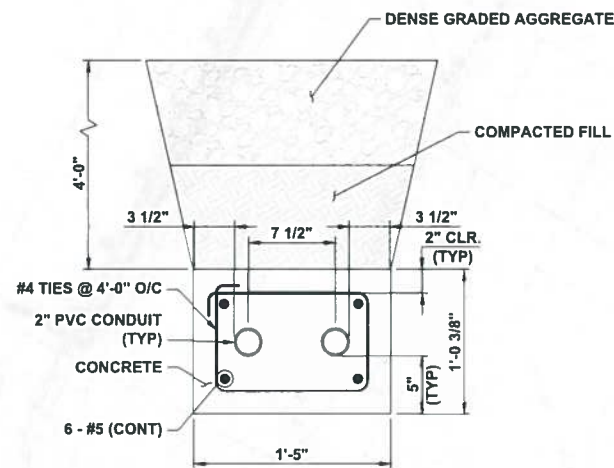

TYPICAL 2" 2-WAY CONCRETE ENCASED DUCTBANK
SCALE: 1 1/2"=1'-0"

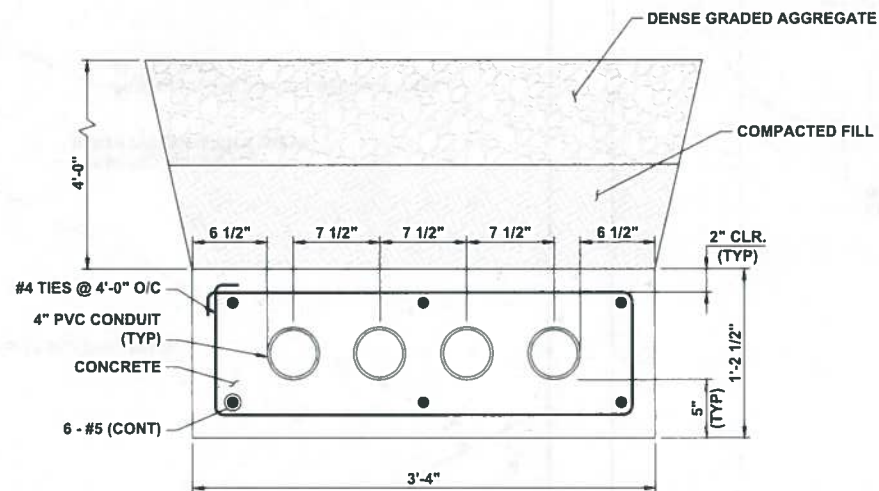

TYPICAL 2" & 4" 4-WAY CONCRETE ENCASED DUCTBANK
SCALE: 1 1/2"=1'-0"

DUCTBANK NOTES:

1. ALL 5" SCHEDULE 40 PVC CONDUIT SHALL HAVE AN OUTER DIAMETER OF NO MORE THAN 5.5" AND THE ENDBELL OUTER DIAMETER OF NO MORE THAN 6.1".
2. ALL 4" SCHEDULE 40 PVC CONDUIT SHALL HAVE AN OUTER DIAMETER OF NO MORE THAN 4.5" AND THE ENDBELL OUTER DIAMETER OF NO MORE THAN 5".
3. ALL END BELLES SHALL BE STAGGERED AT NO LESS THAN 12" ACROSS THE ENTIRE DUCTBANK SECTION.
4. ALL DUCTBANK SPACINGS SHALL BE REDUCED TO ENTER THE OPENINGS IN THE EQUIPMENT.
5. THE TOP OF THE DUCTBANK SHALL NOT BE SHALLOWER THAN 48" BELOW FINISHED GRADE.
6. DEVIATIONS IN DUCTBANK SHALL BE REQUIRED FOR ROUTING AROUND UTILITIES AND OTHER DUCTBANKS.
7. THE SLOPE OF ALL DUCTBANKS SHALL BE TOWARDS MANHOLES. IN DUCTBANK LENGTHS THAT DO NOT HAVE MANHOLES, THE SLOPE SHALL BE TO THE EQUIPMENT NEAREST TO THE EDGE OF THE PIER.
8. CONCRETE COMPRESSIVE STRENGTH $f_c = 3,000$ PSI.
9. REINFORCING STEEL - UNCOATED ASTM A615, GRADE 60.
10. CONTINUOUS REINFORCING STEEL SHALL BE LAPPED 36 X BAR DIAMETER AT SPLICES AND CORNERS, UNLESS OTHERWISE NOTED.
11. INTENTIONALLY LEFT BLANK
12. THE SPACING IN BETWEEN 4", 5" AND 2" MIXED CONDUITS IN A SINGLE DUCTBANK SHALL MAINTAIN THE OVERALL CENTERLINE OF THE LARGEST CONDUIT IN THE DUCTBANK SECTION. THIS REQUIRES 7-1/2" IN BETWEEN 2" AND 4" CONDUITS, AND 8-1/2" IN BETWEEN A 4" AND 5" CONDUIT. THE REBAR AND CONCRETE COVER OF THE DUCTBANK CONDUITS SHALL REMAIN AS INDICATED FOR THE LARGEST CONDUIT IN THE DUCTBANK RUN.



PERMITTING SET
ISSUED: 10/23/2020
NOT TO BE USED FOR CONSTRUCTION



DUCTBANK DETAILS
STATE PIER INFRASTRUCTURE IMPROVEMENTS
STATE PIER FACILITY - NEW LONDON, CT



Digitally signed by
Eric D Smith
DN: c=US,
o=Unaffiliated,
ou=A01410C000001
71CC9B22C1000095
D6, cn=Eric D Smith
Date: 2020.10.27
11:21:29 -04'00'

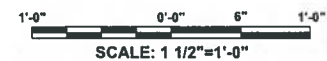

DWG: NFO_0180SP\Project\10530 Detail Design State pier\030 CAD\DWG\Permit\Set\10530-33.dwg, October 15, 2020 - 4:47 PM, MMBRANDA (C), MOFFATT AND NICHOL

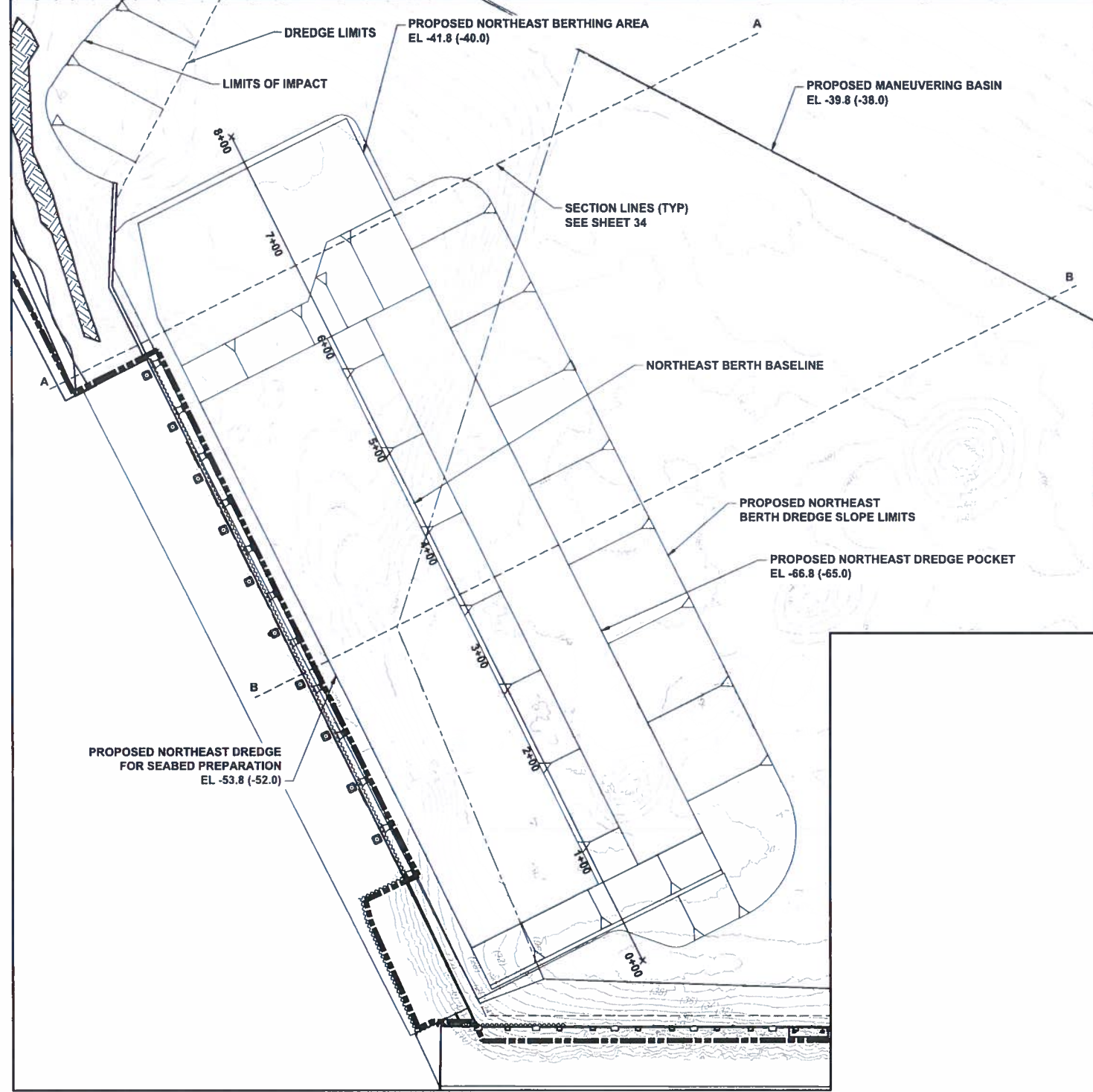

NORTHEAST BERTH
SCALE: 1" = 60'

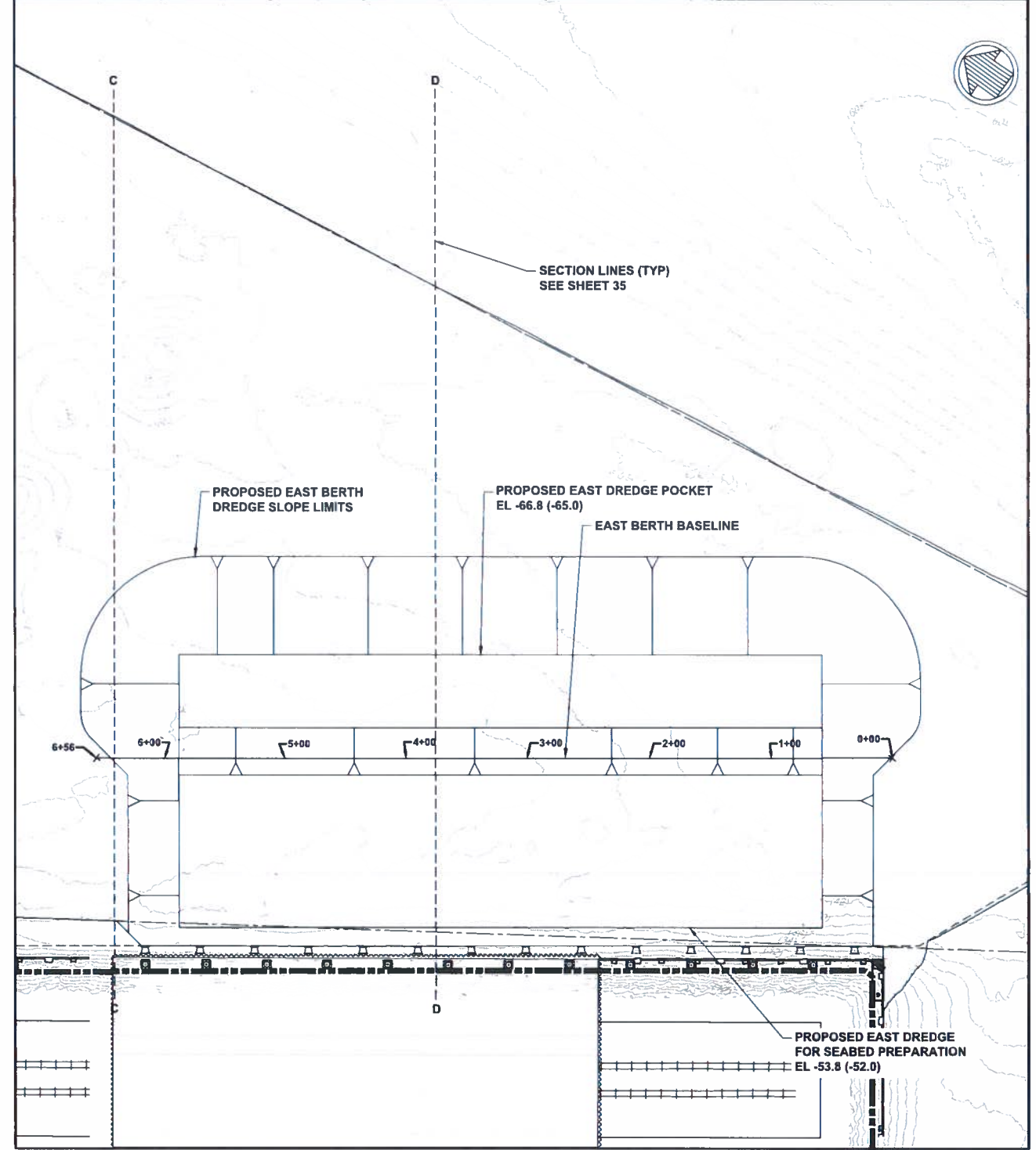

EAST BERTH
SCALE: 1" = 60'

NOTES:
1. ELEVATIONS SHOWN ARE IN NAVD88 DATUM WITH MLLW IN PARENTHESES



PERMITTING SET
ISSUED: 10/23/2020
NOT TO BE USED FOR CONSTRUCTION



PROPOSED DREDGE ALIGNMENT PLAN
STATE PIER INFRASTRUCTURE IMPROVEMENTS
STATE PIER FACILITY - NEW LONDON, CT

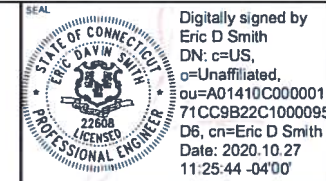

Digitally signed by Eric D Smith
DN: c=US, o=Unaffiliated, ou=A01410C00000171CC9B22C1000095, D6, cn=Eric D Smith
Date: 2020.10.27 11:25:44 -04'00'



SCALE: 1" = 60'

DWG INFO: C:\BOS\Projects\10630\Detail Design\State Pier\500\CADD\Asv\PermitSet\10630-34.dwg; October 13, 2020 - 12:41 PM; MMIRANDA; © MOFFATT AND NICHOL

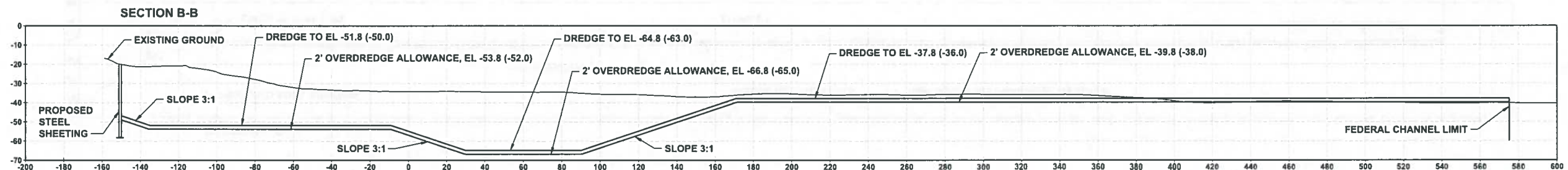
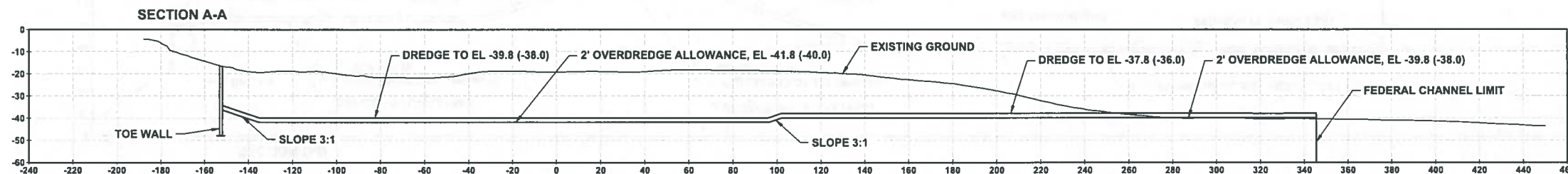

NOTE:
 1. ELEVATIONS SHOWN ARE IN NAVD88 DATUM WITH MLLW IN PARENTHESES



PERMITTING SET
 ISSUED: 10/23/2020
 NOT TO BE USED FOR CONSTRUCTION



NORTHEAST BERTH DREDGE SECTIONS
 STATE PIER INFRASTRUCTURE IMPROVEMENTS
 STATE PIER FACILITY - NEW LONDON, CT

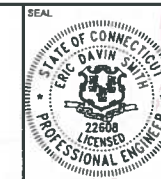

Digitally signed by
 Eric D Smith
 DN: c=US,
 o=Unaffiliated,
 ou=A01410C000001
 71CC9B22C1000095
 D6, cn=Eric D Smith
 Date: 2020.10.27
 11:31:56 -04'00'

DWG INFO: C:\BOS\Projects\16353\Detail Design\State Pier\16353-35.dwg, October 13, 2020 12:50 PM, MARRANDIA, (C) MOFFATT AND NICHOL

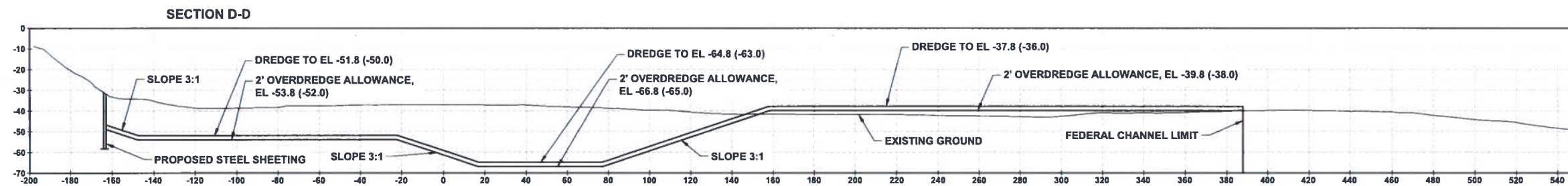
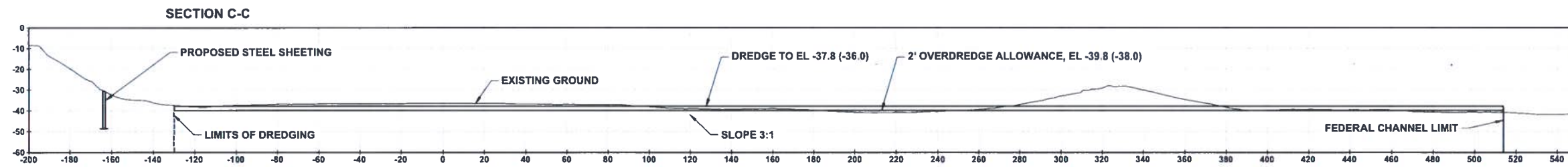

NOTE:
1. ELEVATIONS SHOWN ARE IN NAVD88 DATUM WITH MLLW IN PARENTHESES



PERMITTING SET
ISSUED: 10/23/2020
NOT TO BE USED FOR CONSTRUCTION



EAST BERTH DREDGE SECTIONS
STATE PIER INFRASTRUCTURE IMPROVEMENTS
STATE PIER FACILITY - NEW LONDON, CT

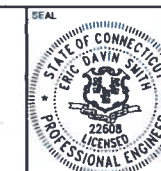

Digitally signed by
Eric D Smith
DN: c=US,
o=Unaffiliated,
ou=A01410C000001
71CC9B22C1000095
D6, cn=Eric D Smith
Date: 2020.10.27
11:35:42 -04'00'

DWG INFO: O:\BOS\Projects\10630_Dredge\State_Pier\500 CAD\DWG\PermitSet\10630-36.dwg, October 11, 2020 - 12:49 PM, MARRANDA, C] MOFFATT AND NICHOL

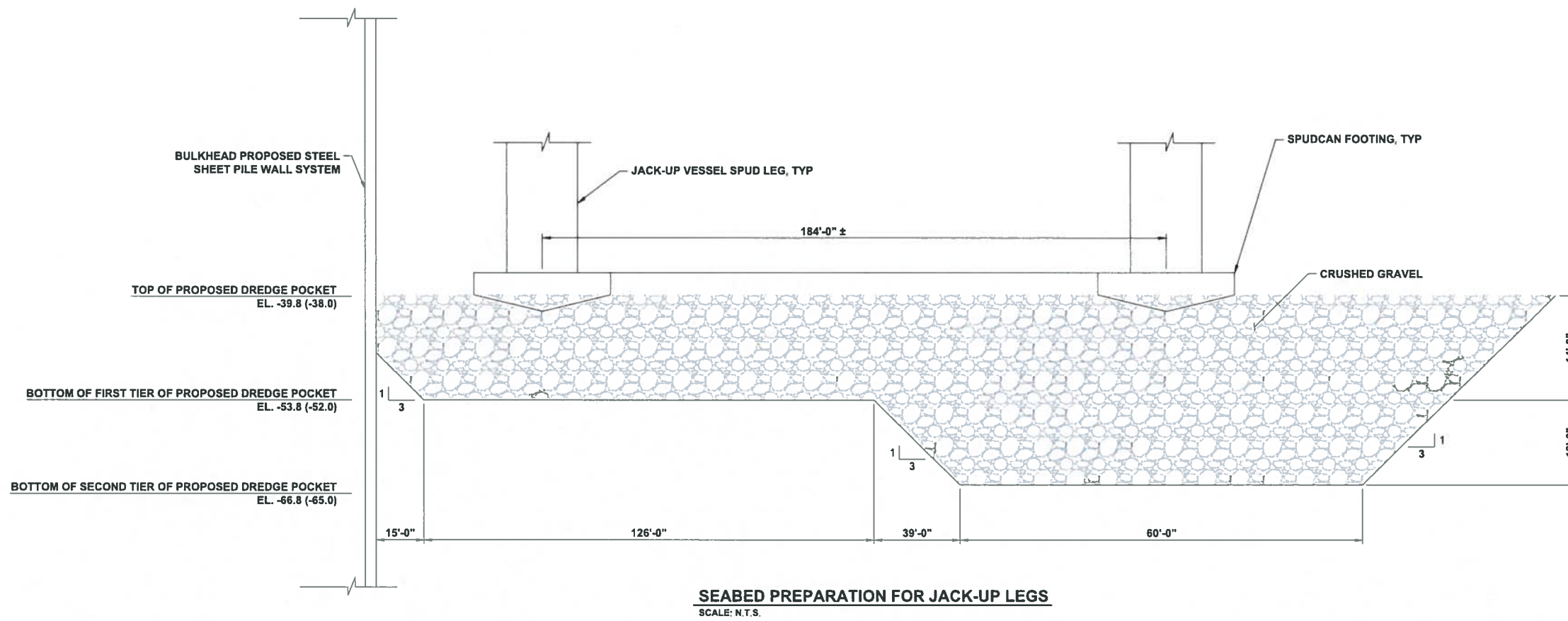

SEABED PREPARATION FOR JACK-UP LEGS
SCALE: N.T.S.

NOTES:

1. ELEVATIONS SHOWN ARE IN NAVD88 DATUM WITH MLLW IN PARENTHESES
2. SPUD LEG AND FOOTING ARE REPRESENTATIVE. ACTUAL SIZES OF THESE ELEMENTS ARE DEPENDENT ON THE SELECTED INSTALLATION VESSEL.
3. NORTHEAST BERTH CRUSHED GRAVEL= 99,400 CY
4. EAST BERTH CRUSHED GRAVEL = 99,400 CY



PERMITTING SET
ISSUED: 10/23/2020
NOT TO BE USED FOR CONSTRUCTION



DREDGE SECTIONS FOR INSTALL VESSEL JACK-UP LEGS
STATE PIER INFRASTRUCTURE IMPROVEMENTS
STATE PIER FACILITY - NEW LONDON, CT

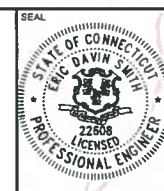

Digitally signed by
Eric D Smith
DN: c=US,
o=Unaffiliated,
ou=A01410C000001
71CC9B22C1000095
D6, cn=Eric D Smith
Date: 2020.10.27
11:40:13 -04'00'



Compliance Certification Form

The following certification must be signed by the licensee working in consultation with a Connecticut-licensed design professional and must be submitted to the address indicated at the end of this form within ninety (90) days of completion of the authorized work.

1. Licensee Name: _____ DEEP License Number(s): _____ Municipality in which project is occurring: _____	
2. Check one: (a) <input type="checkbox"/> "I certify that the final site conditions and / or structures are in general conformance with the approved site plans". Identify and describe any deviations and attach to this form. (b) <input type="checkbox"/> "The final site conditions and / or structures are not in general conformance with the approved site plans. The enclosed "as-built" plans note the modifications".	
3. "I understand that any false statement in this certification is punishable as a criminal offence under section 53a-157b of the General Statutes and under any other applicable law."	
_____ Signature of Licensee	_____ Date
_____ Name of Licensee (print or type)	
_____ Signature of CT-Licensed Design Professional	_____ Date
_____ Name of CT-Licensed Design Professional (print or type)	
_____ Professional License Number (if applicable)	Affix Stamp Here <div style="border: 1px solid black; width: 100px; height: 100px; display: inline-block; vertical-align: middle;"></div>
<ul style="list-style-type: none"> As-built plans shall include: elevations or tidal datums, as applicable, and structures, including any proposed elevation views and cross sections included in the approved license plans. Such as-built plans shall be the original ones and be signed and sealed by an engineer, surveyor or architect, as applicable, who is licensed in the State of Connecticut. The Licensee will be notified by staff of the Land and Water Resources Division (LWRD) if further compliance review is necessary. Lack of response by LWRD staff does not imply compliance. 	
Submit this completed form to : Regulatory Section Department of Energy and Environmental Protection Land & Water Resources Division 79 Elm Street Hartford, CT 06106-5127	